

Aluminum Frames

Handbook

ถูกรกว่าสินค้าที่คุณใช้อยู่
ลองเทียบ! ส่งเร็ว พร้อมตัด



ราคาถูกกว่าสินค้าทั่วไปในตลาดสูงสุดถึง 30%

NEW! รุ่น N-series ตอบโจทย์คุณมากขึ้น

- ✓ รุ่นประหยัด! ราคาถูกกว่าสินค้าทั่วไปในตลาดสูงสุดถึง 30%
- ✓ N-series 4 โมเดล สามารถเลือกความยาวได้ตามต้องการ พร้อมจัดส่ง
- ✓ จัดส่งได้รวดเร็วภายใน 2 วัน

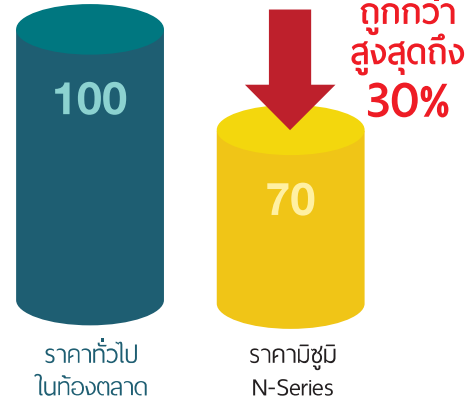

*ตัวอย่างราคาเฉลี่ยบางรุ่นจากการสำรวจของมิซูมิ

Aluminum Frame ของเราส่งภายใน 2 วัน

Days to Ship



Days
to Ship

2 Days

*สั่งสินค้าก่อน 12.30 u.

- ตัวอย่างการส่งสินค้า 2 วันทำการ หากได้รับคำสั่งซื้อในวันจันทร์ ลูกค้าจะได้รับสินค้าในวันพฤหัสบดี

MON	TUE	WED	THU	FRI	SAT
0	1	2	Customer receive product*		
Your Order Day		Ship Out Day			

*วันที่ลูกค้าได้รับของขึ้นอยู่กับพื้นที่จัดส่งของลูกค้า

**จำนวนวันจัดส่งอาจมีการเปลี่ยนแปลง หากมีการสั่งทำพิเศษ (Alteration)

MISUMI Aluminum Frame

มิซูมิแค็ตตาล็อกจะบอกข้อมูลทางเทคนิคต่างๆ ของอลูมิเนียมในระบบ JIS

Aluminum Frame ของมิซูมิ แบ่งเป็นทั้งหมด 4 ซีรีส์

- 20,25 mm (ซีรีส์ 5)
- 30 mm (ซีรีส์ 6)
- 40 mm (ซีรีส์ 8)
- 45, 50 mm (ซีรีส์ 8-45)

การแบ่งแต่ละซีรีส์จะถูกกำหนดตามพื้นที่หน้าตัดของอลูมิเนียม และร่อง slot ตรงกลางของ Aluminum Frame (ตามภาพด้านล่าง)

Detail of Slot

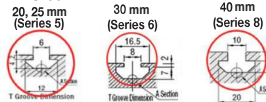

Slot Bottom Details (Enlarge View of A)

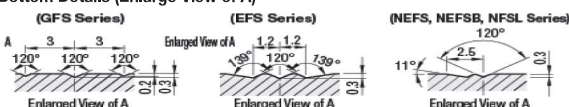

โดยที่ความแตกต่างของร่อง slot ในแต่ละซีรีส์ของมิซูมิ ก็ขึ้นอยู่กับการออกแบบ และการเลือกใช้งานของผู้ใช้เอง โดยพื้นฐานหลักๆ ของการเลือกคือ

1. น้ำหนักของการรับภาระของอลูมิเนียมในงานนั้นๆ
2. ข้อจำกัดของขนาดของพื้นที่ที่จะนำไปติดตั้ง
3. รูปทรงเมื่อทำการประกอบแล้วดูสมส่วน มั่นคง และดูแข็งแรง
4. สามารถใช้งานภายใต้สภาพแวดล้อมทั้งที่มีความชื้น มีอุณหภูมิหลากหลาย และมีความเป็นกรดเป็นด่างได้ในระดับหนึ่ง

จากการเก็บข้อมูลของปริมาณการสั่งซื้อ Aluminum Frame ของลูกค้าในไทย ทำให้รู้ถึงความต้องการ จึงทำให้เกิดการจัดหา Aluminum Frame ด้วยความมุ่งมั่นที่จะรองรับความต้องการของกลุ่มลูกค้าที่ใช้บริการของมิซูมิอยู่แล้ว และลูกค้ากลุ่มใหม่ในอนาคต แต่ในการจัดหาวัตถุดิบและการผลิตนี้ ลูกค้าไม่ต้องกังวลเรื่องคุณภาพ

เพราะทุกขั้นตอน ทางมิซูมิได้มีการตรวจสอบและควบคุมให้อยู่ในมาตรฐาน JIS Standard โดยจำนวนซีรีส์ที่ทำการผลิตและเก็บสต็อก จะสามารถตรวจสอบได้จากแค็ตตาล็อก และเจ้าหน้าที่ฝ่าย Technical Support หรือจากข้อมูลที่รวบรวมมานำเสนอต่อลูกค้า (ข้อมูลในหน้า 4)

SELECTION METHODS

■ Selecting Aluminum Frame Models

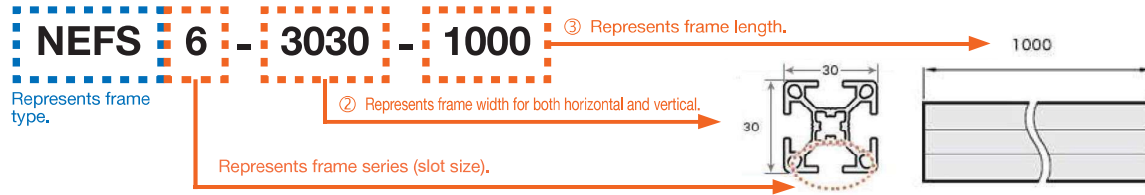

Selecting Brackets & Nuts

Bracket.....HBLFSN 6

Please select the same number as the series (frame slot size) (①).

Nut.....HNTT ^A6-^B6

A Please select the same number as the series (frame slot size) (①).

B Please select thread size (M Diameter).

◆ About Selecting the Accessories Parts

At the time of the selection of the aluminum frame, it determines the series of available peripheral parts. Please select peripheral parts, based on the series.

(ex.) When manufacturing with aluminum frame NEFS6-3030 of NEFS6 Series

Brackets	Blind Bracket, Blind Joint	Nuts	Extrusion End Caps	Chassis Supplies	Door Parts	Other type of accessories
HBLFSN6 HBLTS6 etc.	HBLBS6 HSJ6 etc.	HNTT6-Tap Hole Diameter HNTAT6-Tap Hole Diameter etc.	HFC6-3030-Color HSCA6-Color etc.	HAJPS6 HCFT6-60 etc.	HHPSN6 HMGN6 etc.	HFCC6 LCSA6-Color etc.

Both NEFS8 Series and NEFS8-45 Series have a great number of mountable parts.

Pre-Assembly Nut HNTT8-8

▶ Mountable with NEFS8 Series
Mountable with NEFS8-45 Series

Full Cover HSCA8-S

▶ Mountable with NEFS8 Series
Mountable with NEFS8-45 Series

The structure made with aluminum frame can be mounted with various peripheral parts, depending on application.

Selecting Alteration for Aluminum Frame

MISUMI Aluminum Frame products can be utilized for structure building with highly enhanced design flexibility when available alteration options are applied. Some alterations are not applicable depending on Frame types and sizes. Check for the available alterations in Table of Alterations (page 4).

Alteration Example

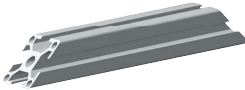
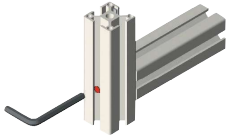
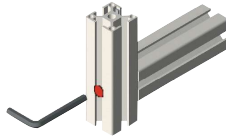
Type	Alterations	Alteration Codes	App. Example	Contents
End Tapping	End Tapping (Center Hole)	LTP/RTP/TPW		Add a tapped hole to the extrusion.
Cutting Method Change	45-Degree Cut	LCT45/RCT45		Cut at 45 degrees.
Drill Wrench Hole	Wrench Hole in Specified Position	AH/BH/CH/DH/EH AV/BV/CV/DV/EV AP/BP/CP/DP/EP		Add a wrench hole at any position of the end (left).
Counterboring	Counterbores in Specified Position	XA/XB/XC/XD/XE YA/YB/YC/YD/YE		Add a counterbore at any position of the end (left).

◆ End Tapping (Center Hole)

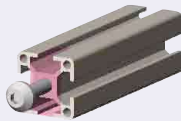

Left Side
LTP

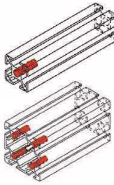

Right Side
RTP

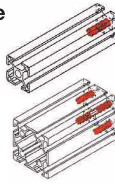

Both Sides
TPW

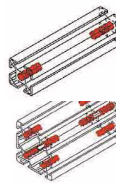

The number of tap varies depending on the frame type (the number of hole for tapping in the end). For specifying tapping hole dia. and depth of this alteration, check in Table of Alterations on P.4

◆ 45-Degree Cut

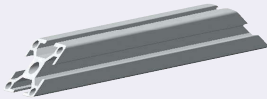

45-Degree Cut LCT45 : Adds a 45 degree cut on the left end in the specified direction.
RCT45 : Adds a 45 degree cut on the right end in the specified direction.

Cut with cross the section facing up

Left



LCT45

Right



RCT45

*In case of angled cut, it is impossible to specify other alterations in the same direction.

◆ Counterbores in Specified Position

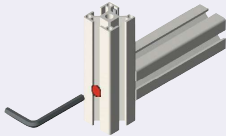

Top to Bottom (Vertical)
XA XB XC XD XE

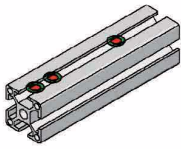

Right to Left (Horizontal)
YA YB YC YD YE

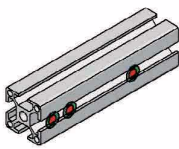

Cross Section View

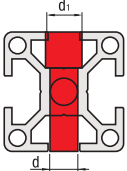

*Counterbore is added on every slot for multiple slotted extrusions.

◆ Wrench Hole in Specified Position

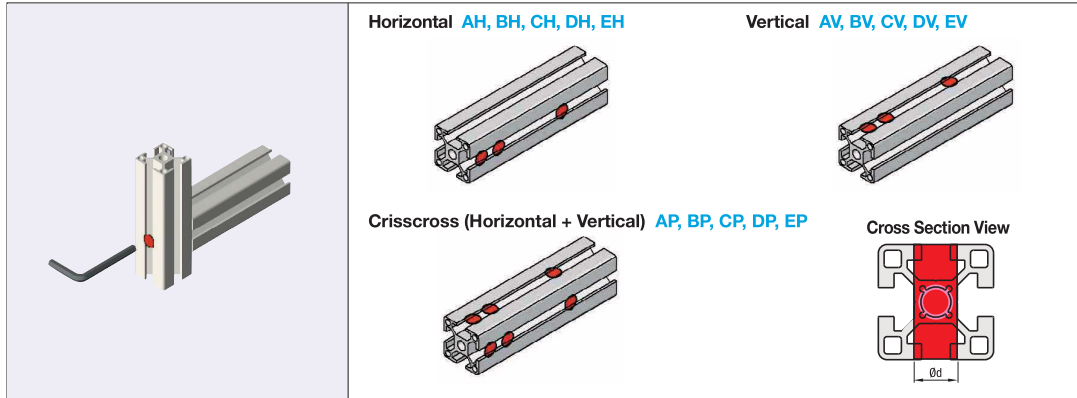

Alteration Code Specification Method

Alteration Code specified in 0.5mm increments (from Left End)	Frame Series	Ød
AH, BH, CH, DH, EH (Horizontal) AV, BV, CV, DV, EV (Vertical) AP, BP, CP, DP, EP (Crisscross)	20, 25 mm Series	7.35
	30 mm Series	5,8
	40 mm Series	8
	45, 50 Series	

* Wrench Hole d dim. can be selected for 30 mm Series. Specify with X5 or X8

* Up to 5 locations in Vertical, Horizontal, and Crisscross directions can be specified.

Alteration Code Example

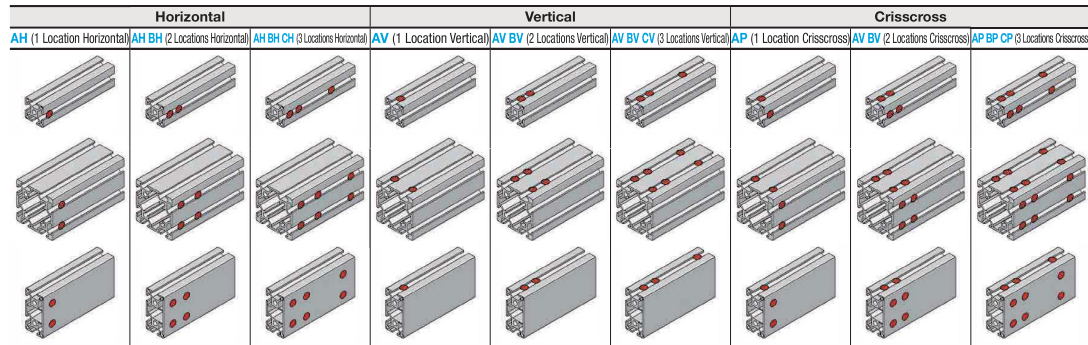

When ordering, select Part Number and Alteration



Ordering Example

Part Number
NEFS6-3030

L
500

Alteration
LTP

◆ Table of Alterations

Alterations		Tapping			Extrusion Cutting		Counterbore			∅8 Wrench Hole						
		End Tapping			45-Degree Cut		in Specified Position			in Specified Position						
		Shape of Tapped Hole	Left	Right	Left/Right	Left	Right	Counterbore	From Top to Bottom	From Right to Left	Horizontal	Vertical	Horizontal & Vertical			
LTP	RTP		TPW	LCT45	RCT45	XA-XE	YA-YE		AH-EH	AV-EV	AP-EP					
Product Model	Model 1	Model 2														
NFS5 NFSB5	2020	M5 Depth 15	○	○	○	○	25 d 5.5 d1 9.5	○	○	○	○	○				
	2040		○	○	○	○		○	○	○	○	○				
	2060		○	○	○	○		○	○	○	○	○	○			
	2080		○	○	○	○		○	○	○	○	○	○			
	2525	M8 Depth 24	○	○	○	○		26 d 6.5 d1 11	○	○	○	○	○			
	2550		○	○	○	○			○	○	○	○	○			
	4040		○	○	○	○			○	○	○	○	○	○		
	4060		○	○	○	○			○	○	○	○	○	○		
4080	M5 Depth 15	○	○	○	○	26 d 6.5 d1 11	○		○	○	○	○				
2020		○	○	○	○		○		○	○	○	○				
2040		○	○	○	○		○		○	○	○	○	○			
4040		○	○	○	○		○		○	○	○	○	○			
NFS75	2020	M5 Depth 15	○	○	○		○	26 d 6.5 d1 11	○	○	○	○	○			
NFSR5	2020		○	○	○		○		○	○	○	○	○			
NFS6 NFSB6 NFSB6	3030		M8 Depth 24	○	○		○		○	26 d 6.5 d1 11	○	○	○	○	○	
	3060			○	○		○		○		○	○	○	○	○	
	3090	○		○	○	○	○		○		○	○	○			
	30120	○		○	○	○	○		○		○	○	○			
	5050	○		○	○	○	○		○		○	○	○			
	50100	○		○	○	○	○		○		○	○	○			
	6060	○		○	○	○	○	○	○		○	○				
	6090	○		○	○	○	○	○	○		○	○				
	60120	○		○	○	○	○	○	○		○	○				
	100100	○		○	○	○	○	○	○		○	○				
	606030	○		○	○	○	○	○	○		○	○				
	NFSF6	3030		M8 Depth 24	○	○	○	○	28 d 9 d1 14		○	○	○	○	○	
NEFS6	3060	○	○		○	○	○	○		○	○	○				
6060	○	○	○		○	○	○	○		○	○					
NEFST6	3030	○	○		○	○	○	○		○	○	○				
3060	○	○	○		○	○	○	○		○	○					
NFSL6	3030	○	○		○	○	○	○		○	○	○				
3060	○	○	○		○	○	○	○		○	○					
GNFS6	3030	○	○		○	○	○	○		○	○	○				
3060	○	○	○		○	○	○	○		○	○					
NFSR6	3030	○	○		○	○	○	○		○	○	○				
3060	○	○	○		○	○	○	○		○	○					
NEFS8 NFSB8	4040	M12 Depth 36	○		○	○	○	26 d 6.5 d1 11		○	○	○	○	○		
	4080		○	○	○	○	○		○	○	○					
	40120		○	○	○	○	○		○	○	○					
	40160		○	○	○	○	○		○	○	○					
	8080	M8 Depth 24	○	○	○	○	28 d 9 d1 14		○	○	○	○	○			
	80160		○	○	○	○			○	○	○	○				
	808040		○	○	○	○			○	○	○	○				
	NEFSF8		4040	○	○	○			○	○	○	○	○			
	4080	○	○	○	○	○			○	○	○					
	NEFST8	4040	○	○	○	○			○	○	○	○				
	NFSL8	4040	M12 Depth 36	○	○	○			○	28 d 9 d1 14	○	○	○	○	○	
	4080	○		○	○	○			○		○	○	○			
GNFS8	4040	○		○	○	○		○	○		○	○				
4080	○	○		○	○	○		○	○		○					
NFSR8	4040	M12 Depth 36	○	○	○	○		26 d 6.5 d1 11	○		○	○	○	○		
808040	○		○	○	○	○			○		○	○				
NFS8 NFSB8 NFSB8	4545		M12 Depth 36 (∅12.5 Threaded Insert)	○	○	○	○		28 d 9 d1 14		○	○	○	○	○	
	4590			○	○	○	○				○	○	○			
	5050	○		○	○	○	○				○	○				
	50100	○		○	○	○	○				○	○				
	6060	M8 Depth 24	○	○	○	○	26 d 6.5 d1 11				○	○	○	○	○	
	9090		○	○	○	○					○	○	○			
	100100		○	○	○	○				○	○	○				
	909045		○	○	○	○				○	○	○				
	NEFSF8	4545	M12 Depth 36 (∅12.5 Threaded Insert)	○	○	○				○	28 d 9 d1 14	○	○	○	○	○
	NEFST8	4545		○	○	○				○		○	○	○		
	NFSL8	4545		○	○	○		○		○		○	○			
	4590	○		○	○	○		○		○		○				
GNFS8	4545	M12 Depth 36	○	○	○	○		26 d 6.5 d1 11	○	○		○	○	○		
	4590		○	○	○	○			○	○		○				
	5050		○	○	○	○			○	○		○				
	50100		○	○	○	○			○	○		○				
	6060	M8 Depth 24	○	○	○	○	28 d 9 d1 14		○	○		○	○	○		
	9090		○	○	○	○			○	○		○				
	100100		○	○	○	○			○	○		○				
	100200		○	○	○	○			○	○		○				
NFSR8	4545	M12 Depth 36	○	○	○	○			26 d 6.5 d1 11	○	○	○	○	○		
4545	○		○	○	○	○				○	○					
4545	○		○	○	○	○				○	○					
4545	○		○	○	○	○				○	○					

⚠ When performing multiple alterations simultaneously, specify alteration codes consecutively.

HOW TO DESIGN

How to Design Step 1 ~ 4

STEP 1
Deciding the production type

When making a housing for mounting the device on a box-shape

STEP 2
Outer shape configuration

(ex.) Width: 1500, Depth: 1000, Height: 800mm

Shape and Size *Create punch image

STEP 3
Frame configuration

Select a loaded bearing frame.

*Refer to the technical data page for load calculation.

Click on WEB: Technical information

STEP 4
Attachment method configuration

Bracket attachment

Step 5 ~ Completing

STEP 5
Creating a unit diagram

(ex.) Width: 1500, Depth: 1000, Height: 800mm, Frame: NEFS8-4040

Draws frame width and overlaps

STEP 6
Part list expansion

Frame + Length	QTY.
NEFS8-4040-1500	2
NEFS8-4040-1420	2
NEFS8-4040-920	6
NEFS8-4040-760	4
NEFS8-4040-720	2

Bracket	QTY.
HBLFSN8	44

Nut	QTY.
HNTT8-8	88

Bolt	QTY.
CBM8-20	88

Completed

Completed with a product of parts spreadsheet and a wrench

ALUMINUM FRAME INDEX

**20,25
mm**

(Series 5)

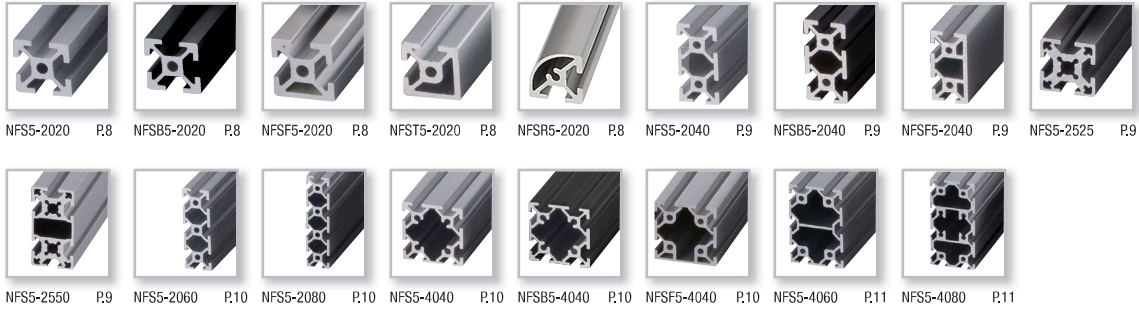

**30
mm**

(Series 6)



**40
mm**

(Series 8)

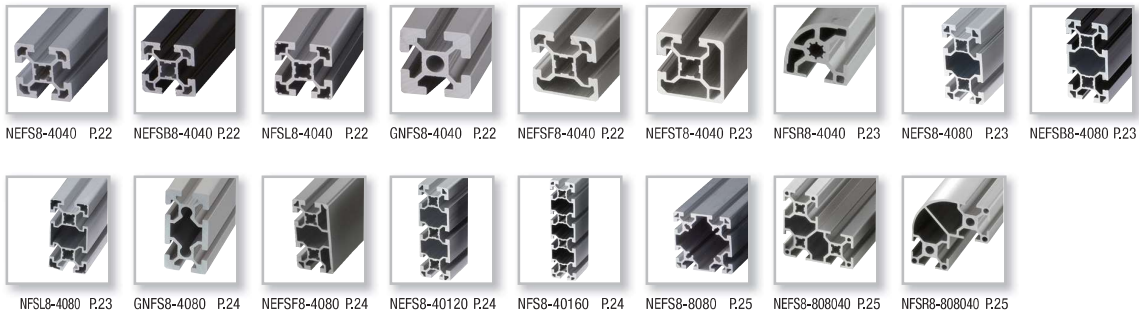

**45,50
mm**

(Series 8-45)



ALUMINUM ACCESSORIES INDEX



Tabbed Reversal Brackets (1 Slot) P.12



Tabbed Reversal Brackets (2 Slots) P.12



One - Side Rib Brackets P.12



Thick Brackets (1 Slot and 2 Slots) P.12



Thick Brackets (3 Slots) and Ultra Thick Brackets P.12



Post - Assembly Insertion Nuts and Spring Nuts P.13



Post - Assembly Insertion Stopper Nuts and Insertion Nuts with Leaf Springs P.13

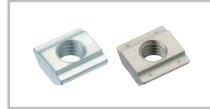

Pre - Assembly Insertion Nuts P.13



Pre - Assembly Insertion Spring Nuts and Short Nuts P.13



Extrusion End Caps P.13



Tabbed Reversal Brackets (1 Slot) P.20



Tabbed Reversal Brackets (2 Slots) P.20



One - Side Rib Brackets P.20



Thick Brackets (1 Slot and 2 Slots) P.20



Thick Brackets (3 Slots) and Ultra Thick Brackets P.20



Post - Assembly Insertion Nuts and Spring Nuts P.21



Post - Assembly Insertion Stopper Nuts and Insertion Nuts with Leaf Springs P.21



Pre - Assembly Insertion Nuts P.21



Pre - Assembly Insertion Spring Nuts and Short Nuts P.21



Extrusion End Caps P.21



Tabbed Reversal Brackets (1 Slot) P.26



Thick Brackets (1 Slot and 2 Slots) P.26



One - Side Rib Brackets P.26



Thin Brackets P.26



Ultra Thick Brackets (2 Slots and 3 Slots) P.26



Post - Assembly Insertion Nuts and Spring Nuts P.27



Post - Assembly Insertion Stopper Nuts and Insertion Nuts with Leaf Springs P.27



Pre - Assembly Insertion Nuts P.27



Pre - Assembly Insertion Spring Nuts and Short Nuts P.27

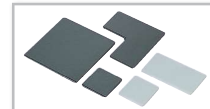

Extrusion End Caps P.27

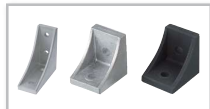

Tabbed Reversal Brackets (1 Slot) P.34



Tabbed Reversal Brackets (2 Slots) P.34



Thick Brackets (1 Slot and 2 Slots) P.34



Thin Brackets P.34



Ultra Thick Brackets (2 Slots) P.34



Post - Assembly Insertion Nuts and Spring Nuts P.35



Post - Assembly Insertion Stopper Nuts and Insertion Nuts with Leaf Springs P.35



Pre - Assembly Insertion Nuts P.35

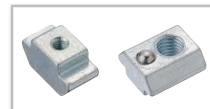

Pre - Assembly Insertion Spring Nuts and Short Nuts P.35

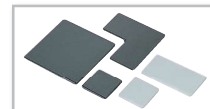

Extrusion End Caps P.35

20,25 mm (Series 5)

ALUMINUM FRAME

Slot Width 6: Series 20, 25 for small coverings,
small part racks...

When ordering, select Part Number and Values from Selection Steps ①-③.



Ordering
Example

① Part Number - ② L
NFS5-2020 - 800

Square shape 4-Side Slots



NFS5-2020
Clear Anodize



NFSB5-2020
Black Anodize

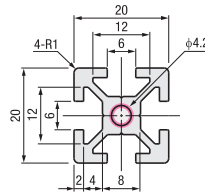

Material	Length	Weight	Section Area	Cross Sectional Moment of Inertia
A6063S-T5	50-4000mm	0.50kg/m	183mm ²	$I_x 0.742 \times 10^4 \text{mm}^4$ $I_y 0.742 \times 10^4 \text{mm}^4$

Square shape 3-Side Slots



NFSF5-2020
Clear Anodize

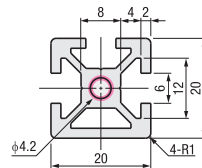

Material	Length	Weight	Section Area	Cross Sectional Moment of Inertia
A6063S-T5	50-4000mm	0.53kg/m	195mm ²	$I_x 0.834 \times 10^4 \text{mm}^4$ $I_y 0.834 \times 10^4 \text{mm}^4$

Square shape 2-Side Slots



NFST5-2020
Clear Anodize

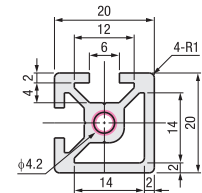

Material	Length	Weight	Section Area	Cross Sectional Moment of Inertia
A6063S-T5	50-4000mm	0.53kg/m	196mm ²	$I_x 0.808 \times 10^4 \text{mm}^4$ $I_y 0.808 \times 10^4 \text{mm}^4$

R Shape



NFSR5-2020
Clear Anodize

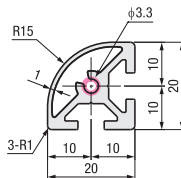

Material	Length	Weight	Section Area	Cross Sectional Moment of Inertia
A6063S-T5	50-4000mm	0.42kg/m	153mm ²	$I_x 0.57 \times 10^4 \text{mm}^4$ $I_y 0.57 \times 10^4 \text{mm}^4$

Aluminum Frames Connection Method

Connection Method	Bracket Connection	Blind Joint Connection
Connection Examples		
Characteristics	The standard and economical connection method. Cover plates can be mounted by adding taps on the brackets.	A connection method that produces clean corners. Suitable for sections where equipment is loaded and unloaded or doors are to be mounted. However, alterations are needed on the frames and usable frames are limited. See the product pages for compatible frames.
Standard Model	HBLFSM6, HBLTS6, etc.	HCJ6, HMJ6, etc.

Connection Method	Blind Brackets	Bolts Connection
Connection Examples		
Characteristics	Brackets are hidden inside of slots producing clean corners. Alteration is not required. However, allowable load is smaller than that of bracket connections.	Connections only with bolts can be achieved by applying tapping and counterbore alterations on the frames.
Standard Model	HBLBS6, HABLBS6, etc.	-

Application Examples of Aluminum Frame

Fences

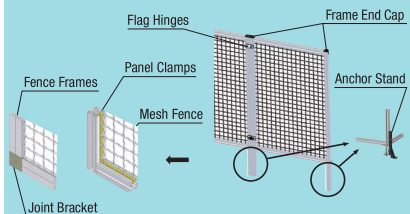

20,25 mm (Series 5)

ALUMINUM FRAME

Slot Width 6: Series 20, 25 for small coverings,
small part racks...

When ordering, select Part Number and Values from Selection Steps ①-③.



Ordering
Example

① Part Number
NFS5-2040

③ L
800

Rectangle shape 4-Side Slots

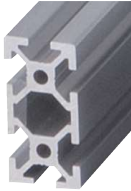

NFS5-2040
Clear Anodize



NFSB5-2040
Black Anodize

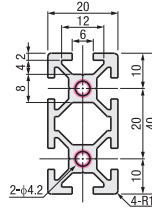

Material	Length	Weight	Section Area	Cross Sectional Moment of Inertia	
A6063S-T5	50~4000mm	0.88kg/m	324mm ²	I _x 1.358×10 ⁴ mm ⁴	I _y 5.13×10 ⁴ mm ⁴

Rectangle shape 3-Side Slots



NFSF5-2040
Clear Anodize

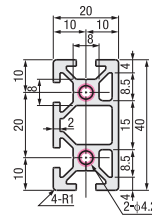

Material	Length	Weight	Section Area	Cross Sectional Moment of Inertia	
A6063S-T5	50~4000mm	0.93kg/m	344mm ²	I _x 1.52×10 ⁴ mm ⁴	I _y 5.4×10 ⁴ mm ⁴

Square shape 4-Side Slots



NFS5-2525
Clear Anodize

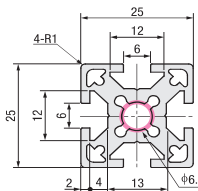

Material	Length	Weight	Section Area	Cross Sectional Moment of Inertia	
A6063S-T5	50~4000mm	0.81kg/m	320mm ²	I _x 1.71×10 ⁴ mm ⁴	I _y 1.71×10 ⁴ mm ⁴

Rectangle shape 4-Side Slots



NFS5-2550
Clear Anodize

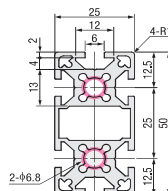

Material	Length	Weight	Section Area	Cross Sectional Moment of Inertia	
A6063S-T5	50~4000mm	1.36kg/m	503mm ²	I _x 2.97×10 ⁴ mm ⁴	I _y 12.74×10 ⁴ mm ⁴

Equipment Covers

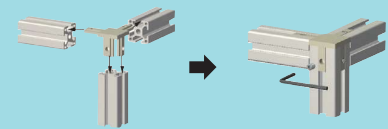
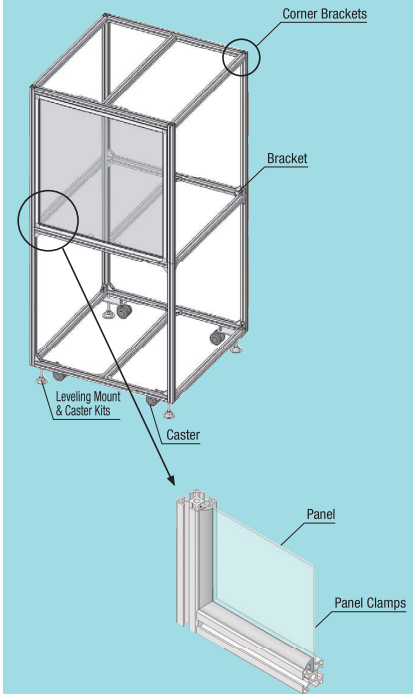

The position of 3 frames are easily aligned.

They function as frame end caps.

Transfer Rails

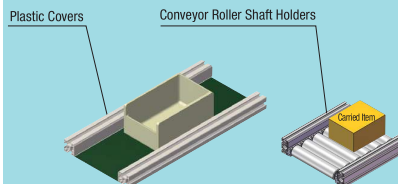
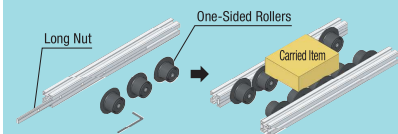

20,25 mm

(Series 5)

ALUMINUM FRAME

Slot Width 6: Series 20, 25 for small coverings, small part racks...

When ordering, select Part Number and Values from Selection Steps ①~③.



Ordering Example

①② Part Number - ③ L
 NFS5-2060 - 1000

Rectangle shape 4-Side Slots



NFS5-2060
Clear Anodize

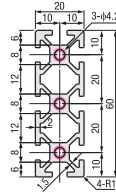

Material	Length	Weight	Section Area	Cross Sectional Moment of Inertia	
A6063S-T5	50-4000mm	1.26kg/m	464mm ²	I _x 1.97×10 ⁴ mm ⁴	I _y 15.98×10 ⁴ mm ⁴

Rectangle shape 4-Side Slots



NFS5-2080
Clear Anodize

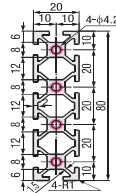

Material	Length	Weight	Section Area	Cross Sectional Moment of Inertia	
A6063S-T5	50-4000mm	1.64kg/m	605mm ²	I _x 2.56×10 ⁴ mm ⁴	I _y 36×10 ⁴ mm ⁴

Square shape 4-Side Slots



NFS5-4040
Clear Anodize



NFSB5-4040
Black Anodize

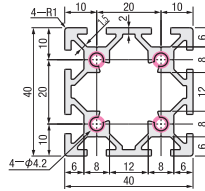

Material	Length	Weight	Section Area	Cross Sectional Moment of Inertia	
A6063S-T5	50-4000mm	1.28kg/m	472mm ²	I _x 8.89×10 ⁴ mm ⁴	I _y 8.89×10 ⁴ mm ⁴

Square shape 3-Side Slots



NFSF5-4040
Clear Anodize

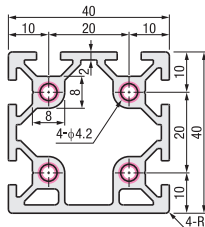

Material	Length	Weight	Section Area	Cross Sectional Moment of Inertia	
A6063S-T5	50-4000mm	1.41kg/m	522mm ²	I _x 9.78×10 ⁴ mm ⁴	I _y 9.32×10 ⁴ mm ⁴

2-B: For an equipment covering enclosure

(2-B-1) Determining Outer Perimeter Configuration
Width, depth, and height determined base on the equipment to be mounted.

(2-B-2) Selection of Connection Methods
See (2-A-2) on left page for the connection methods. Bracket connections for the panels, and Single Joint connections are selected for this example.

(2-B-3) Creation of Unit Drawing
(Ex.) Width: 2000 Depth: 1500 Height: 2000mm
Frame: NEFS6-3030

Shape and Size

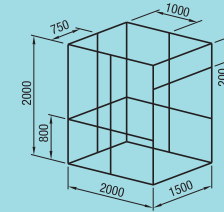

Draw Frame Width and Overlapping

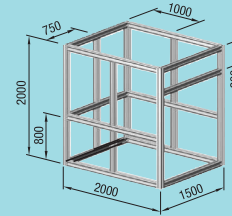

Determine the connection method.

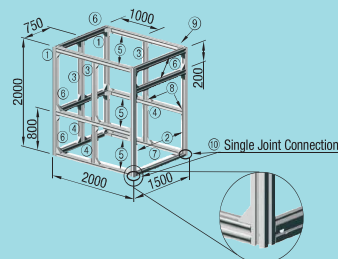
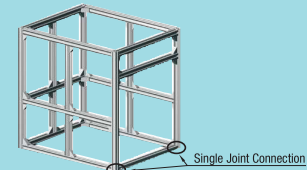

Complete with cover plates (provided separately) mounted.

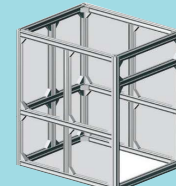

20,25 mm (Series 5)

ALUMINUM FRAME

Slot Width 6: Series 20, 25 for small coverings,
small part racks...

When ordering, select Part Number and Values from Selection Steps ①-③.



Ordering
Example

① Part Number
NFS5-4060

③ L
- 1000

Rectangle shape 4-Side Slots



NFS5-4060
Clear Anodize

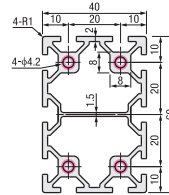

Material	Length	Weight	Section Area	Cross Sectional Moment of Inertia	
A6063S-T5	50~4000mm	1.80kg/m	665mm ²	I _x 12.63×10 ⁴ mm ⁴	I _y 27×10 ⁴ mm ⁴

Rectangle shape 4-Side Slots



NFS5-4080
Clear Anodize

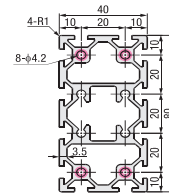

Material	Length	Weight	Section Area	Cross Sectional Moment of Inertia	
A6063S-T5	50~4000mm	2.69kg/m	994mm ²	I _x 18.29×10 ⁴ mm ⁴	I _y 63.3×10 ⁴ mm ⁴

(2-B-4) Components Expanded

	Frame	Length	Quantity
①	NEFS6-3030-2000		2
②	NEFS6-3030-2000-LCH		2
③	NEFS6-3030-1170		3
④	NEFS6-3030-740		3
⑤	NEFS6-3030-1940		6
⑥	NEFS6-3030-1440		5
⑦	NEFS6-3030-1440-RDH-LDH		1
	Brackets, Bolts, Nuts		Quantity
⑧	NBLFSN6-C-SET	4x13=52	
⑨	NBLFSN6-SET		10
⑩	NSJ6		2

(Description)

- ② Add a wrench access hole on one end for Single Joint connections.
- ⑦ Add a D Hole to each end for Joint Nuts.
- ⑧ Add tapped holes on brackets for panels. Also include the screw/nut sets.
In this example, a panel is mounted to the side shown in the figure below. (Surfaces except front right and bottom)
- ⑨ Top, bottom, and middle section brackets include bolt/nut sets.
- ⑩ Single Joint Kits need with the extrusion on ⑦ and ②.

■ Hole Machining Details (D Hole, S Hole, M Hole)

Machining direction of D, S, M holes differs depending on the frame shape and the number of slots.

(Note 1) For the D hole and M hole, the max. hole machining length is 90mm.

(Note 2) For the frames with L-shaped cross section, D, S, M hole machining is not available.

For 4-Side Slot Frames

(Ex.: NEFS6-3030, NEFS6-3060)

(D holes, S holes, M holes)

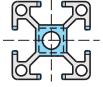

(D holes, S holes, M holes)

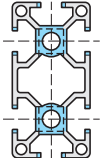

For the square-shaped cross section

- The D, S, M holes can be drilled vertically or horizontally.
- If any type of hole machining is not performed in combination with other types of hole machining, it is not necessary to distinguish between vertical drilling and horizontal drilling.

For the rectangle-shaped cross section

- The D, S, M holes can be drilled vertically or horizontally.
- Place the frame in such a way that the longitudinal sides are vertically stood.

For Smooth Sided Frames

(Ex.: NEFSF6-3030, NEFST6-3030)

①

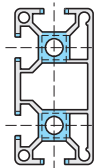

②

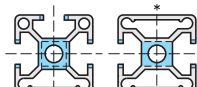

③

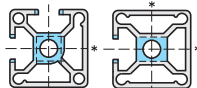

* D holes must not be machined on the surfaces marked with this asterisk.

- For 2-Side/3-Side Slot frames, the D, M holes can be machined vertically or horizontally. Holes are not machined on flat surfaces.
- When using the Single Joints HSJD for 2-side slot or 3-side slot, this hole machining will be performed.
- M holes go through.
- Place each type of frame in the same manner as indicated below.
 - ① On the vertical length.
 - ② Flat side down.
 - ③ One flat side down and another flat side right.
- Any S hole cannot be machined toward the smooth surfaces.
- If the cross section is rectangle-shaped, place the frame in such a way that the longitudinal sides are vertically stood.

NEFS6-3030-500-LDH

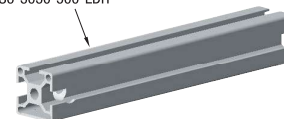

Place the frame in such a way that the smooth surface is on the bottom side. For the frame with rectangle-shaped cross section, however, ensure that the longitudinal sides are vertically stood.

20,25 mm

(Series 5)

ACCESSORIES FOR ALUMINUM FRAME BRACKETS/NUTS/EXTRUSION END CAPS

■ Brackets

Tabbed Reversal Brackets (For 1 Slot)

HBLFNS5

HBLFSNB5

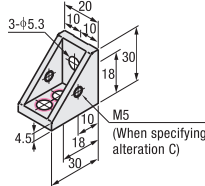

Part Number	Material	Surface Treatment
HBLFNS5	ADC12	-
HBLFSNB5	ADC12	Black Anodize

Tabbed Reversal Brackets (For 2 Slots)

HBLFSDW5

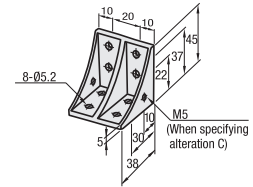

Part Number	Material	Surface Treatment
HBLFSDW5	ADC12	-

Tabbed Reversal Brackets (For 1 Slot)

HBLFSSW5

HBLFSSWB5

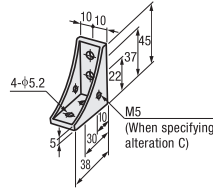

Part Number	Material	Surface Treatment
HBLFSSW5	ADC12	-
HBLFSSWB5	ADC12	Black Anodize

Tabbed Reversal Brackets (For 2 Slots)

HBLFSD5

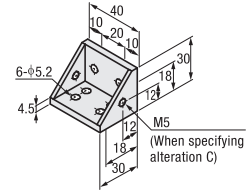

Part Number	Material	Surface Treatment
HBLFSD5	ADC12	-

One-Side Rib Brackets (For 1 Slot)

HBLFSL5

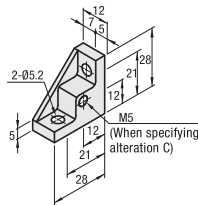

Part Number	Material	Surface Treatment
HBLFSL5	ADC12	-

Thick Brackets (For 2 Slots)

HBLTD5

HBLTDB5

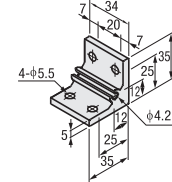

Part Number	Material	Surface Treatment
HBLTD5	A6N01SS-T5	Clear Anodize
HBLTDB5	A6N01SS-T5	Black Anodize

Thick Brackets (For 1 Slot)

HBLTS5

HBLTSB5

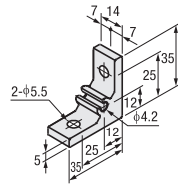

Part Number	Material	Surface Treatment
HBLTS5	A6N01SS-T5	Clear Anodize
HBLTSB5	A6N01SS-T5	Black Anodize

Ultra Thick Brackets (For 2 Slots)

HBLUD5

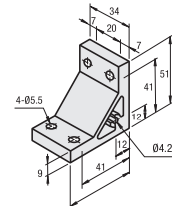

Part Number	Material	Surface Treatment
HBLUD5	A6N01SS-T5	Clear Anodize

Thick Brackets (For 1 Slot)

HBLSS5

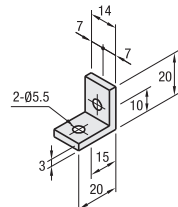

Part Number	Material	Surface Treatment
HBLSS5	A6N01SS-T5	Clear Anodize

Thick Brackets (For 3 Slots)

HBLTT5

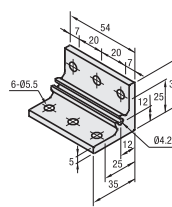

Part Number	Material	Surface Treatment
HBLTT5	A6N01SS-T5	Clear Anodize

Nuts

Post-Assembly Insertion Nuts

HNTF5

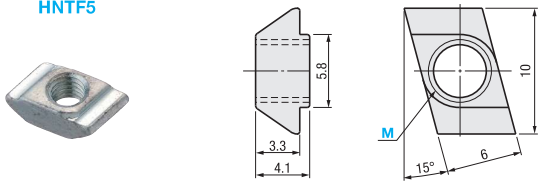

Part Number	M	Material	Surface Treatment
HNTF5	3 4	S10C Equivalent	Trivalent Chromate

Post-Assembly Insertion Spring Nuts

HNTP5

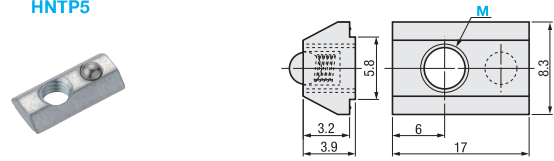

Part Number	M	Material			Surface Treatment
		Main Body	Ball	Spring	
HNTP5	3 4 5	S10C Equivalent	SUS304	SWP-A	Trivalent Chromate

Post-Assembly Insertion Stopper Nuts

HNTA5

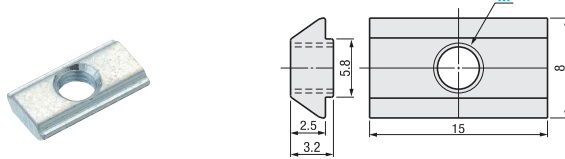

Part Number	M	Material	Surface Treatment
HNTA5	3 4 5	S10C Equivalent	Trivalent Chromate

Post-Assembly Insertion Nuts with Leaf Springs

HNTAP5

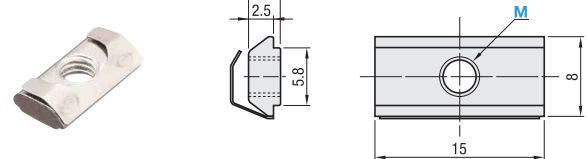

Part Number	M	Material	Surface Treatment
HNTAP5	3 4 5	S10C Equivalent	Trivalent Chromate

Pre-Assembly Insertion Nuts

HNTT5

HNTTSN5

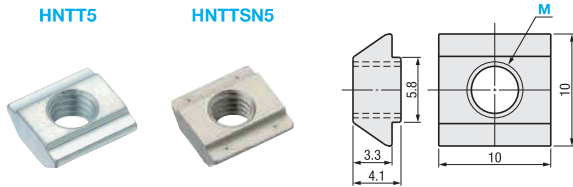

Part Number	M	Material	Surface Treatment
HNTT5	3 4 5	S10C Equivalent	Trivalent Chromate
HNTTSN5	3 4 5	SUS316 Equivalent	-

Pre-Assembly Insertion Spring Nuts

HNTU5

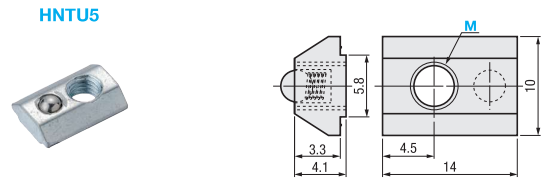

Part Number	M	Material			Surface Treatment
		Main Body	Ball	Spring	
HNTU5	3 4 5	S10C Equivalent	SUS304	SWP-A	Trivalent Chromate

Pre-Assembly Insertion Short Nuts

HNTJ5

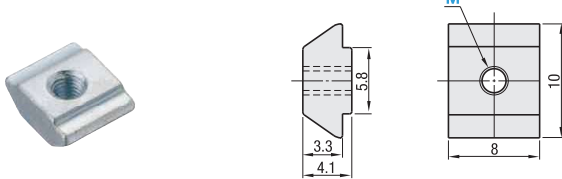

Part Number	M	Material	Surface Treatment
HNTJ5	3 4 5	S10C Equivalent	-

EX Example

Built-in spring prevents slips. Moves easily in the slot when pressed slightly by hand.

*Does not fall even if the extrusion is placed vertically.

Ordering Example

Part Number	-	M
HNTA5	-	4

Extrusion End Caps



Part Number	Color	Material
HFC5-2020	B (Black), S (Light Gray)	Polyamide
HFC5-2525		
HFC5-2040		
HFC5-2550		
HFC5-2060		
HFC5-4040		
HFC5-4060		

HFC5-2020

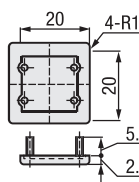

HFC5-2525

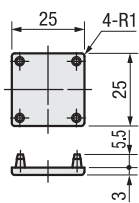

HFC5-2040

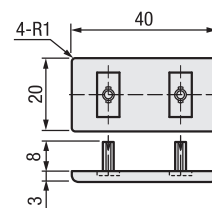

HFC5-2550

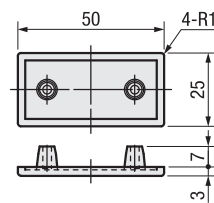

HFC5-2060

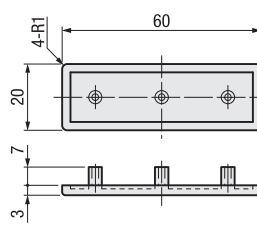

HFC5-4040

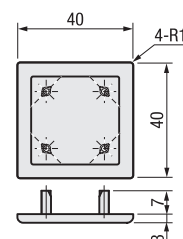

HFC5-4060

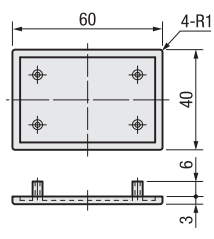

<Supplementary Information>

· Add -B (Black) / -S (Light Gray) to the end of the part number to specify the color.
Example) HFC5-2020-B



Example



Ordering Example

Part Number	-	Color
HFC5-2020	-	B

30 mm

(Series 6)

ALUMINUM FRAME

Slot Width 8: Series 30 for medium coverings, conveyor frames...

When ordering, select Part Number and Values from Selection Steps ①-③.



Ordering Example

① Part Number
NEFS6-3030

-

② L
800

Square shape 4-Side Slots



NEFS6-3030
Clear Anodize

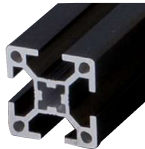

NEFSB6-3030
Black Anodize

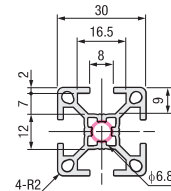

Material	Length	Weight	Section Area	Cross Sectional Moment of Inertia	
A6063S-T5	50-4000mm	0.80kg/m	296mm ²	$I_x 2.85 \times 10^4 \text{mm}^4$	$I_y 2.85 \times 10^4 \text{mm}^4$

Square shape 4-Side Slots, Light Weight



NFSL6-3030
Clear Anodize

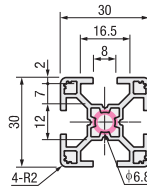

Material	Length	Weight	Section Area	Cross Sectional Moment of Inertia	
A6063S-T5	50-4000mm	0.76kg/m	280mm ²	$I_x 2.68 \times 10^4 \text{mm}^4$	$I_y 2.68 \times 10^4 \text{mm}^4$

Square shape 4-Side Slots, High Rigidity

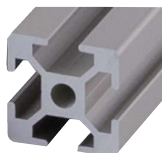

GNFS6-3030
Clear Anodize

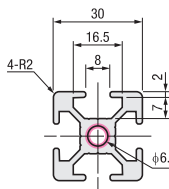

Material	Length	Weight	Section Area	Cross Sectional Moment of Inertia	
A6063S-T6	50-4000mm	1.02kg/m	377mm ²	$I_x 3.47 \times 10^4 \text{mm}^4$	$I_y 3.47 \times 10^4 \text{mm}^4$

Square shape 3-Side Slots

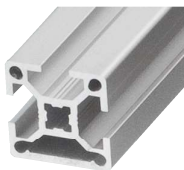

NEFSF6-3030
Clear Anodize

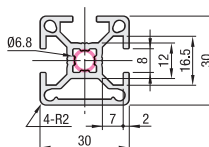

Material	Length	Weight	Section Area	Cross Sectional Moment of Inertia	
A6063S-T5	50-4000mm	0.86kg/m	320mm ²	$I_x 3.06 \times 10^4 \text{mm}^4$	$I_y 2.80 \times 10^4 \text{mm}^4$

Example of Frame Connection

Connection with Thick Bracket

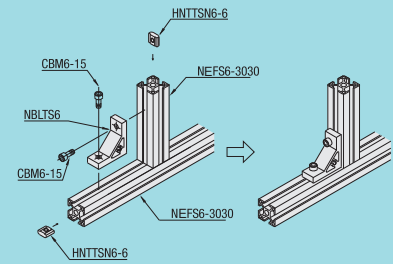

Blind Bracket Connections

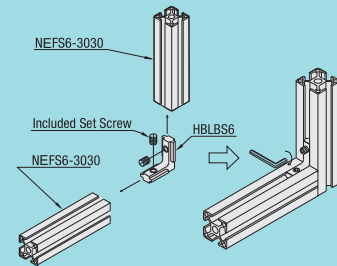
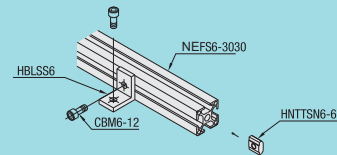
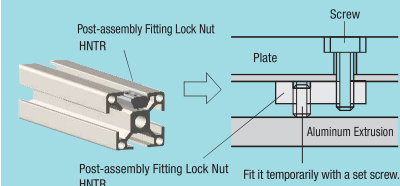

Plate on Frame Mounting

Thin Bracket Connections



Post Assy. Ins. Locknut Connections



30 mm

(Series 6)

ALUMINUM FRAME

Slot Width 8: Series 30 for medium coverings, conveyor frames...

When ordering, select Part Number and Values from Selection Steps ❶-❸.



Ordering Example

❶ Part Number

NEFST6-3030

❷ L

800

Square shape 2-Side Slots



NEFST6-3030
Clear Anodize

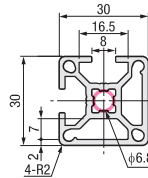

Material	Length	Weight	Section Area	Cross Sectional Moment of Inertia	
A6063S-T5	50~4000mm	0.91kg/m	337mm ²	$I_x 3.08 \times 10^4 \text{mm}^4$	$I_y 3.08 \times 10^4 \text{mm}^4$

R shape



NFSR6-3030
Clear Anodize

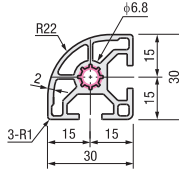

Material	Length	Weight	Section Area	Cross Sectional Moment of Inertia	
A6063S-T5	50~4000mm	0.82kg/m	306mm ²	$I_x 2.42 \times 10^4 \text{mm}^4$	$I_y 2.42 \times 10^4 \text{mm}^4$

Rectangle shape 4-Side Slots

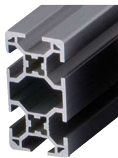

NEFS6-3060
Clear Anodize



NEFSB6-3060
Black Anodize

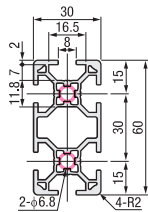

Material	Length	Weight	Section Area	Cross Sectional Moment of Inertia	
A6063S-T5	50~4000mm	1.44kg/m	535mm ²	$I_x 5.49 \times 10^4 \text{mm}^4$	$I_y 20.6 \times 10^4 \text{mm}^4$

Rectangle shape 4-Side Slots, Light Weight



NFSL6-3060
Clear Anodize

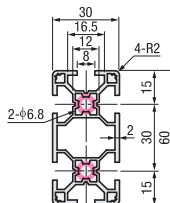

Material	Length	Weight	Section Area	Cross Sectional Moment of Inertia	
A6063S-T5	50~4000mm	1.29kg/m	476mm ²	$I_x 4.87 \times 10^4 \text{mm}^4$	$I_y 17.87 \times 10^4 \text{mm}^4$

Example of Use: 45° Angle Brackets

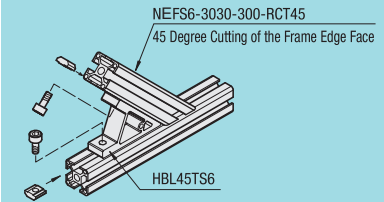

Example of Cover Mounting on the Bracket

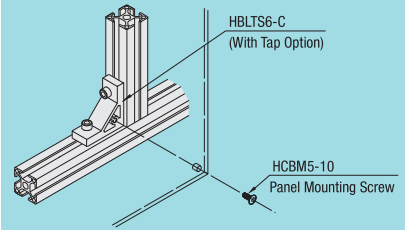

Connecting Unequal Sized Frames with Flag Hinges

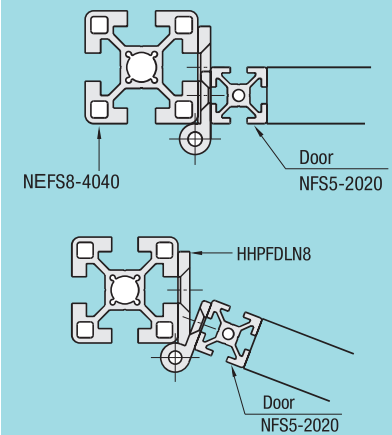

30 mm

(Series 6)

ALUMINUM FRAME

Slot Width 8: Series 30 for medium coverings, conveyor frames...

When ordering, select Part Number and Values from Selection Steps ①-③.



Ordering Example

①② Part Number - ③ L
GNFS6-3060 - 500

Rectangle shape 4-Side Slots, High Rigidity



GNFS6-3060
Clear Anodize

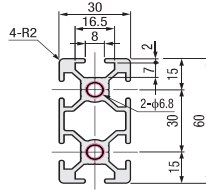

Material	Length	Weight	Section Area	Cross Sectional Moment of Inertia	
A6063S-T6	50-4000mm	1.71kg/m	364mm ²	I _x 5.95×10 ⁴ mm ⁴	I _y 23.78×10 ⁴ mm ⁴

Rectangle shape 3-Side Slots

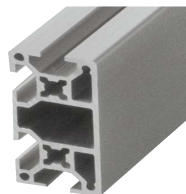

NEFSF6-3060
Clear Anodize

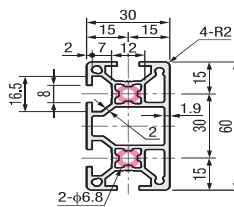

Material	Length	Weight	Section Area	Cross Sectional Moment of Inertia	
A6063S-T5	50-4000mm	1.54kg/m	573mm ²	I _x 5.97×10 ⁴ mm ⁴	I _y 21.1×10 ⁴ mm ⁴

Rectangle shape 2-Side Slots



NEFST6-3060
Clear Anodize

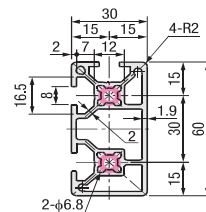

Material	Length	Weight	Section Area	Cross Sectional Moment of Inertia	
A6063S-T5	50-4000mm	1.53kg/m	567mm ²	I _x 5.83×10 ⁴ mm ⁴	I _y 21.19×10 ⁴ mm ⁴

Rectangle shape 4-Side Slots



NEFS6-3090
Clear Anodize

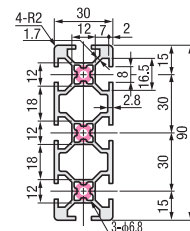

Material	Length	Weight	Section Area	Cross Sectional Moment of Inertia	
A6063S-T5	50-4000mm	2.24kg/m	831mm ²	I _x 8.80×10 ⁴ mm ⁴	I _y 69.05×10 ⁴ mm ⁴

How to Use: Thin Brackets

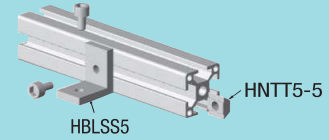

How to Use: Corner Blind Brackets

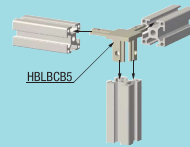

The position of 3 frames are easily aligned.

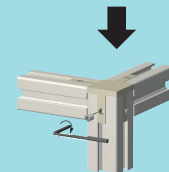

They function as frame end caps.

How to Use: Angled Brackets

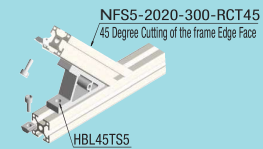

How to Use: Free Angle Brackets

① Connection of Two End Sections

The method of connection two end sections of extrusions is to add taps to the extrusions. Either HBLTBA20 or HBLTBBN20 can be used for connection.

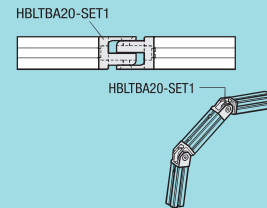

② Connection of Two Frame Side Faces (HBLTBA20 Connection)

Anti-spin protrusion is shown in the right figure.

Connect two frame sides to side with HBLTBA20, screws and nuts.

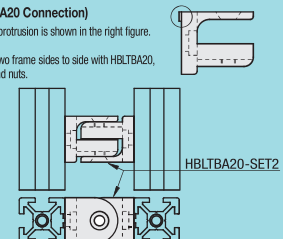

30 mm

(Series 6)

ALUMINUM FRAME

Slot Width 8: Series 30 for medium coverings, conveyor frames...

When ordering, select Part Number and Values from Selection Steps ①-③.



Ordering Example

① Part Number

NEFS6-30120

- ③ L

- 500

Rectangle shape 4-Side Slots



NEFS6-30120
Clear Anodize

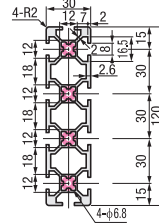

Material	Length	Weight	Section Area	Cross Sectional Moment of Inertia
A6063S-T5	50~4000mm	3.01kg/m	1116mm ²	$I_x 11.48 \times 10^4 \text{mm}^4$ $I_y 157.62 \times 10^4 \text{mm}^4$

Sqaure shape 4-Side Slots



NFS6-5050
Clear Anodize

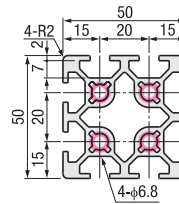

Material	Length	Weight	Section Area	Cross Sectional Moment of Inertia
A6063S-T5	50~4000mm	2.32kg/m	857mm ²	$I_x 21.60 \times 10^4 \text{mm}^4$ $I_y 21.60 \times 10^4 \text{mm}^4$

Rectangle shape 4-Side Slots



NFS6-50100
Clear Anodize

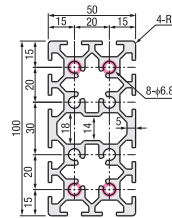

Material	Length	Weight	Section Area	Cross Sectional Moment of Inertia
A6063S-T5	50~4000mm	4.36kg/m	1614mm ²	$I_x 42.40 \times 10^4 \text{mm}^4$ $I_y 153.5 \times 10^4 \text{mm}^4$

Sqaure shape 4-Side Slots

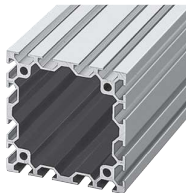

NFS6-100100
Clear Anodize

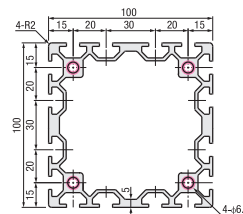

Material	Length	Weight	Section Area	Cross Sectional Moment of Inertia
A6063S-T5	50~4000mm	5.52kg/m	2043mm ²	$I_x 265.2 \times 10^4 \text{mm}^4$ $I_y 265.2 \times 10^4 \text{mm}^4$

How to Use Post-Assembly Insertion Blind Brackets

- ① Fit the post-assembly insertion BB body in the slot of the frame.

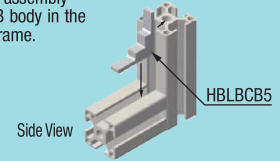

- ② Tilt two pieces of post-assembly insertion nuts and fit them in both ends of post-assembly insertion BB body.

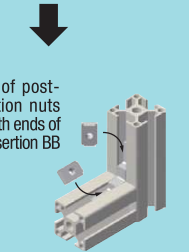
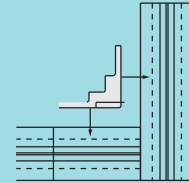

- ③ Fix post-assembly insertion BB body and post-assembly insertion BB nuts with set screws.

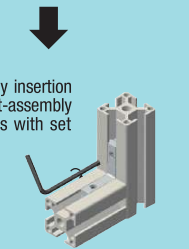
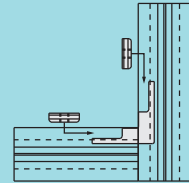

30 mm

(Series 6)

ALUMINUM FRAME

Slot Width 8: Series 30 for medium coverings, conveyor frames...

When ordering, select Part Number and Values from Selection Steps ①-③.



Ordering Example
 ① Part Number - ② L
 NFSB6-6060 - 1000

Square shape 4-Side Slots



NFS6-6060
Clear Anodize



NFSB6-6060
Black Anodize

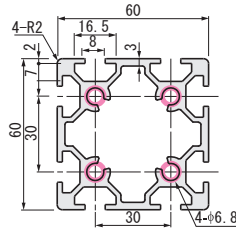

Material	Length	Weight	Section Area	Cross Sectional Moment of Inertia	
A6063S-T5	50-4000mm	2.63kg/m	971mm ²	I _x 41.4×10 ⁴ mm ⁴	I _y 41.4×10 ⁴ mm ⁴

Rectangle shape 4-Side Slots



NEFS6-6090
Clear Anodize

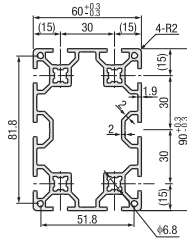

Material	Length	Weight	Section Area	Cross Sectional Moment of Inertia	
A6063S-T5	50-4000mm	3.10kg/m	1147mm ²	I _x 52.6×10 ⁴ mm ⁴	I _y 111.0×10 ⁴ mm ⁴

Rectangle shape 4-Side Slots



NEFS6-60120
Clear Anodize

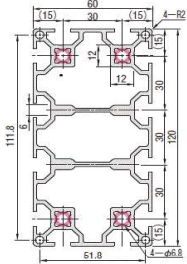

Material	Length	Weight	Section Area	Cross Sectional Moment of Inertia	
A6063S-T5	50-4000mm	4.53kg/m	1677mm ²	I _x 69.0×10 ⁴ mm ⁴	I _y 246.7×10 ⁴ mm ⁴

Square shape 3-Side Slots



NFSF6-6060
Clear Anodize

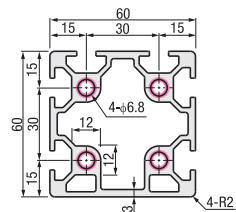

Material	Length	Weight	Section Area	Cross Sectional Moment of Inertia	
A6063S-T5	50-4000mm	2.90kg/m	1072mm ²	I _x 45.4×10 ⁴ mm ⁴	I _y 43.3×10 ⁴ mm ⁴

App. Example: Corner Bracket HBLCR

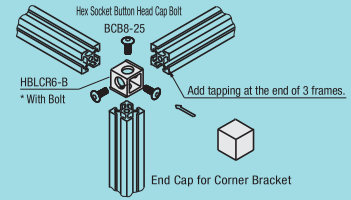

How to Use: Free Angle Brackets

Connection of Two Side Faces

Use 2 pcs. of HBLTBA to connect two frame sides with HBLTA20, Bolt and nuts.

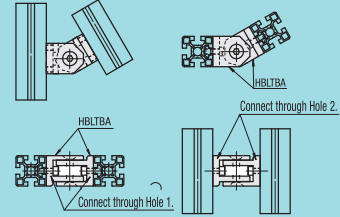

Conductive Washers Usage Procedure

Combining HDW and HUZW as shown below makes frames conductive.

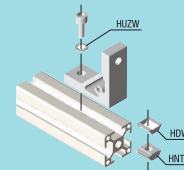
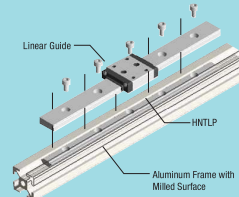

30 mm

(Series 6)

ALUMINUM FRAME

Slot Width 8: Series 30 for medium coverings, conveyor frames...

When ordering, select Part Number and Values from Selection Steps ❶-❸.



Ordering Example

❶ Part Number

NEFS6-606030

- ❷ L

1000

L shape

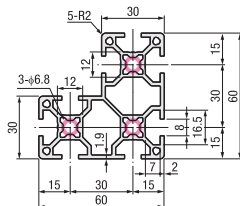

NEFS6-606030

Clear Anodize

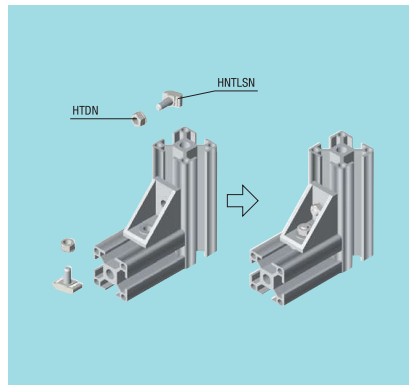

Material	Length	Weight	Section Area	Cross Sectional Moment of Inertia	
A6063S-T5	50~4000mm	2.21kg/m	819mm ²	I _x 27.38×10 ⁴ mm ⁴	I _y 27.38×10 ⁴ mm ⁴

■ Brackets

Tabbed Reversal Brackets (For 1 Slot)

HBLFSN6

HBLFSNB6

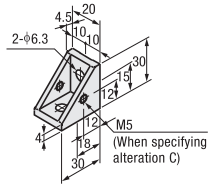

Part Number	Material	Surface Treatment
HBLFSN6	ADC12	-
HBLFSNB6	ADC12	Black Anodize

Tabbed Reversal Brackets (For 2 Slots)

HBLFSDW6

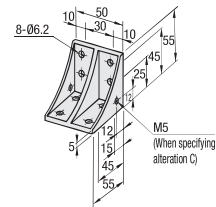

Part Number	Material	Surface Treatment
HBLFSDW6	ADC12	-

Tabbed Reversal Brackets (For 1 Slot)

HBLFSSW6

HBLFSSWB6

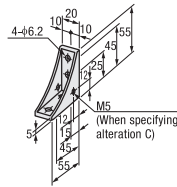

Part Number	Material	Surface Treatment
HBLFSSW6	ADC12	-
HBLFSSWB6	ADC12	Black Anodize

Tabbed Reversal Brackets (For 2 Slots)

HBLFSD6

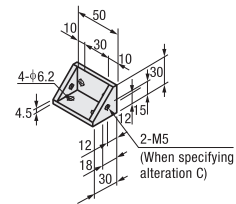

Part Number	Material	Surface Treatment
HBLFSD6	ADC12	-

One-Side Rib Brackets (For 1 Slot)

HBLFSL6

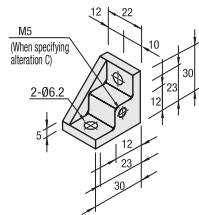

Part Number	Material	Surface Treatment
HBLFSL6	ADC12	-

Thick Brackets (For 2 Slots)

HBLTD6

HBLTDB6

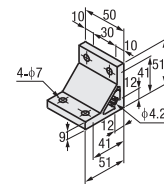
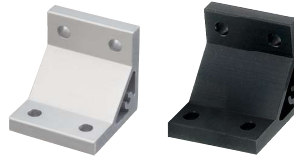

Part Number	Material	Surface Treatment
HBLTD6	A6N01SS-T5	Clear Anodize
HBLTDB6	A6N01SS-T5	Black Anodize

Thick Brackets (For 1 Slot)

HBLTS6

HBLTSB6

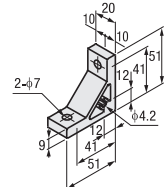

Part Number	Material	Surface Treatment
HBLTS6	A6N01SS-T5	Clear Anodize
HBLTSB6	A6N01SS-T5	Black Anodize

Ultra Thick Brackets (For 2 Slots)

HBLUD6

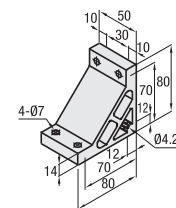

Part Number	Material	Surface Treatment
HBLUD6	A6N01SS-T5	Clear Anodize

Thin Brackets (For 1 Slot)

HBLSS6

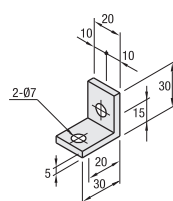

Part Number	Material	Surface Treatment
HBLSS6	A6N01SS-T5	Clear Anodize

Thick Brackets (For 3 Slots)

HBLTT6

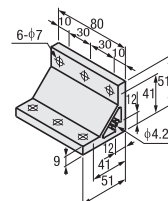

Part Number	Material	Surface Treatment
HBLTT6	A6N01SS-T5	Clear Anodize



Nuts

Post-Assembly Insertion Nuts

HNTF6

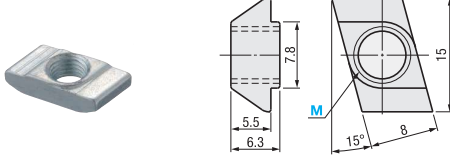

Part Number	M	Material	Surface Treatment
HNTF6	3 4 5 6	S10C Equivalent	Trivalent Chromate

Post-Assembly Insertion Spring Nuts

HNTP6

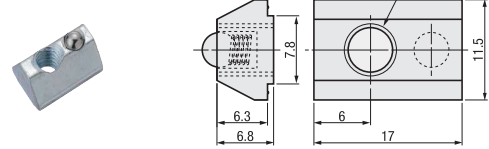

Part Number	M	Material			Surface Treatment
		Main Body	Ball	Spring	
HNTP6	3 4 5 6	S10C Equivalent	SUS304	SWP-A	Trivalent Chromate

Post-Assembly Insertion Stopper Nuts

HNTA6

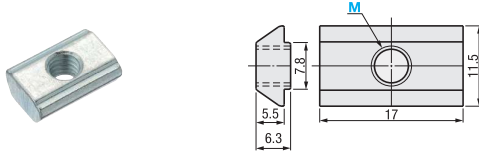

Part Number	M	Material	Surface Treatment
HNTA6	3 4 5 6	S10C Equivalent	Trivalent Chromate

Post-Assembly Insertion Nuts with Leaf Springs

HNTAP6

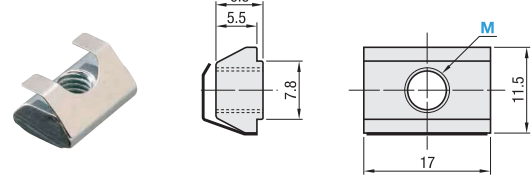

Part Number	M	Material	Surface Treatment
HNTAP6	3 4 5 6	S10C Equivalent	Trivalent Chromate

Pre-Assembly Insertion Nuts

HNTT6

HNTTSN6

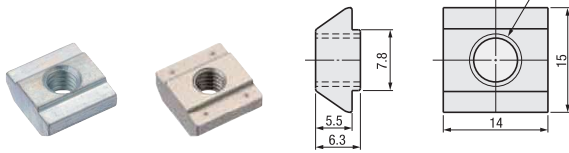

Part Number	M	Material	Surface Treatment
HNTT6	3 4 5 6	S10C Equivalent	Trivalent Chromate
HNTTSN6	3 4 5 6	SUS316 Equivalent	-

Pre-Assembly Insertion Spring Nuts

HNTU6

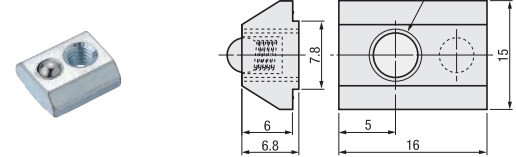

Part Number	M	Material			Surface Treatment
		Main Body	Ball	Spring	
HNTU6	3 4 5 6	S10C Equivalent	SUS304	SWP-A	Trivalent Chromate

Pre-Assembly Insertion Short Nuts

HNTJ6

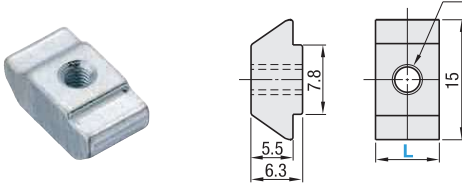

Part Number	M	Material	Surface Treatment
HNTJ6	4 5 6	S10C Equivalent	Trivalent Chromate

Example

Ordering Example

Part Number	-	M
HNTF6	-	4

Extrusion End Caps



HFC6-3030

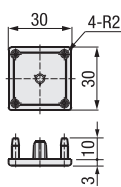

HFC6-3060

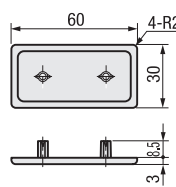

HFC6-3090

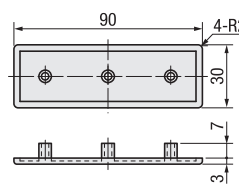

HFCR6-3030

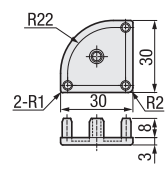

HFC6-5050

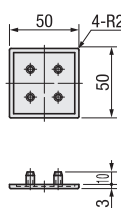

HFC6-606030

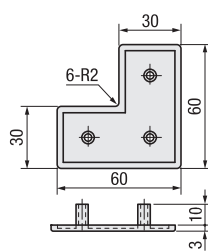

HFC6-6060

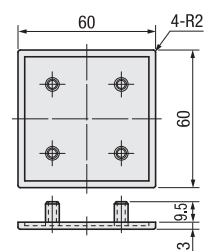

Part Number	Color	Material
HFC6-3030	B (Black), S (Light Gray)	Polyamide
HFC6-3060		
HFC6-3090		
HFC6-5050		
HFC6-606030		
HFC6-6060		
HFCR6-3030		

<Supplementary Information>

- Add-B (Black)/-S (Light Gray) to the end of the part number to specify the color.
Example) HFC6-3030-B



Example



Ordering Example

Part Number	-	Color
HFC6-3030	-	B

40 mm

(Series 8)

ALUMINUM FRAME

Slot Width 10mm: Series 40 for larger clean booths, equipment bases and structural materials
(40, 80mm square)

When ordering, select Part Number and Values from Selection Steps ①-③.



Ordering Example

① Part Number - ② L
NEFS8-4040 - 2000

Square shape 4-Side Slots



NEFS8-4040
Clear Anodize



NEFSB8-4040
Black Anodize

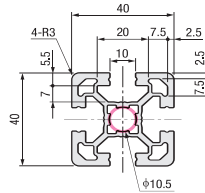

Material	Length	Weight	Section Area	Cross Sectional Moment of Inertia	
A6063S-T5	50-4000mm	1.61kg/m	596mm ²	I _x 10.5×10 ⁴ mm ⁴	I _y 10.5×10 ⁴ mm ⁴

Square shape 4-Side Slots, Light Weight



NFSL8-4040
Clear Anodize

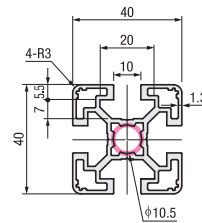

Material	Length	Weight	Section Area	Cross Sectional Moment of Inertia	
A6063S-T5	50-4000mm	1.27kg/m	478mm ²	I _x 7.54×10 ⁴ mm ⁴	I _y 7.54×10 ⁴ mm ⁴

Square shape 4-Side Slots, High Rigidity



GNFS8-4040
Clear Anodize

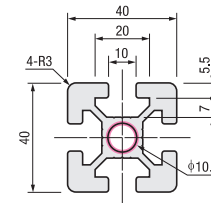

Material	Length	Weight	Section Area	Cross Sectional Moment of Inertia	
A6063S-T6	50-4000mm	2.17kg/m	806mm ²	I _x 13.76×10 ⁴ mm ⁴	I _y 13.76×10 ⁴ mm ⁴

Square shape 3-Side Slots



NEFS8-4040
Clear Anodize

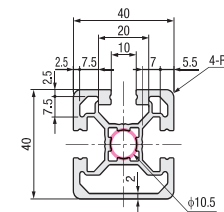

Material	Length	Weight	Section Area	Cross Sectional Moment of Inertia	
A6063S-T5	50-4000mm	1.53kg/m	568mm ²	I _x 9.96×10 ⁴ mm ⁴	I _y 10.12×10 ⁴ mm ⁴

Center Joint Connection Method

Step 1

Front View / Side View

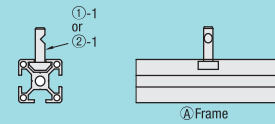

Standard Type

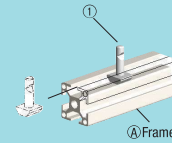

With Rotation Stopper

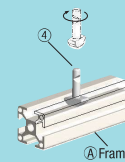

Explanation

Mount a center post to (A) frame. (Post Assembly Insertion Type can be inserted by turning from upside of the slot.)

Center Post is for Standard Type and With Rotation Stopper Type.

Step 2

Front View / Side View

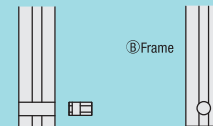

Standard Type

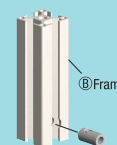

40 mm

(Series 8)

ALUMINUM FRAME

Slot Width 10mm: Series 40 for larger clean booths, equipment bases and structural materials
(40, 80mm square)

When ordering, select Part Number and Values from Selection Steps ①-③.



Ordering Example

① Part Number
NEFST8-4040

③ L
2000

Square shape 2-Side Slots



NEFST8-4040
Clear Anodize

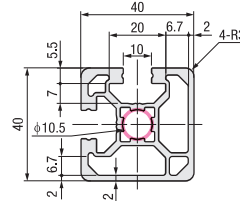

Material	Length	Weight	Section Area	Cross Sectional Moment of Inertia	
A6063S-T5	50~4000mm	1.51kg/m	558mm ²	$I_x 9.92 \times 10^4 \text{mm}^4$	$I_y 9.92 \times 10^4 \text{mm}^4$

R shape



NFSR8-4040
Clear Anodize

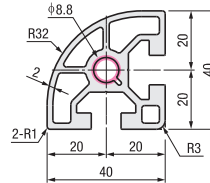

Material	Length	Weight	Section Area	Cross Sectional Moment of Inertia	
A6063S-T5	50~4000mm	1.53kg/m	564mm ²	$I_x 7.79 \times 10^4 \text{mm}^4$	$I_y 7.79 \times 10^4 \text{mm}^4$

Rectangle shape 4-Side Slots



NEFS8-4080
Clear Anodize



NEFSB8-4080
Clear Anodize

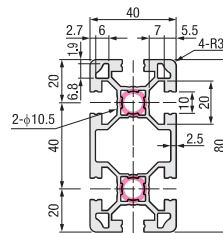

Material	Length	Weight	Section Area	Cross Sectional Moment of Inertia	
A6063S-T5	50~4000mm	2.79kg/m	1034mm ²	$I_x 19.9 \times 10^4 \text{mm}^4$	$I_y 72.6 \times 10^4 \text{mm}^4$

Rectangle shape 4-Side Slots, Light Weight



NFSL8-4080
Clear Anodize

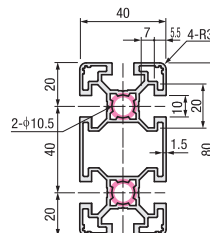

Material	Length	Weight	Section Area	Cross Sectional Moment of Inertia	
A6063S-T5	50~4000mm	2.12kg/m	785mm ²	$I_x 13.4 \times 10^4 \text{mm}^4$	$I_y 52.9 \times 10^4 \text{mm}^4$

With Rotation Stopper

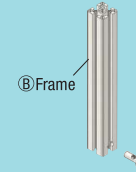

Explanation

Insert a joint guide in ② frame with M type hole. For standard type, adjust the through hole to be upward.

Step 3

Front View / Side View

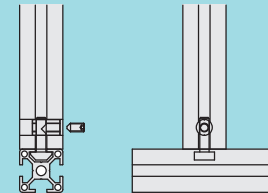

Standard Type



With Rotation Stopper

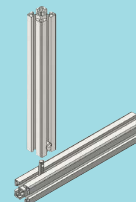

Explanation

Move ① frame close to ② frame while putting the center post through the through hole of joint guide.

40 mm

(Series 8)

ALUMINUM FRAME

Slot Width 10mm: Series 40 for larger clean booths, equipment bases and structural materials
(40, 80mm square)

When ordering, select Part Number and Values from Selection Steps ①~③.



Ordering Example

①② Part Number - ③ L
GNFS8-4080 - 1000

Rectangle shape 4-Side Slots, High Rigidity



GNFS8-4080
Clear Anodize

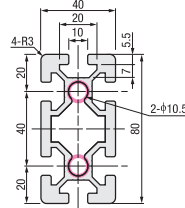

Material	Length	Weight	Section Area	Cross Sectional Moment of Inertia	
A6063S-T6	50~4000mm	3.62kg/m	1340mm ²	I _x 25.21×10 ⁴ mm ⁴	I _y 90.87×10 ⁴ mm ⁴

Rectangle shape 3-Side Slots

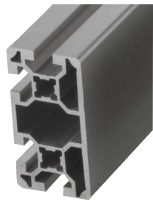

NEFSF8-4080
Clear Anodize

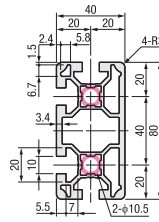

Material	Length	Weight	Section Area	Cross Sectional Moment of Inertia	
A6063S-T5	50~4000mm	2.81kg/m	1041mm ²	I _x 20.37×10 ⁴ mm ⁴	I _y 72.20×10 ⁴ mm ⁴

Rectangle shape 4-Side Slots



NEFS8-40120
Clear Anodize

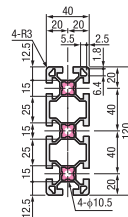

Material	Length	Weight	Section Area	Cross Sectional Moment of Inertia	
A6063S-T5	50~4000mm	3.98kg/m	1474mm ²	I _x 29.0×10 ⁴ mm ⁴	I _y 223.5×10 ⁴ mm ⁴

Rectangle shape 4-Side Slots



NFS8-40160
Clear Anodize

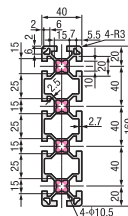

Material	Length	Weight	Section Area	Cross Sectional Moment of Inertia	
A6063S-T5	50~4000mm	5.25kg/m	1945mm ²	I _x 38.8×10 ⁴ mm ⁴	I _y 506×10 ⁴ mm ⁴

Center Joint Connection Method

Step 4

Front View / Side View

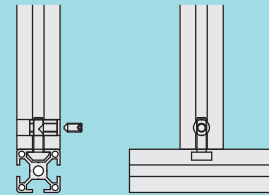

Standard Type

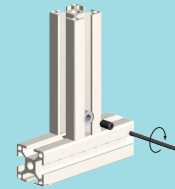

With Rotation Stopper

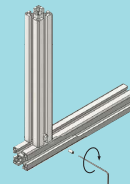

Explanation

Tighten the set screw to the side of joint guide.

Step 5

Front View / Side View

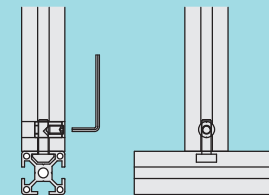

Standard Type

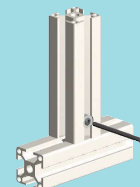

40 mm

(Series 8)

ALUMINUM FRAME

Slot Width 10mm: Series 40 for larger clean booths, equipment bases and structural materials (40, 80mm square)

When ordering, select Part Number and Values from Selection Steps ①-③.



Ordering Example

① Part Number - ② L
NEFS8-8080 - 1000

Square shape 4-Side Slots



NEFS8-8080
Clear Anodize

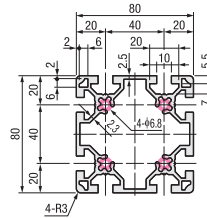

Material	Length	Weight	Section Area	Cross Sectional Moment of Inertia
A6063S-T5	50~4000mm	4.45kg/m	1649mm ²	$I_x 130.0 \times 10^4 \text{mm}^4$ $I_y 130.0 \times 10^4 \text{mm}^4$

L shape



NEFS8-808040
Clear Anodize

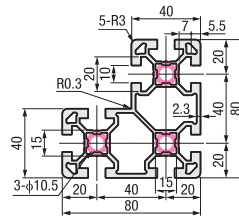

Material	Length	Weight	Section Area	Cross Sectional Moment of Inertia
A6063S-T5	50~4000mm	4.0kg/m	1484mm ²	$I_x 94.82 \times 10^4 \text{mm}^4$ $I_y 94.82 \times 10^4 \text{mm}^4$

L/R shape



NFSR8-808040
Clear Anodize

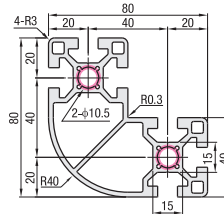

Material	Length	Weight	Section Area	Cross Sectional Moment of Inertia
A6063S-T5	50~4000mm	3.61kg/m	1339mm ²	$I_x 80.99 \times 10^4 \text{mm}^4$ $I_y 80.99 \times 10^4 \text{mm}^4$

How to Use: Free Angle Brackets

HBLTBA 40

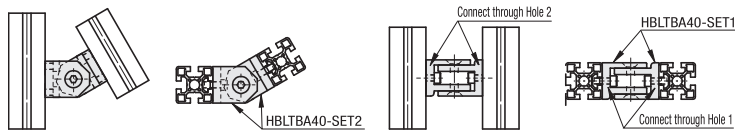

With Rotation Stopper

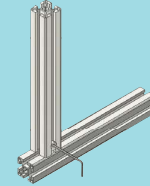

Explanation

When the set screw is tightened against a V slot on the center post, frame ㉑ and ㉒ frame are pulled and bound together.

- Product Number for the parts shown on the above example (Standard Type).

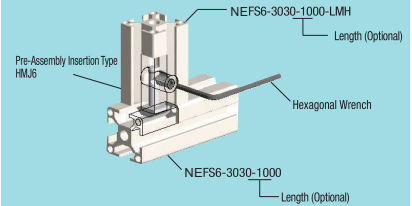

- Connecting frames with 2 or more slots on one side
Insert joint guide from the both sides of M type hole, and connect and tighten it with two or more center joints.
- For frames with three rows of slots, holes cannot be added on the center row. (For frames with four rows of slots, all slots are drilled.)

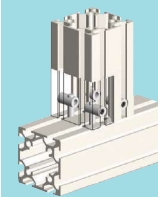

2-slotted frames can be connected by using two Center Joint kits.

③-slotted frames are connected using two outside slots only.

40 mm

(Series 8)

ACCESSORIES FOR ALUMINUM FRAME BRACKETS/NUTS/EXTRUSION END CAPS

■ Brackets

Tabbed Reversal Brackets (For 1 Slot)

HBLFSN8

HBLFSNB8

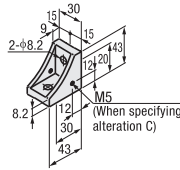

Part Number	Material	Surface Treatment
HBLFSN8	ADC12	-
HBLFSNB8		Black Anodize

Tabbed Reversal Brackets (For 2 Slots)

HBLFSD8

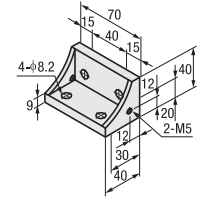

Part Number	Material	Surface Treatment
HBLFSD8	ADC12	-

Tabbed Reversal Brackets (For 1 Slot)

HBLFSSW8

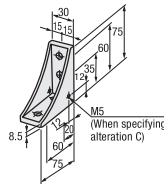

Part Number	Material	Surface Treatment
HBLFSSW8	ADC12	-

Thick Brackets (For 2 Slots)

HBLTD8

HBLTDB8

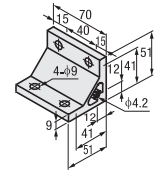

Part Number	Material	Surface Treatment
HBLTD8	A6N01SS-T5	Clear Anodize
HBLTDB8	A6N01SS-T5	Black Anodize

One-Side Rib Brackets (For 1 Slot)

HBLFSL8

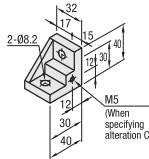

Part Number	Material	Surface Treatment
HBLFSL8	ADC12	-

Ultra Thick Brackets (For 2 Slots)

HBLUD8

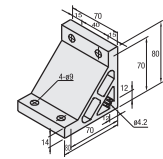

Part Number	Material	Surface Treatment
HBLUD8	A6N01SS-T5	Clear Anodize

Thick Brackets (For 1 Slot)

HBLTS8

HBLTSB8

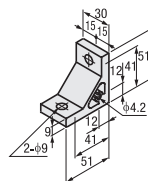

Part Number	Material	Surface Treatment
HBLTS8	A6N01SS-T5	Clear Anodize
HBLTSB8	A6N01SS-T5	Black Anodize

Ultra Thick Brackets (For 3 Slots)

HBLUT8

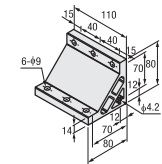

Part Number	Material	Surface Treatment
HBLUT8	A6N01SS-T5	Clear Anodize

Thin Brackets (For 1 Slot)

HBLSS8

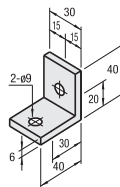

Part Number	Material	Surface Treatment
HBLSS8	A6N01SS-T5	Clear Anodize



Example

Can be installed in either direction.

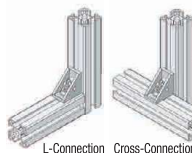

HBLFSN8 prevents brackets from protruding from extrusions when cross connected.

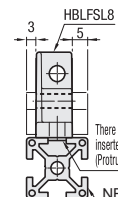
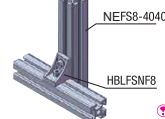

There are protrusions to be inserted into slots (Protrusion Dimension 1mm)

NEFS8-4040

Can be combined with both cover plates of 5mm and 3mm thickness.



Ordering Example

Part Number
HBLFSSW8

Nuts

Post-Assembly Insertion Nuts

HNTF8

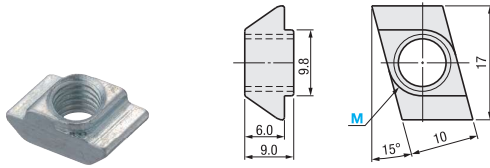

Part Number	M	Material	Surface Treatment
HNTF8	4 5 6 8	S10C Equivalent	Trivalent Chromate

Post-Assembly Insertion Spring Nuts

HNTP8

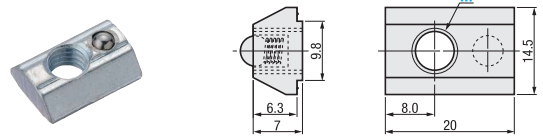

Part Number	M	Material			Surface Treatment
		Main Body	Ball	Spring	
HNTP8	3 4 5 6 8	S10C Equivalent	SUS304	SWP-A	Trivalent Chromate

Post-Assembly Insertion Stopper Nuts

HNTA8

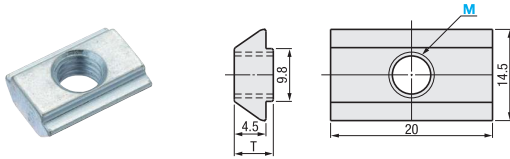

Part Number	M	Material	Surface Treatment
HNTA8	4 5 6 8	S10C Equivalent	Trivalent Chromate

Post-Assembly Insertion Nuts with Leaf Springs

HNTAP8

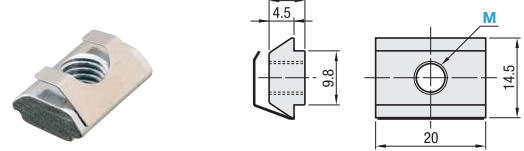

Part Number	M	Material	Surface Treatment
HNTAP8	4 5 6 8	S10C Equivalent	Trivalent Chromate

Pre-Assembly Insertion Nuts

HNTT8

HNTTSN8

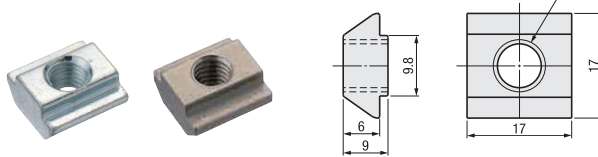

Part Number	M	Material	Surface Treatment
HNTT8	4 5 6 8	S10C Equivalent	Trivalent Chromate
HNTTSN8	4 5 6 8	SUS316 Equivalent	-

Pre-Assembly Insertion Spring Nuts

HNTU8

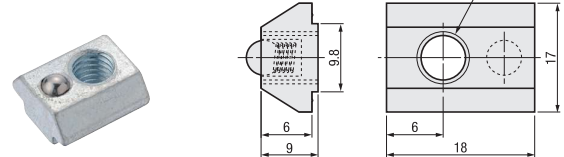

Part Number	M	Material			Surface Treatment
		Main Body	Ball	Spring	
HNTU8	4 5 6 8	S10C Equivalent	SUS304	SWP-A	Trivalent Chromate

Pre-Assembly Insertion Short Nuts

HNTJ8

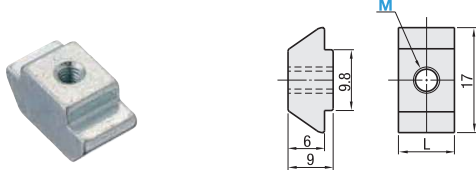

Part Number	M	Material	Surface Treatment
HNTJ8	3 4 8	S10C Equivalent	Trivalent Chromate

Example

• Hold Pre-Assembly Insertion Nuts temporarily in the extrusion.
• Nuts do not fall off.

Electrical conductivity between extrusions is achieved by combining HDW and HUZW.

Ordering Example

Part Number	-	M
HNTT8	-	8

Extrusion End Caps



HFC8-4040

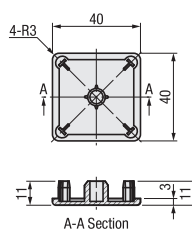

HFC8-4080

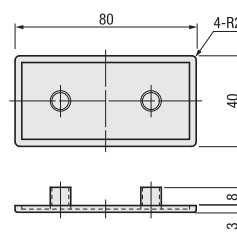

HFC8-40120

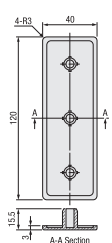

HFC8-8080

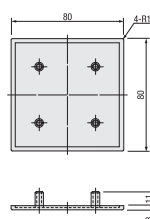

HFC8-808040

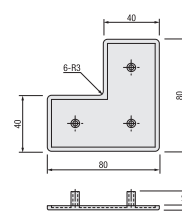

HFC8-4040

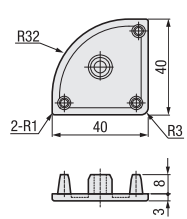

Part Number	Color	Material
HFC8-4040	B (Black), S (Light Gray)	Polyamide
HFC8-4080		
HFC8-40120		
HFC8-8080		
HFC8-808040		
HFC8-4040		

<Supplementary Information>

• Add-B (Black)/S (Light Gray) to the end of the part number to specify the color.
Example) HFC8-4040-B



Example



Ordering Example

Part Number	-	Color
HFC8-4040	-	B

45,50 mm

(Series 8-45)

ALUMINUM FRAME

Slot Width 10mm: Series 45, 50 for larger clean booths, equipment bases and structural materials (45, 50, 60, 90, 100mm square)

When ordering, select Part Number and Values from Selection Steps ①-③.



Ordering Example

①② Part Number - ③ L
NEFS8-4545 - 1000

Square shape 4-Side Slots



NEFS8-4545
Clear Anodize

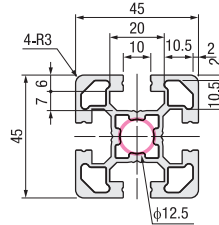

Material	Length	Weight	Section Area	Cross Sectional Moment of Inertia
A6063S-T5	50-4000mm	1.93kg/m	713mm ²	I _x 15.42×10 ⁴ mm ⁴ I _y 15.42×10 ⁴ mm ⁴

Square shape 4-Side Slots, Light Weight



NFSL8-4545
Clear Anodize

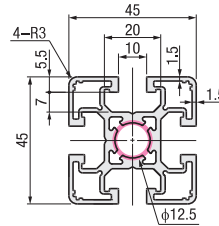

Material	Length	Weight	Section Area	Cross Sectional Moment of Inertia
A6063S-T5	50-4000mm	1.7kg/m	628mm ²	I _x 11.73×10 ⁴ mm ⁴ I _y 11.73×10 ⁴ mm ⁴

Square shape 4-Side Slots, High Rigidity



GNFS8-4545
Clear Anodize

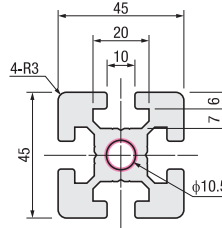

Material	Length	Weight	Section Area	Cross Sectional Moment of Inertia
A6063S-T6	50-4000mm	3.16kg/m	1171mm ²	I _x 23.64×10 ⁴ mm ⁴ I _y 23.64×10 ⁴ mm ⁴

Square shape 3-Side Slots



NEFS8-4545
Clear Anodize

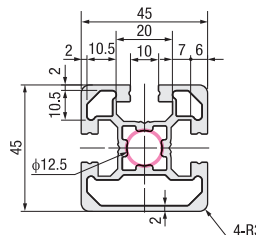

Material	Length	Weight	Section Area	Cross Sectional Moment of Inertia
A6063S-T5	50-4000mm	1.83kg/m	677mm ²	I _x 14.58×10 ⁴ mm ⁴ I _y 15.00×10 ⁴ mm ⁴

Standard of Frame Position

Placing method of the frame, which is a basis to determine right and left, is shown as follows.

- ① On the vertical length
- ② Flat side down
- ③ One flat side down and another flat side right

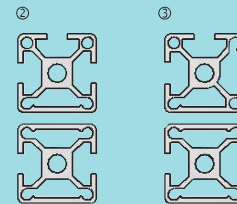
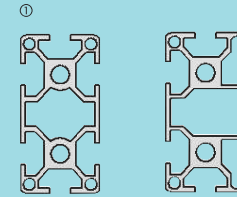

Example of L-Shaped

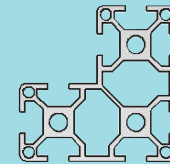

Combination of Alterations

When desiring multiple alterations to be applied simultaneously, repeat the process of specifying any alteration code.

Ordering Example

NEFS8-4545-200-LTP-RDH

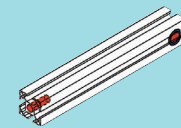

HFST8-6060-200-LWH-RWV

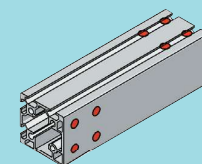

45,50 mm

(Series 8-45)

ALUMINUM FRAME

Slot Width 10mm: Series 45, 50 for larger clean booths, equipment bases and structural materials (45, 50, 60, 90, 100mm square)

When ordering, select Part Number and Values from Selection Steps ①-③.



Ordering Example

① Part Number

NEFST8-4545

③ L

1000

Square shape 2-Side Slots



NEFST8-4545
Clear Anodize

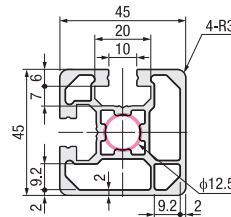

Material	Length	Weight	Section Area	Cross Sectional Moment of Inertia
A6063S-T5	50~4000mm	1.80kg/m	667mm ²	I _x 14.67×10 ⁴ mm ⁴ I _y 14.67×10 ⁴ mm ⁴

R shape



NFSR8-4545
Clear Anodize

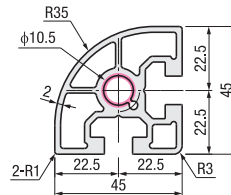

Material	Length	Weight	Section Area	Cross Sectional Moment of Inertia
A6063S-T5	50~4000mm	1.79kg/m	662mm ²	I _x 11.30×10 ⁴ mm ⁴ I _y 11.30×10 ⁴ mm ⁴

Rectangle shape 4-Side Slots

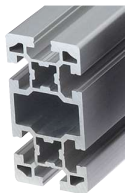

NEFS8-4590
Clear Anodize

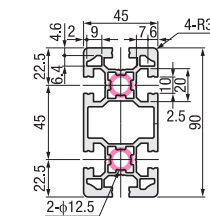

Material	Length	Weight	Section Area	Cross Sectional Moment of Inertia
A6063S-T5	50~4000mm	3.75kg/m	1390mm ²	I _x 32.67×10 ⁴ mm ⁴ I _y 125.3×10 ⁴ mm ⁴

Rectangle shape 4-Side Slots, Light Weight



NFSL8-4590
Clear Anodize

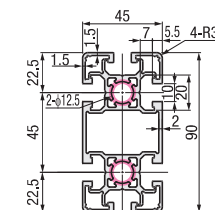

Material	Length	Weight	Section Area	Cross Sectional Moment of Inertia
A6063S-T5	50~4000mm	2.98kg/m	1101mm ²	I _x 22.87×10 ⁴ mm ⁴ I _y 87.16×10 ⁴ mm ⁴

Frame Cut Specifying Method

45° Cut

LCT45 : Adds a 45 degree cut on the left end in the specified direction.

RCT45 : Adds a 45 degree cut on the right end in the specified direction.

Limitation

- The cut direction can be specified as four directions against the cross section.
- In case of angled cut, it is impossible to specify other alterations in the same direction.

LAT, RAT: Cut with cross section facing down

Left

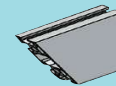

Right

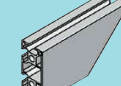

LBT, RBT: Cut with cross section facing back

Left

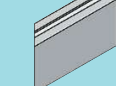

Right

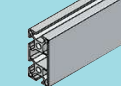

LCT, RCT: Cut with cross section facing up

Left

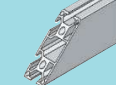

Right

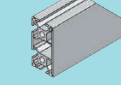

LDT, RDT: Cut with cross section facing front

Left

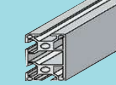

Right

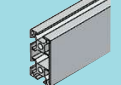

- The frame edges are cut at 45 degree angle.
(Ex.: NEFS6-3030-500-LCT45-RCT45)

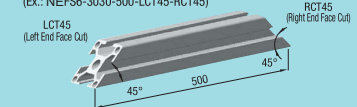

- For frames with the rectangle-shaped cross section such as NEFS6-3060, the main body shall be placed as shown in the illustration below, as standard.
(Ex.: NEFS6-3060-500-LCT45)

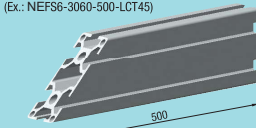

- When 45 Degree Cutting is machined to 2-side slotted frames (NEFST) or 3-side slotted frames (NEFSF), the standard orientation of frames are as shown below.

3-Side Slots: (Ex.: NEFSF6-3030-500-LCT45)

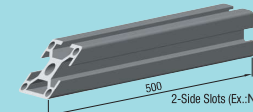

2-Side Slots (Ex.: NEFST6-3030-500-LCT45)

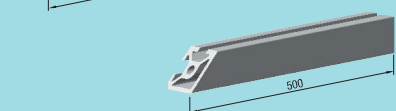

Place an frame frontwards with the smooth surface facing the bottom.

45,50 mm

(Series 8-45)

ALUMINUM FRAME

Slot Width 10mm: Series 45, 50 for larger clean booths, equipment bases and structural materials (45, 50, 60, 90, 100mm square)

When ordering, select Part Number and Values from Selection Steps ①-③.



Ordering Example

①② Part Number - ③ L
GNFS8-4590 - 1000

Rectangle shape 4-Side Slots, High Rigidity



GNFS8-4590
Clear Anodize

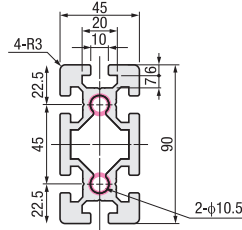

Material	Length	Weight	Section Area	Cross Sectional Moment of Inertia
A6063S-T6	50-4000mm	5.22kg/m	1935mm ²	I _x 42.99×10 ⁴ mm ⁴ I _y 163.4×10 ⁴ mm ⁴

Square shape 4-Side Slots



NFS8-9090
Clear Anodize

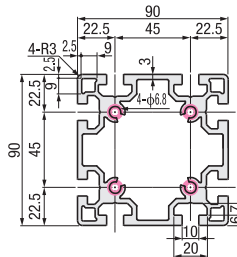

Material	Length	Weight	Section Area	Cross Sectional Moment of Inertia
A6063S-T5	50-4000mm	5.80kg/m	2162mm ²	I _x 209.2×10 ⁴ mm ⁴ I _y 209.2×10 ⁴ mm ⁴

Square shape 4-Side Slots, High Rigidity

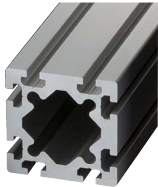

GNFS8-9090
Clear Anodize

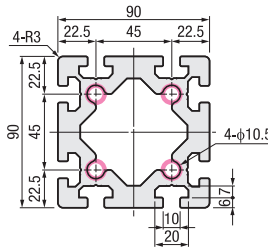

Material	Length	Weight	Section Area	Cross Sectional Moment of Inertia
A6063S-T6	50-4000mm	9.60kg/m	3592mm ²	I _x 320.2×10 ⁴ mm ⁴ I _y 320.2×10 ⁴ mm ⁴

L shape



NFS8-909045
Clear Anodize

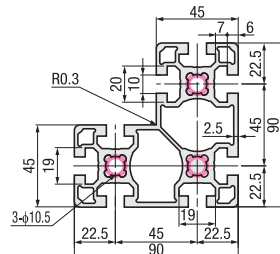

Material	Length	Weight	Section Area	Cross Sectional Moment of Inertia
A6063S-T5	50-4000mm	5.36kg/m	1988mm ²	I _x 149.72×10 ⁴ mm ⁴ I _y 149.72×10 ⁴ mm ⁴

Hole Position and Size

Frame Series	H (mm)	J (mm)
Slot Width 6mm (Series 5)	10	20
Slot Width 8mm (Series 6)	15	30
Slot Width 8mm Series 6 (For 50 Sq.)	15	20
Slot Width 10mm (Series 8)	20	40
Slot Width 10mm (Series 8-45)	22.5	45

Frame Series	K (mm)	Wrench Hole	
		d (mm)	
Slot Width 6mm (Series 5)	20	7.35	8
Slot Width 8mm (Series 6)	30		
Slot Width 8mm Series 6 (For 50 Sq.)	20		
Slot Width 10mm (Series 8)	40		
Slot Width 10mm (Series 8-45)	45		

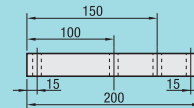

Ordering Example
NEFS6-3030-200-LCV-RCV-
AV100-BV150

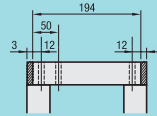

Ordering Example
NEFS6-3030-194-FL-LCV-FR-
RCV-AV50

Alteration Code Specifying Method (Wrench Hole is Specified Position)

- Adds a wrench hole in a desired position.
 - AH100** : Adds a wrench hole 100mm from the right end in the horizontal direction.
 - AV100** : Adds a wrench hole 100mm from the right end in the vertical direction.
 - AP100** : Adds a wrench hole 100mm from the right end in the crisscross direction.

⊙ For wrench hole machining, specify the hole position in 0.5mm increment.

0.5mm increment	
Code	AH, BH, CH, DH, EH, AV, BV, CV, DV, EV AP, BP, CP, DP, EP

- Offsets the wrench hole for the thickness of Frame End Cap. (Free of Charge)

In order to make the frame and the frame end cap flat, shortens the frame length by 3mm.

- FL : Shifts the wrench hole on the left side 3mm toward the left end.
- FR : Shifts the wrench hole on the right side 3mm toward the right end.

45,50 mm

(Series 8-45)

ALUMINUM FRAME

Slot Width 10mm: Series 45, 50 for larger clean booths, equipment bases and structural materials (45, 50, 60, 90, 100mm square)

When ordering, select Part Number and Values from Selection Steps ①-③.



Ordering Example

① Part Number
NFS8-6060

③ L
1000

Square shape 4-Side Slots



NFS8-6060
Clear Anodize

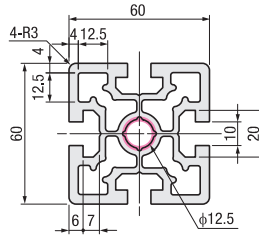

Material	Length	Weight	Section Area	Cross Sectional Moment of Inertia	
A6063S-T5	50~4000mm	4.17kg/m	1478mm ²	$I_x 56.44 \times 10^4 \text{mm}^4$	$I_y 56.44 \times 10^4 \text{mm}^4$

Square shape 4-Side Slots, High Rigidity



GNFS8-6060
Clear Anodize

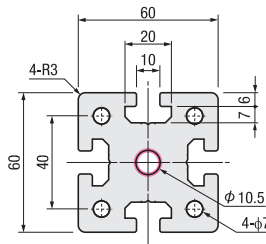

Material	Length	Weight	Section Area	Cross Sectional Moment of Inertia	
A6063S-T6	50~4000mm	6.96kg/m	2577mm ²	$I_x 79.86 \times 10^4 \text{mm}^4$	$I_y 79.86 \times 10^4 \text{mm}^4$

Square shape 4-Side Slots



NFS8-5050
Clear Anodize



NFS8-5050
Black Anodize

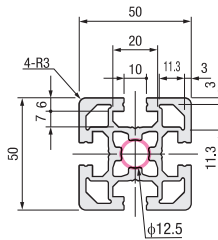

Material	Length	Weight	Section Area	Cross Sectional Moment of Inertia	
A6063S-T5	50~4000mm	2.84kg/m	1053mm ²	$I_x 26.98 \times 10^4 \text{mm}^4$	$I_y 26.98 \times 10^4 \text{mm}^4$

Square shape 4-Side Slots, High Rigidity



GNFS8-5050
Clear Anodize

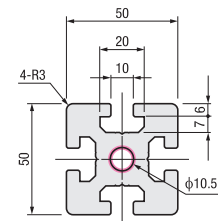

Material	Length	Weight	Section Area	Cross Sectional Moment of Inertia	
A6063S-T6	50~4000mm	4.40kg/m	1633mm ²	$I_x 38.16 \times 10^4 \text{mm}^4$	$I_y 38.16 \times 10^4 \text{mm}^4$

Wrench access holes used for Blind Joint connections, etc. are drilled.

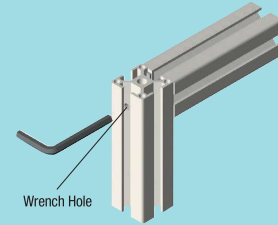

1 Row (C)

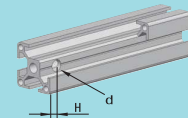

2 Rows (W)

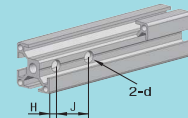

3 Rows (E)

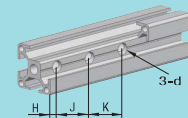

Cross Section View

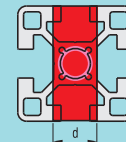

Alteration Code Specifying Method (Wrench Hole)

Drilling option is specifiable by combining symbols in the first, second and third column in the table.
 Drills 2 rows of wrench holes horizontally on the left side of the frame. **-LWH**
 Drills 2 rows of wrench holes crisscross on the left side of the frame. **-LWP**

Meaning of Option Symbols		
First	Second	Third
L (Left) R (Right)	C (Wrench Holes in Single Line) W (Wrench Holes in Two Lines) E (Wrench Holes in Three Lines)	H (Horizontal) V (Vertical) P (Crisscross)

45,50 mm

(Series 8-45)

ALUMINUM FRAME

Slot Width 10mm: Series 45, 50 for larger clean booths, equipment bases and structural materials (45, 50, 60, 90, 100mm square)

When ordering, select Part Number and Values from Selection Steps ①~③.



Ordering Example

①② Part Number - ③ L
NEFS8-50100 - 1000

Rectangle shape 4-Side Slots



NEFS8-50100
Clear Anodize



NEFSB8-50100
Black Anodize

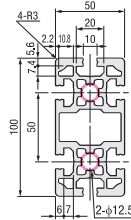

Material	Length	Weight	Section Area	Cross Sectional Moment of Inertia	
A6063S-T5	50-4000mm	5.39kg/m	1996mm ²	I _x 53.0×10 ⁴ mm ⁴	I _y 211.21×10 ⁴ mm ⁴

Rectangle shape 4-Side Slots, High Rigidity



GNFS8-50100
Clear Anodize

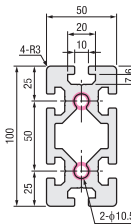

Material	Length	Weight	Section Area	Cross Sectional Moment of Inertia	
A6063S-T6	50-4000mm	7.0kg/m	2593mm ²	I _x 68.08×10 ⁴ mm ⁴	I _y 273.12×10 ⁴ mm ⁴

Square shape 4-Side Slots



NEFS8-100100
Clear Anodize

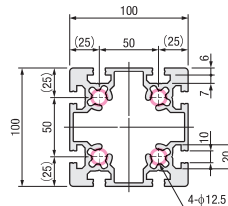

Material	Length	Weight	Section Area	Cross Sectional Moment of Inertia	
A6063S-T5	50-4000mm	7.86kg/m	2922mm ²	I _x 376.0×10 ⁴ mm ⁴	I _y 376.0×10 ⁴ mm ⁴

Square shape 4-Side Slots, High Rigidity



GNFS8-100100
Clear Anodize

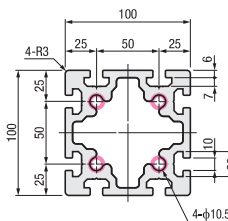

Material	Length	Weight	Section Area	Cross Sectional Moment of Inertia	
A6063S-T6	50-4000mm	10.68kg/m	3957mm ²	I _x 465.8×10 ⁴ mm ⁴	I _y 465.8×10 ⁴ mm ⁴

Alteration Code Specifying Method (Counterbore)

Alterations	Counterboring			
	Z Selection			
Code	Frame Series	Z	d	d1
Specify Counterbores and Locations	Series 5	5	5.5	9.5
		6	6.5	11
	Series 6 Series 8 Series 8-4G	8	9	14

Alterations	Counterboring				
	XA	XB	XC	XD	XE
Code	YA	YB	YC	YD	YE
Spec.	Distance from the Left End (0.5mm Increment)				
Specify Counterbores and Locations	7-(L-7)				

Ordering Example: NEFS6-3030-500-Z6-XA200-XB256

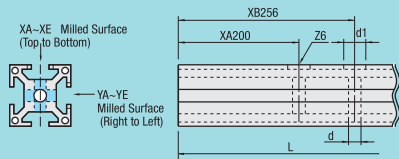

45,50 mm

(Series 8-45)

ALUMINUM FRAME

Slot Width 10mm: Series 45, 50 for larger clean booths, equipment bases and structural materials (45, 50, 60, 90, 100mm square)

When ordering, select Part Number and Values from Selection Steps ❶-❸.



Ordering Example

❶ Part Number

GNFS8-100200

- ❷ L

- 1000

Rectangle shape 4-Side Slots, High Rigidity



GNFS8-100200

Clear Anodize

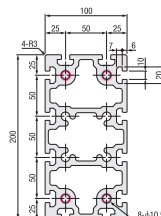

Material	Length	Weight	Section Area	Cross Sectional Moment of Inertia	
A6063S-T6	50~4000mm	20.45kg/m	7574mm ²	$I_x 874.3 \times 10^4 \text{mm}^4$	$I_y 3179.53 \times 10^4 \text{mm}^4$

45,50 mm

(Series 8-45)

ACCESSORIES FOR ALUMINUM FRAME BRACKETS/NUTS/EXTRUSION END CAPS

■ Brackets

Tabbed Reversal Brackets (For 1 Slot)

HBLFSN8-45



HBLFSNB8-45

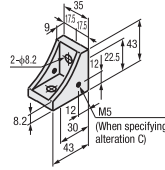

Part Number	Material	Surface Treatment
HBLFSN8-45	ADC12	-
HBLFSNB8-45		Black Anodize

Tabbed Reversal Brackets (For 2 Slots) For 90 Square

HBLFSDW8-90

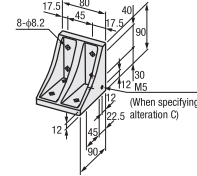

Part Number	Material	Surface Treatment
HBLFSDW8-90	ADC12	-

Tabbed Reversal Brackets (For 1 Slot)

HBLFSSW8-45

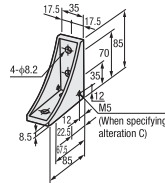

Part Number	Material	Surface Treatment
HBLFSSW8-45	ADC12	-

Thick Brackets (For 2 Slots)

HBLTD8-45

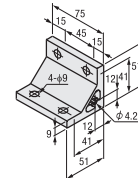

Part Number	Material	Surface Treatment
HBLTD8-45	A6N01SS-T5	Clear Anodize

Tabbed Reversal Brackets (For 1 Slot)

HBLFSN8-50

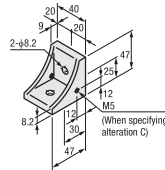

Part Number	Material	Surface Treatment
HBLFSN8-50	ADC12	-

Thick Brackets (For 2 Slots) For 100 Square

HBLTD8-100

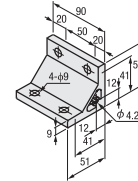

Part Number	Material	Surface Treatment
HBLTD8-100	A6N01SS-T5	Clear Anodize

Thick Brackets (For 1 Slot)

HBLTS8-45

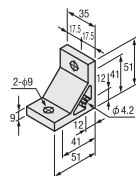

Part Number	Material	Surface Treatment
HBLTS8-45	A6N01SS-T5	Clear Anodize

Ultra Thick Brackets (For 2 Slots)

HBLUD8-45

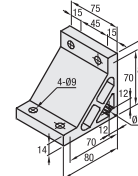

Part Number	Material	Surface Treatment
HBLUD8-45	A6N01SS-T5	Clear Anodize

Thin Brackets (For 4 Slots)

HBLSD8-45

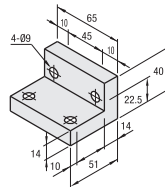
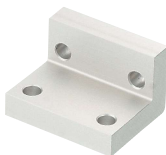

Part Number	Material	Surface Treatment
HBLSD8-45	A6N01SS-T5	Clear Anodize



Example

HBLTS845-6R

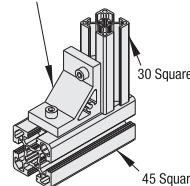

Ordering
Example

Part Number
HBLFSSW8-45

Nuts

Post-Assembly Insertion Nuts

HNTF8

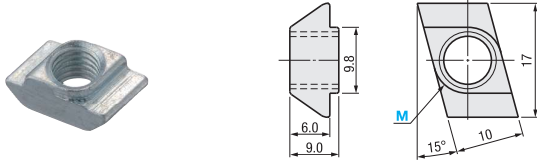

Part Number	M	Material	Surface Treatment
HNTF8	4 5 6 8	S10C Equivalent	Trivalent Chromate

Post-Assembly Insertion Spring Nuts

HNTP8

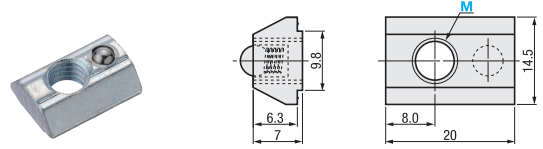

Part Number	M	Material			Surface Treatment
		Main Body	Ball	Spring	
HNTP8	3 4 5 6 8	S10C Equivalent	SUS304	SWP-A	Trivalent Chromate

Post-Assembly Insertion Stopper Nuts

HNTA8

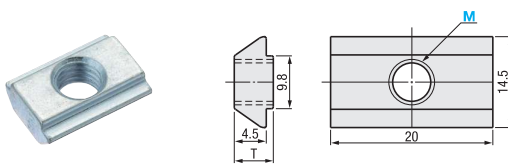

Part Number	M	Material	Surface Treatment
HNTA8	4 5 6 8	S10C Equivalent	Trivalent Chromate

Post-Assembly Insertion Nuts with Leaf Springs

HNTAP8

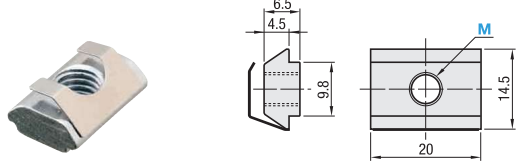

Part Number	M	Material	Surface Treatment
HNTAP8	4 5 6 8	S10C Equivalent	Trivalent Chromate

Pre-Assembly Insertion Nuts

HNTT8

HNTTSN8

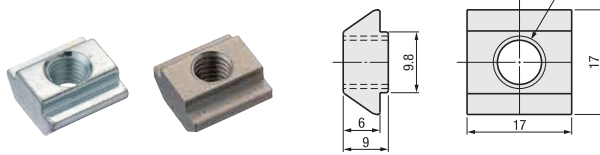

Part Number	M	Material	Surface Treatment
HNTT8	4 5 6 8	S10C Equivalent	Trivalent Chromate
HNTTSN8	4 5 6 8	SUS316 Equivalent	-

Pre-Assembly Insertion Spring Nuts

HNTU8

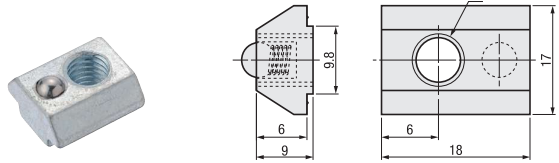

Part Number	M	Material			Surface Treatment
		Main Body	Ball	Spring	
HNTU8	4 5 6 8	S10C Equivalent	SUS304	SWP-A	Trivalent Chromate

Pre-Assembly Insertion Short Nuts

HNTJ8

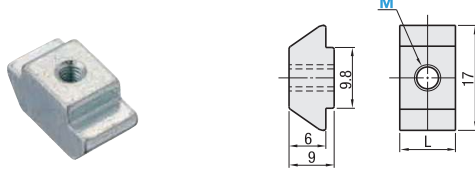

Part Number	M	Material	Surface Treatment
HNTJ8	3 4 8	S10C Equivalent	Trivalent Chromate

Example

Post-Assembly Insertion Nuts

Pre-Assembly Insertion Nuts

Ordering Example: Part Number - M
HNTT8 - 8

Extrusion End Caps



Part Number	Color	Material
HFC8-4545	B (Black), S (Light Gray)	Polyamide
HFC8-4590		
HFC8-5050		
HFC8-50100		
HFC8-909045		
HFC8-4545		

HFC8-4545

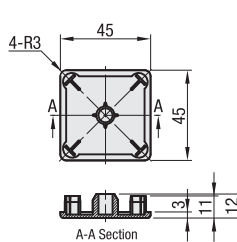

HFC8-4590

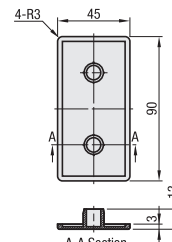

HFC8-5050

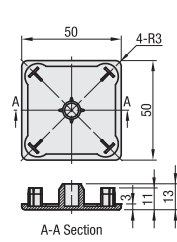

HFC8-50100

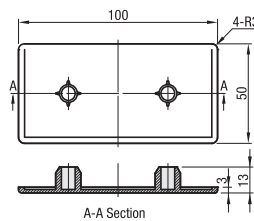

HFC8-909045

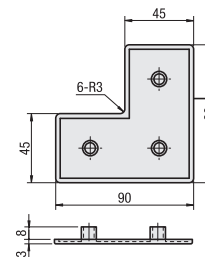

HFC8-4545

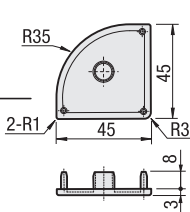

<Supplementary Information>

- Add -B (Black)/-S (Light Gray) to the end of the part number to specify the color.
Example) HFC8-4545-B



Part Number - Color
HFC8-4545 - B

Aluminum Extrusions Load Capacity Guideline

Load Capacity Calculations

1. Calculation Conditions: Calculations are based on centralized loads on both ends supported extrusions.
2. The load capacities (allowable loads) are defined as: Load that generates a deflection amount 1/1000 of the extrusion length.
These loads are the allowed maximum. Use within the given capacities.

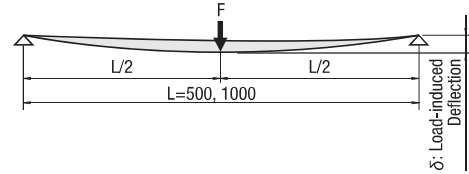

Part Number		Height x Width (mm)	Section Modulus x 10 ³ (mm ³)	Cross Sectional Moment of Inertia x 10 ⁴ (mm ⁴)	For 500mm Extrusion Length		For 1000mm Extrusion Length		
Type	Extrusion				Allowable Load (N)	Allowable Load (kgf)	Allowable Load (N)	Allowable Load (kgf)	
NFS5	2020	(1)	20x 20	0.74	0.74	99	10	24	2
	2040	(2)	20x 40	1.35	1.35	182	18	45	4
		(3)	40x 20	2.55	5.11	687	70	171	17
	2060	(4)	20x 60	1.97	1.97	264	26	66	6
		(5)	60x 20	5.32	15.96	2144	218	536	54
	2080	(6)	20x 80	2.58	2.58	347	35	86	8
		(7)	80x 20	9.02	36.11	4851	494	1212	123
	2525	(8)	25x 25	1.36	1.71	229	23	57	5
		(9)	25x 50	2.37	2.96	398	40	99	10
	2550	(10)	50x 25	5.09	12.74	1711	174	427	43
		4040	(11)	40x 40	4.45	8.9	1196	122	299
	4060	(12)	40x 60	6.3	12.62	1695	172	423	43
		(13)	60x 40	9	27	3627	369	906	92
	4080	(14)	40x 80	9.18	18.38	2469	251	617	62
		(15)	80x 40	15.87	63.49	8529	869	2132	217
NFS6	6060	(16)	60x 60	13.78	41.35	5555	566	1388	141
	6090	(17)	60x 90	17.53	52.59	7065	720	1766	180
		(18)	90x 60	24.77	111.5	14979	1527	3744	381
	5050	(19)	50x 50	8.66	21.66	2909	296	727	74
	50100	(20)	50x 100	16.98	42.44	5701	581	1425	145
		(21)	100x 50	30.63	153.2	20581	2098	5145	524
100100	(22)	100x 100	53.08	265.4	35655	3635	8913	908	
NFS8	9090	(23)	90x 90	46.78	210.5	28279	2883	7069	720
	6060	(24)	60x 60	17.3	51.91	6973	711	1743	177
		(25)	40x 160	19.47	38.8	5203	530	1300	132
	40160	(26)	160x 40	63.17	506	67114	6843	16778	1710
NFSL6	3030	(27)	30x 30	1.78	2.68	360	36	90	9
	3060	(28)	30x 60	3.24	4.87	654	66	163	16
		(29)	60x 30	5.95	17.88	2402	244	600	61
NFSL8	4040	(30)	40x 40	3.77	7.54	1013	103	253	25
	4080	(31)	40x 80	6.71	13.43	1804	183	451	45
		(32)	80x 80	13.25	52.98	7117	725	1779	181
	4545	(33)	45x 45	5.21	11.73	1575	160	393	40
		(34)	45x 90	10.15	22.85	3069	313	767	78
4590	(35)	90x 45	19.26	86.68	11645	1187	2911	296	
NEFS6	3030	(36)	30x 30	1.89	2.85	382	39	95	9
	3060	(37)	30x 60	3.66	5.48	736	75	184	19
		(38)	60x 30	6.86	20.46	2758	281	689	70
	3090	(39)	30x 90	5.86	8.8	1181	120	295	30
		(40)	90x 30	15.19	69	9185	2296	936	234
	30120	(41)	30x 120	7.65	11.48	1583	161	395	40
		(42)	120x 30	26.29	157.62	20628	2103	5157	525
	60120	(43)	60x 120	23.06	69.18	9294	947	2323	236
(44)		120x 60	41.18	247.1	33196	3385	8299	846	
NEFS8	4040	(45)	40x 40	5.24	10.49	1409	144	352	35
	4080	(46)	40x 80	9.96	19.93	2677	273	669	68
		(47)	80x 40	18.13	72.55	9745	994	2436	248
	40120	(48)	40x 120	14.5	29	3940	401	985	100
		(49)	120x 40	37.03	223.51	29958	3054	7489	763
	8080	(50)	80x 80	32.55	130	17494	1783	4373	445
	80160	(51)	80x 160	75.85	304.4	40708	4151	10177	1037
		(52)	160x 80	125.86	1007	134584	13723	33646	3430
	4545	(53)	45x 45	6.85	15.42	2071	211	517	53
		(54)	45x 90	14.52	32.67	4389	448	1097	112
	4590	(55)	90x 45	27.84	125.3	16860	1719	4215	430
		(56)	50x 50	10.79	26.98	3665	374	916	93
	50100	(57)	50x 100	21.2	53	7120	726	1780	182
		(58)	100x 50	42.24	211.2	28385	2894	7094	723

Part Number		Height x Width (mm)	Section Modulus $\times 10^3$ (mm ³)	Cross Sectional Moment of Inertia $\times 10^4$ (mm ⁴)	For 500mm Extrusion Length		For 1000mm Extrusion Length	
Type	Extrusion				Allowable Load		Allowable Load	
					(N)	(kgf)	(N)	(kgf)
GNFS6	3030	(59) 30x 30	2.32	3.47	466	48	117	12
	3060	(60) 30x 60	3.96	5.9	792	81	199	20
		(61) 60x 30	7.95	23.78	3194	326	798	81
GNFS8	4040	(62) 40x 40	6.83	13.76	1848	188	462	47
	4080	(63) 40x 80	12.56	25.21	3384	345	846	86
		(64) 80x 40	22.47	90.87	12208	1245	3052	311
	4545	(65) 45x 45	10.42	23.64	3172	323	793	81
	4590	(66) 45x 90	18.87	42.99	5772	589	1443	147
		(67) 90x 45	35.67	163.4	21792	2222	5448	556
	5050	(68) 50x 50	15.23	38.16	5124	523	1281	131
	50100	(69) 50x 100	27.23	68.08	9147	932	2286	223
		(70) 100x 50	54.62	273.1	36706	3742	9173	935
	6060	(71) 60x 60	26.58	79.86	10728	1094	2682	273
	9090	(72) 90x 90	71.17	320.2	43016	4386	10754	1097
	100100	(73) 100x 100	93.48	465.8	62576	6381	15644	1595
	100200	(74) 100x 200	174.8	874.3	117507	11982	29365	2994
		(75) 200x 100	317.7	3179	427334	43576	106791	10890

Aluminum Extrusions Load Capacity Guideline

Load Capacity Guideline for Extrusion Frame Units

Condition: Calculated as: Loads causing 1mm deflection at the center of each extrusion of a 1000mm x 1000mm square frame.

Part Number		Height x Width (mm)	Allowable Load			
Type	Extrusion		Centralized Load		Evenly Distributed Load	
			(N)	(kgf)	(N)	(kgf)
NFS5	2020	20x 20	99	10	199	20
	2040	20x 40	182	18	364	37
	2060	40x 20	687	70	1375	140
		20x 60	264	26	529	53
	2080	60x 20	2144	218	4288	437
		20x 80	347	35	694	70
	2525	80x 20	4851	494	9702	989
		25x 25	229	23	459	46
	2550	25x 50	398	40	797	81
		50x 25	1711	174	3423	349
4040	40x 40	1196	121	2393	244	
4060	40x 60	1695	172	3390	345	
	60x 40	3627	369	7254	739	
4080	40x 80	2469	251	4938	503	
	80x 40	8529	869	17059	1739	
NFS6	6060	60x 60	5555	566	11110	1132
	6090	60x 90	7065	720	14130	1440
		90x 60	14979	1527	29959	3054
	5050	50x 50	2909	296	5819	593
	50100	50x 100	5701	581	11403	1162
		100x 50	20581	2098	41163	4197
100100	100x 100	35654	3635	71310	7271	
NFS8	9090	90x 90	28279	2883	56559	5767
	6060	60x 60	6973	711	13947	1422
	40160	40x 160	5203	530	10407	1061
160x 40		67114	6843	134228	13687	
NFSL6	3030	30x 30	360	36	720	73
	3060	30x 60	654	66	1309	133
		60x 30	2402	244	4804	489
NFSL8	4040	40x 40	1013	103	2027	206
	4080	40x 80	1804	183	3608	367
		80x 40	7124	726	14235	1451
	4545	45x 45	1575	160	3151	321
	4590	45x 90	3071	313	6139	626
NEFS6	3030	30x 30	382	39	765	78
		30x 60	736	75	1472	150
	3060	60x 30	2758	281	5516	562
		30x 90	1181	120	2362	240
	3090	90x 30	9185	2296	18371	1873
		30x 120	1583	161	3166	322
	30120	120x 30	20628	2103	41257	4207
		60x 120	9293	947	18588	1895
60120	120x 60	33196	3385	66393	6770	
NEFS8	4040	40x 40	1409	144	2818	287
	4080	40x 80	2677	273	5355	546
		80x 40	9745	994	19493	1988
	40120	40x 120	3940	401	7881	803
		120x 40	29958	3054	59916	6109
	8080	80x 80	17494	1783	34988	3567
	80160	80x 160	40708	4151	81417	8302
		160x 80	134584	13723	269168	27447
	4545	45x 45	2071	211	4143	422
	4590	45x 90	4389	448	8778	895
		90x 45	16860	1719	33720	3438
	5050	50x 50	3665	374	7330	747
	50100	50x 100	7120	726	14240	1452
100x 50		28385	2894	56748	5787	

Centralized Load: Concentrated load is applied at the center.

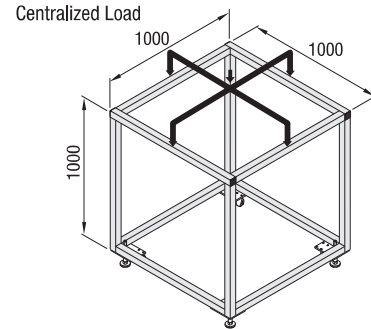

Evenly Distributed Load: When the load is evenly distributed over the extrusion.

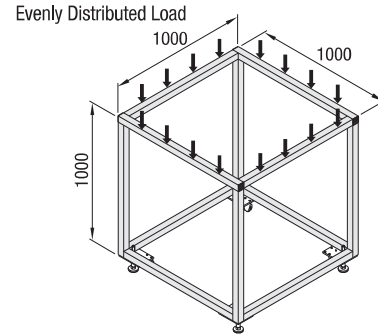

Part Number		Height x Width (mm)	Allowable Load			
Type	Extrusion		Centralized Load		Evenly Distributed Load	
			(N)	(kgf)	(N)	(kgf)
GNFS6	3030	30x 30	466	48	932	95
	3060	30x 60	792	81	1585	162
		60x 30	3194	326	6389	651
GNFS8	4040	40x 40	1848	188	3696	377
	4080	40x 80	3384	345	6768	690
		80x 40	12208	1245	24416	2490
	4545	45x 45	3172	323	6344	647
	4590	45x 90	5772	589	11544	1177
		90x 45	21792	2222	43584	4444
	5050	50x 50	5124	523	10248	1045
	50100	50x 100	9147	932	18292	1865
		100x 50	36706	3742	73380	7482
	6060	60x 60	10728	1094	21456	2188
	9090	90x 90	43016	4386	86032	8773
	100100	100x 100	62576	6381	125152	12762
	100200	100x 200	117507	11982	234918	23955
200x 100		427334	43576	854170	87101	

Centralized Load: Concentrated load is applied at the center.

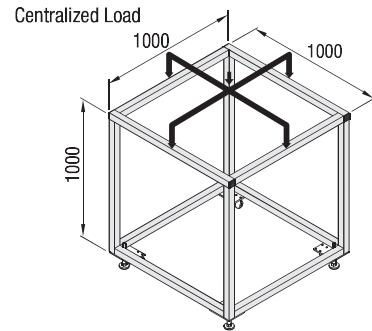

Evenly Distributed Load: When the load is evenly distributed over the extrusion.

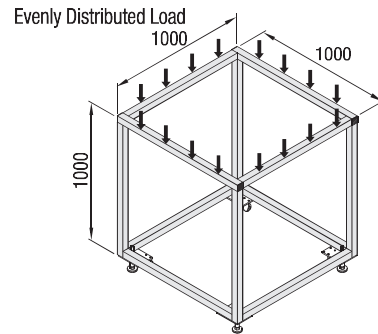

Aluminum Extrusion Tolerance Data

Aluminum Extrusion JIS Standards

• Bend Tolerance (Special Grade)

Unit: mm

Diameter of Circumscribed Circle mm	Minimum Thickness mm	Per Arbitrary Section of 300mm Length	per Full Length (L) mm
38 or less	2.4 or less	1.3 or less	$1.3 \times \frac{L}{300}$ or Less
	Over 2.4	0.3 or less	$0.3 \times \frac{L}{300}$ or Less
Over 38 to 300 or less	-	0.3 or less	$0.3 \times \frac{L}{300}$ or Less
Over 300	-	0.5 or less	$0.5 \times \frac{L}{300}$ or Less

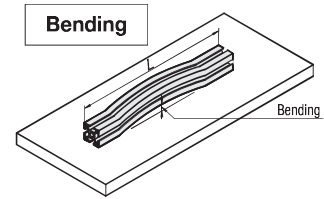

Note

- Given values are for extrusions placed on flat surfaces with minimized bends by own weight.
- When the overall length is not an integral multiple of 300mm, determine the tolerance by rounding up the remainder length to 300mm.

• Flatness Tolerance

Unit: mm

Shape Type Minimum Thickness of Measurement Point Width	General Shape	Hollow Shape	
	-	4.7mm or Less	Over 4.7mm
25mm or Less	0.10 or less	0.15 or less	0.10 or less
Over 25mm	0.004xW or Less	0.006xW or Less	0.004xW or Less
Per Arbitrary Section of 25mm Width	0.10 or less	0.15 or less	0.10 or less

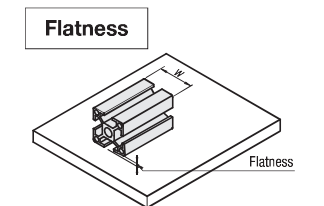

Note

Not Applicable to the plane including open section.

• Twist Tolerance

Unit: degree

Diameter of Circumscribed Circle mm	Length	
	Per Arbitrary Section of 300mm Length	per Full Length (L) mm
38 or less	1 or less	$1 \times \frac{L}{300}$ or Less; However, Max. Value is 7
Over 38 to 76 or less	1/2 or less	$\frac{1}{2} \times \frac{L}{300}$ or Less; However, Max. Value 5
Over 76	1/4 or less	$\frac{1}{4} \times \frac{L}{300}$ or Less; However, Max. Value 3

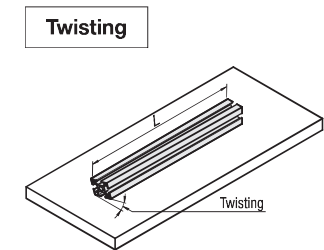

Reference: Tolerance of Outer Dimension (JIS)

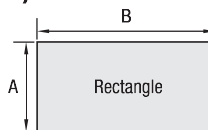
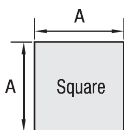

Unit: mm

Outer Dimension Tolerance (JIS)	A Dimension
NFS5-2020	±0.41
NFS5-4040	±0.54
NEFS6-3030	
NFS6-6060	±0.86
NEFS8-4040	±0.54
NEFS8-8080	±0.86
NEFS8-4545	±0.60
NFS8-9090	±0.86

Outer Dimension Tolerance (JIS)	A Dimension	B Dimension
NFS5-2040	±0.41	±0.54
NEFS6-3060	±0.54	±0.86
NEFS8-4080		
NEFS8-4590	±0.60	

*MISUMI Aluminum Extrusions are within JIS dimension tolerance above.

Mechanical Properties of Aluminum Extrusions

Series	JIS Standard (Reference)
	NFS Series
Material (JIS Symbol)	A6063S-T5
Tensile Strength (N/mm ²)	155 or more
Proof Stress (N/mm ²)	110 or more
Longitudinal Elastic Modulus (N/mm ²)	69972
Brinell Hardness (HB)	88
Surface Treatment	Anodize 9μm or more

Aluminum Extrusion Frame Assembly

Prior to Beginning

1. Provide a large and flat work space for the assembly.
2. Sort the extrusions into parts and sizes.
3. Count and confirm the qty. of the nuts to be pre-inserted.

*Insert any Pre Assy. Nuts needed at this point if mounting a top plate and/or covers. This assy. example also shows installation of Plate Type Adjusters and Casters.

Assembly of Single Joint Connected Type.

1 Bottom Frame Assy.

- (1) Begin assembling with the bottom extrusion.
- (2) Center joint is connected with Pre Assy. Ins. Double Joints.
- (3) Insert the nuts prior to assembly.

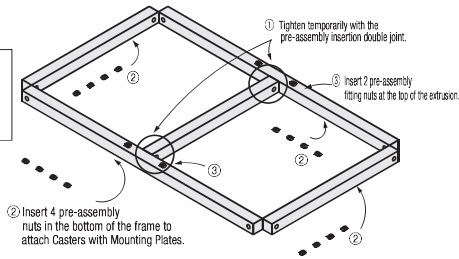

* Do not forget to insert the nuts.

2 Mount the posts.

Connect the corners with Single Joints.

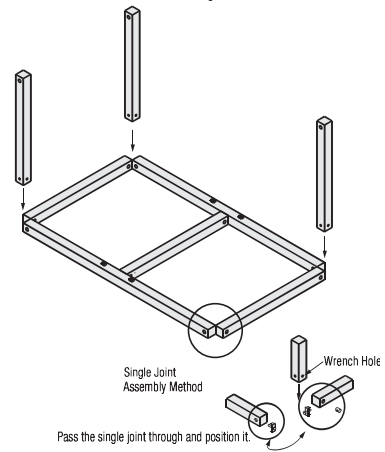

3 Mount the middle posts.

Connect the middle extrusions with Pre Assy. Ins. Double Joints.

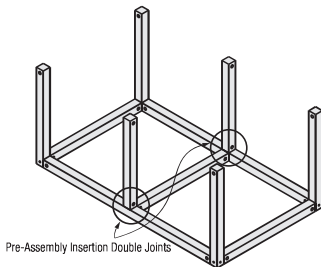

4 Top Frame Assy. (1)

Pre-install Single Joints on the ends of four posts.

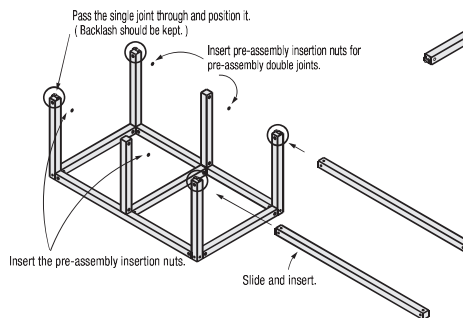

5 Top Frame Assy. (2)

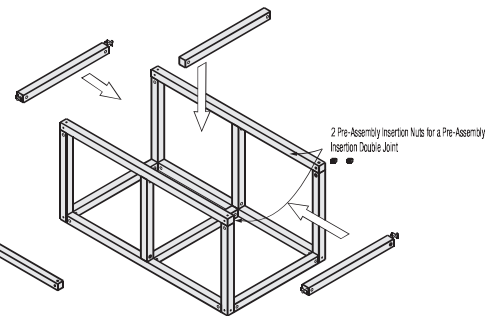

6 Adjuster and Caster Mounting

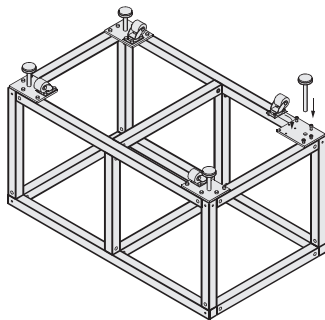

Invert the unit and mount the adjusters and casters. (Adjusters and Casters are sold separately.)

7 Final Tightening

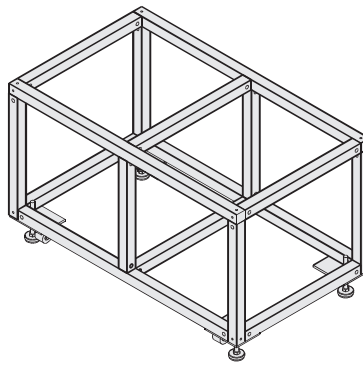

Fully tighten while adjusting the extrusion positions.

8 Surface Cleaning

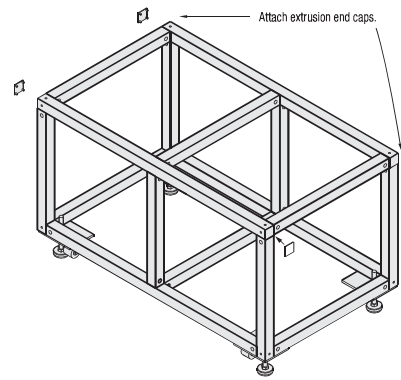





Wipe clean the surfaces with alcohol, etc. after the assembly work.

It's all about TIME

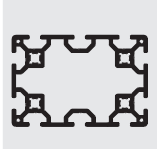
N-Series 4 โมเดล สามารถเลือกความยาวได้ตามต้องการ พร้อมจัดส่ง

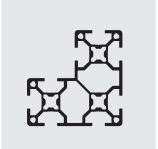
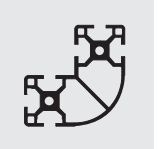
4 โมเดล ยอดนิยมทั้ง NEFS, NFS, NFSL, GNFS

Extrusion Type	    
	Square Shape Rectangle Shape R Shape L Shape L/R Shape
Extrusion Size (mm)	 $d = 20 - 100 \text{ mm}$ $w = 20 - 200 \text{ mm}$
Length (mm)	50 - 4000 เลือกความยาวเพิ่มขึ้นได้ทีละ 0.5 mm

ข้อมูลเพิ่มเติมที่เว็บไซต์ <http://th.misumi-ec.com>

- เช็คราคา/วันจัดส่ง
- สั่งซื้อสินค้าออนไลน์
- ทาวน์โพลด CAD
- สอบถามสเปค/ข้อมูลเทคนิค

MISUMI (THAILAND) CO., LTD.

300/24 Moo. 1, Eastern Seaboard Industrial Soi 5,
T.Tasith, A.Pluakdaeng, Rayong 21140
TEL : 033-684-730
Email : cs@misumi.co.th