

OIL-FREE SLIDE PLATES

— COPPER ALLOY 10mm TYPE · 2 BOLT HOLES / 4 BOLT HOLES —

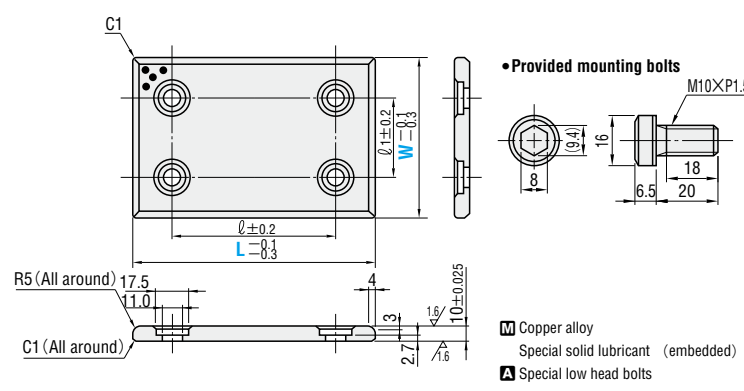
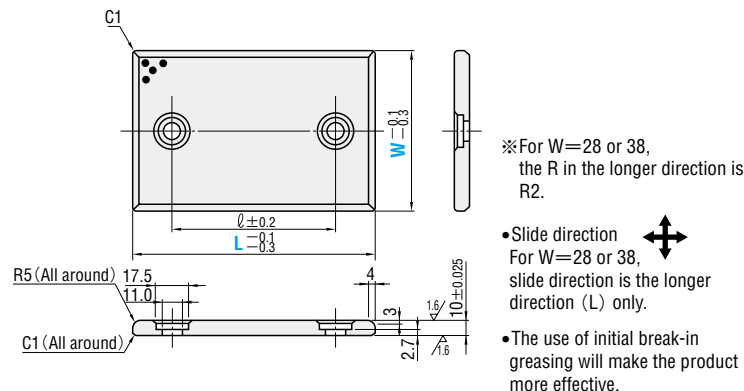

ℓ	Catalog No.	W	L
45	— 2 bolt holes — STW	28	75
50			100
75			125
100			150
150			200
45		38	75
50			100
75			125
100			150
150			200
45	48	75	
50		100	
75		125	
100		150	
150		200	
25	58	75	
50		100	
75		125	
100		150	
150		200	
25	75	75	
50		100	
75		125	
100		150	
150		200	
50	— 2 bolt holes — STWT	100	100
75			125
100			150
150			200
200			250
100		125	150
150			200
200			250
100			150
150			200

ℓ	ℓ ₁	Catalog No.	W	L		
50	50	— 4 bolt holes — STW	100	100		
75				125		
100				150		
150				200		
200				250		
100	50	125	150	200		
150				250		
200				300		
100				100	150	200
150						250
200	300					

Order Catalog No. W L

STW 75 — 100
STWT 100 — 200

Days to Ship **Quotation**

Price **Quotation**

■ Shims for oil-free slide plates P.1142

OIL-FREE SLIDE PLATES

— SINTERED ALLOY 20mm TYPE · 2 BOLT HOLES / 4 BOLT HOLES —

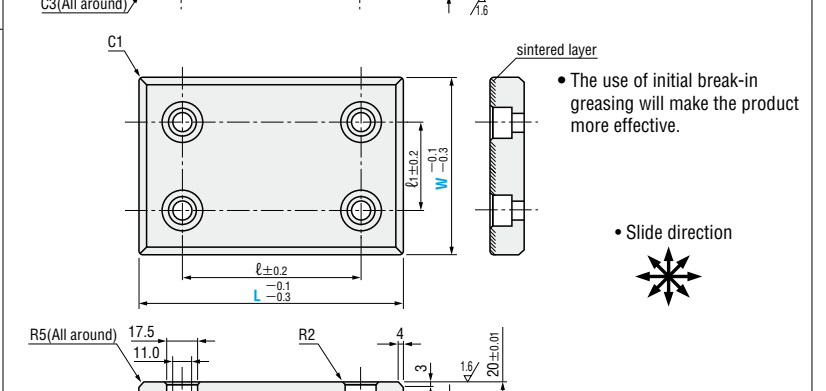
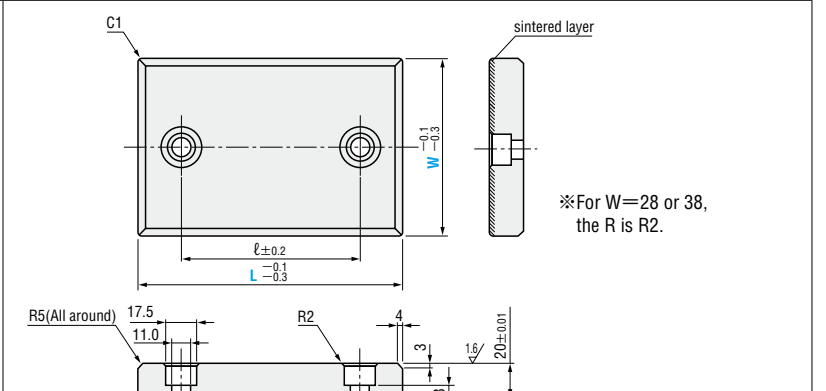

ℓ	Catalog No.	W	L
45	— 2 bolt holes — SEZ	28	75
50			100
75			125
100			150
150			200
100*		38	75
45			100
50			125
75			150
100			200
45	48	75	
50		100	
75		125	
100		150	
150		200	
25	58	75	
50		100	
75		125	
100		150	
150		200	
25	75	75	
50		100	
75		125	
100		150	
150		200	
50	— 2 bolt holes — SEZT	100	100
75			125
100			150
150			200
200			250
100		125	150
150			200
200			250
100			150
150			200
100	150	150	
150		200	
200		250	
100		150	
150		200	

ℓ	ℓ ₁	Catalog No.	W	L		
50	50	— 4 bolt holes — SEZ	100	100		
75				125		
100				150		
150				200		
200				250		
100	50	125	150	200		
150				250		
200				300		
100				100	150	200
150						250
200	300					

Order Catalog No. W L

SEZ 75 — 125

Days to Ship **Quotation**

Price **Quotation**

ℓ with mark "*" is different from that of copper alloy slide plate.