

T SHAPE STEEL / ALUMINUM FLIP COMPONENTS -SMALL TYPE-

T Shape Steel / Aluminum Push knob type

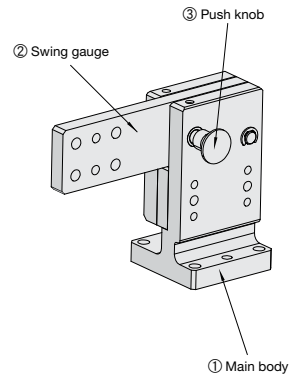

Code	Material	Left / Right	Surface Treatment
TSCLC	S45C	L	Nickel coating
TSCRC		R	
TALC	6063	L	Anodizing coating
TARC		R	

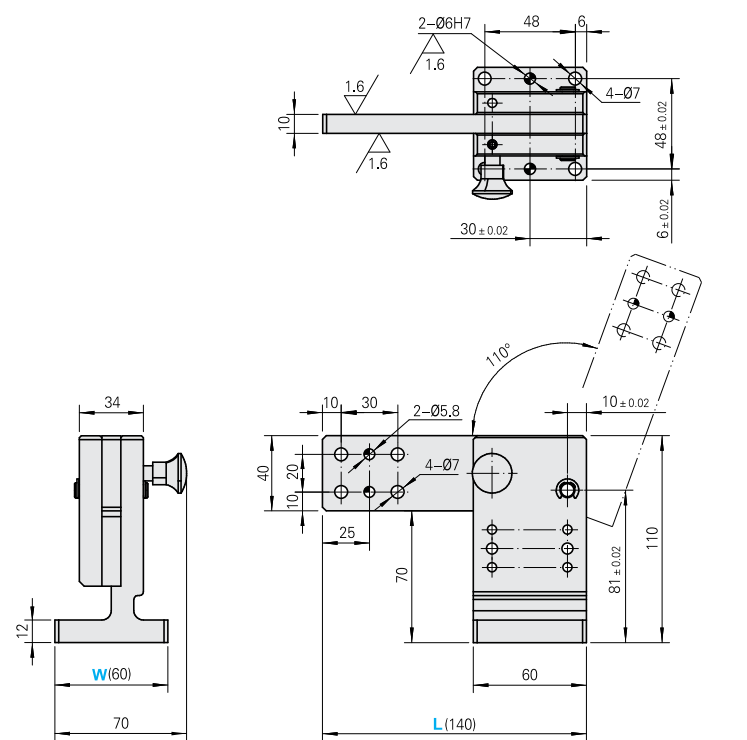

The above drawings are from Left side view and symmetric from Right side view

T Shape Steel / Aluminum Lever knob type

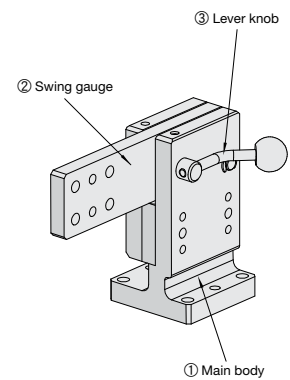

Code	Material	Left / Right	Surface Treatment
TSCLY	S45C	L	Nickel coating
TSCRY		R	
TALY	6063	L	Anodizing coating
TARY		R	

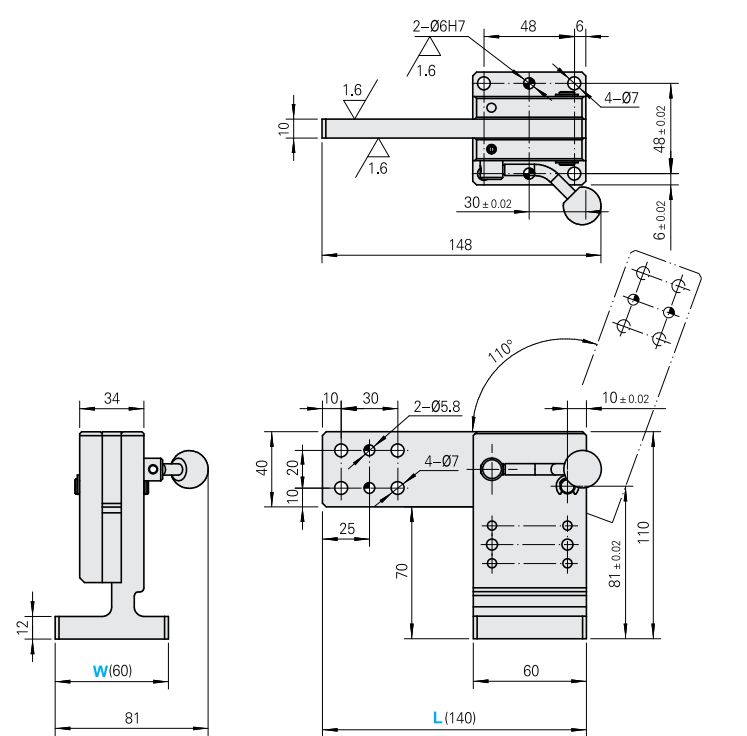

The above drawings are from Left side view and symmetric from Right side view

Material	Left / Right L/R	Catalog No.			Length (L)	Surface Treatment
		Type	Locking type	Width (W)		
Steel	L	TSCCL	C	60	140	Nickel coating
	R	TSCRC	Y			
Aluminum	L	TAL	C	60	140	Anodizing coating
	R	TAR	Y			

Order Catalog No. — L
TSCLY 60 — 140

Delivery **Quotation**

Alterations

Alterations	Code	Spec.
No hole for swing gauge	NBB	No hole for swing gauge (No heat treatment)
Change length for swing gauge	LC	Possible alteration length 100 < LC < 140 (1mm Increment)

■ Base Support for Steel T Shape Flip Component



I Shape Support GZSC60
P.33

■ Base Support for Aluminum T Shape Flip Component



Base Support XCDZA60
P.36



Aluminum Frame Support XCA60
P.35