

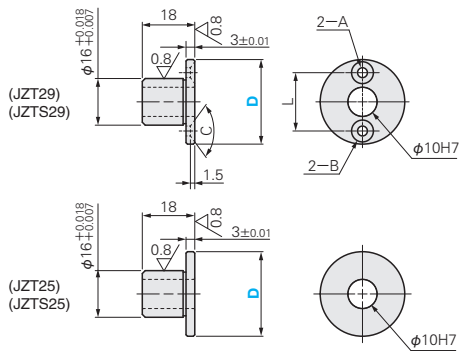

基準ブッシュ/角型基準ブロック

# CENTERING BUSHINGS / SQUARE CENTERING BLOCKS

Centering Bushing

Type	Material	Hardness
JZT	SUS420J2	50-55HRC
JZTS	SUS304	—

Catalog No.		L	A	B	C
Type	D				
JZT	25	(No Screw Hole)			
JZTS	29	20	3.4	7.5	108°

Order

Delivery **Quotation**

Square Shape Centering Block

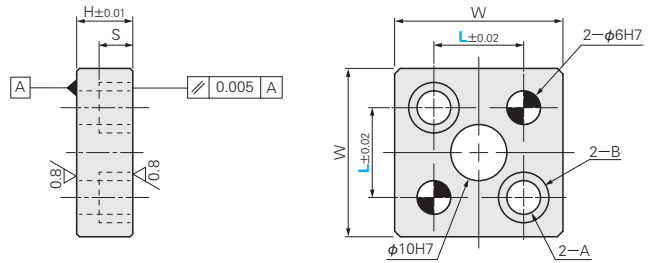
Type	Material	Hardness
JBZ	SUS420J2	50-55HRC
JBZS	SUS304	—

Catalog No.		W	H	A	B	S
Type	L					
JBZ	16	30	10	6	9	6
JBZS	18	30	10	6	9	6
	24	40	20	8	12	15

Order

Alterations  (C) — C

Delivery **Quotation**

Alterations	Code	Spec.
Change of chamfer	C	Chamfer for the locating pin hole is changed to C5.

OTHER COMPONENTS FOR CHECKING FIXTURE