

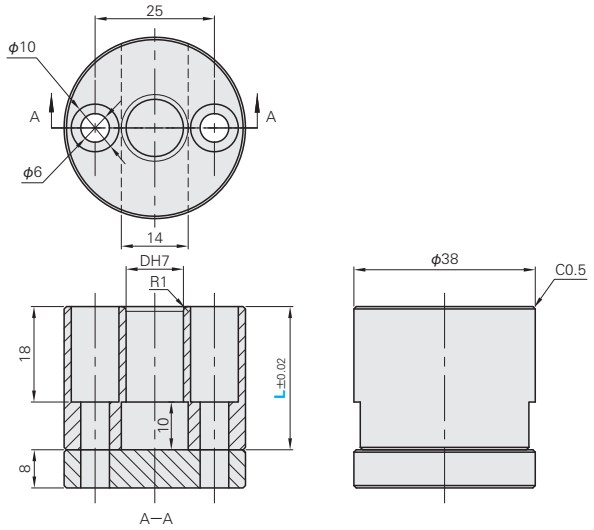

Gauge Calibration Assembly



**XBZJ**



No.	Name	Quantity	M Material	S Surface Treatment	H Hardness
①	Gauge Calibration Block	1	SUJ2	Hard Chrome	58-62HRC
②	Gauge Calibration Block Cover	1	S45C	Surface Hardening / Hard Chrome	55HRC~

Catalog No.		L
Type	No.	
<b>XBZJ</b>	1	
	2	30 40 50 70
	3	

Catalog No.	D
<b>XBZJ 1</b>	$\phi 9.55$
<b>XBZJ 2</b>	$\phi 10.00$
<b>XBZJ 3</b>	$\phi 12.00$



Order

Catalog No. — L  
**XBZJ 1 — 30**



Delivery

**Quotation**

INSPECTION AND LOCATING COMPONENTS

Dial Gauge

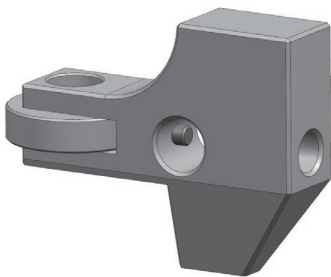

**DBZ**

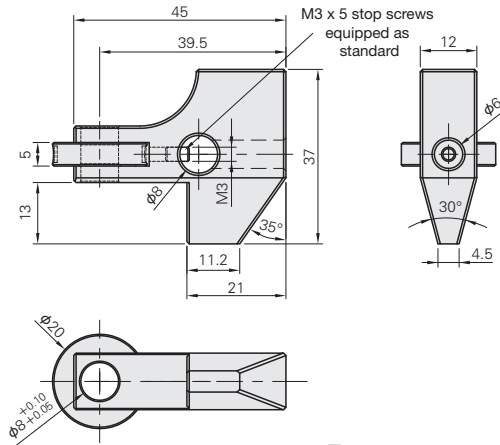

M Material S45C  
S Surface Treatment Nickel coating

Catalog No.	
Type	No.
<b>DBZ</b>	1



Order

Catalog No.  
**DBZ 1**



Delivery

**Quotation**