

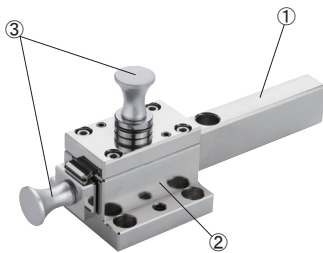

スライドユニット  
**SLIDE UNITS**

UNITS AND RELATED COMPONENTS

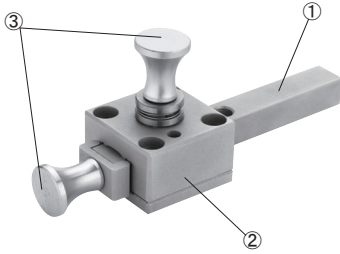

No.	Name	Material	Surface Treatment
①	Slider	S45C	Nickel coating
②	Main body	S45C	Nickel coating
③	Handle	A6061	Anodizing coating

**USCHC40**

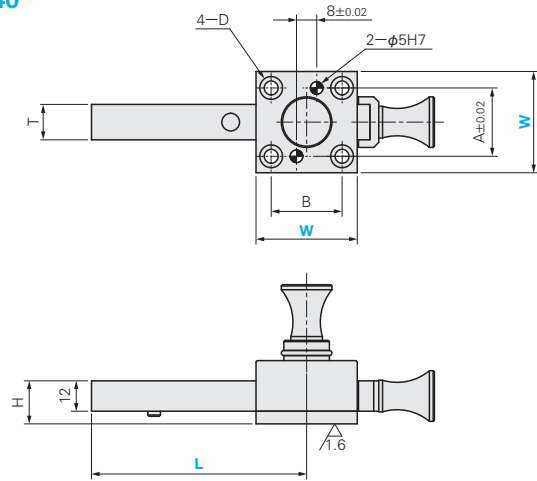

**USCHC60 · 80**

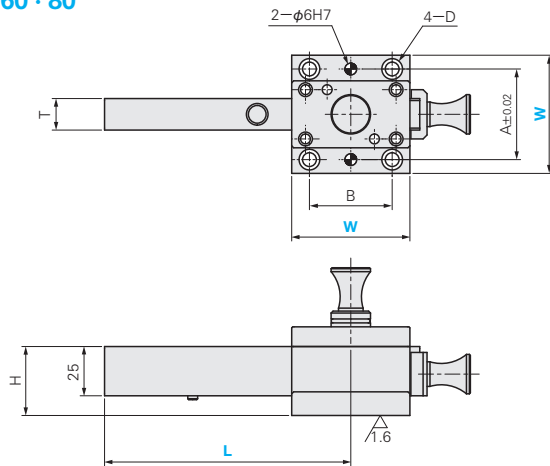

Catalog No.		L	H	T	A	B	D
Type	W						
<b>USCHC</b>	40	85	17	14	27	28	5.5
	60	125	35	16	46	42	7
	80	135	36	20	62	45	9



Order

Catalog No. — L  
**USCHC 60** — 125



Delivery

**Quotation**

■Optional supports: **GZAG**(P.54), **LZAG**(P.53)  
**GZSC**(P.51), **LZSC**(P.50)