



スライドユニット -T型スイングアーム-

SLIDE UNITS

-T SHAPE SWING ARM-

UNITS AND RELATED COMPONENTS

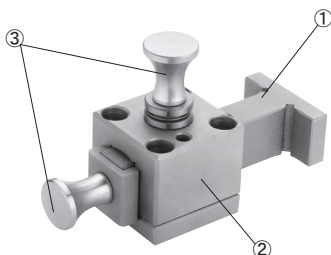

WSCHC40

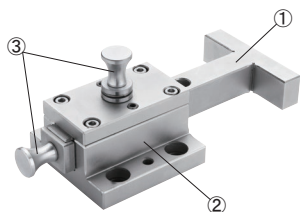
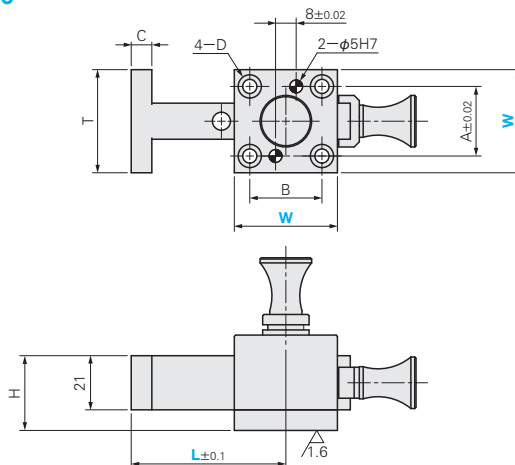

WSCHC60・80

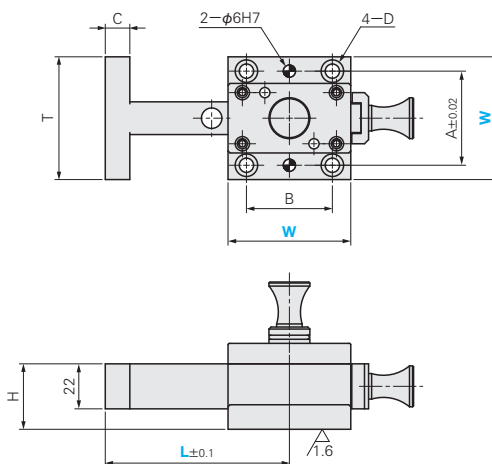

No.	Name	M Material	S Surface Treatment
①	Slider	S45C	Nickel coating
②	Main body	S45C	Nickel coating
③	Handle	A6061	Anodizing coating

Catalog No.		L	H	T	A	B	C	D
Type	W							
WSCHC	40	60	29	40	27	28	8	5.5
		80						
	60	90	32	60	46	42	12	7
		120						
	80	120	36	80	62	45	15	9
		160						



Order

Catalog No. — L
WSCHC 60 — 90



Delivery

Quotation

■Optional supports: GZAG(P.54), LZAG(P.53)
GZSC(P.51), LZSC(P.50)