

SBDC4



Input	Input point count (number of mounted devices) *Sensors, actuators, etc.	Up to 4	a contact (NO) / b contact (NC) switchable Relay output or NPN open collector output
	Anti-chattering timer	Individual	1 sec, 10 sec, 1 min, 10 min × timer knob
Output	External output point count	Individual (up to 4) Batch	a contact a contact (NO) / b contact (NC) switchable
	Buzzer	1	Individual ON/OFF switchable 100dBA (@10 cm)
	Buzzer stop timer	Batch	6 sec, 60 sec, 6 min, 60 min × timer knob
	Warning light (also used as buzzer stop switch)	1	Batch lighting (red only)
	Identification light	4	
	DC power output	DC 24 V (4 service power supplies) *Approx. 24 W (21.6 W)	
Input power	Power supply voltage	Single-phase AC100V/200V	
	Voltage allowable range	AC85-265V	
	Frequency	50/60 Hz	
	Connector	3P male NJC-203-RM	
Dimensions (mm)		200×200×100	
Operating temperature range		-5~60°C	
Mass (kg)		1.8 kg	
Accessories		Instruction manual	

- ⓘ Power cables and sensors other than the main body are sold separately.
- ⓘ There is no power ON/OFF switch on the main body. It will turn on when the power cable is connected, eliminating problems caused by forgetting to turn on.

- ⓘ The value in () for "*" indicates a 100 VAC power supply.
- ⓘ The anti-chattering timer is at half-point where the timer knob is at the 6 o'clock position.
Example: 10 min × timer knob at 6 o'clock position = 5 min
- ⓘ The buzzer stop timer is at half-point where the timer knob is at the 6 o'clock position.
Example: 60 min × timer knob at 3 o'clock position = 15 min

■ Body

Part Number	Unit Price
	1~6 pcs
SBDC4	Quotation

■ Power cable For 100 VAC

Part Number	Cable length	Conductor cross-sectional area	No. of core wire	Terminal		Unit Price
				Outlet plug	Metal connector	
BC-AC100-1	1 m	0.75 mm ²	3	Flat 2P + ground pin (A type) *With 3P-2P conversion adapter	3P female *NJC-203-PF used	Quotation
BC-AC100-3	3 m					
BC-AC100-5	5 m					
BC-AC100-10	10 m					



Order

Part Number
BC-AC100-5



Days to Ship

[Quotation](#)



Price

[Quotation](#)

■ Power cable For 200 VAC

Part Number	Cable length	Conductor cross-sectional area	No. of core wire	Terminal		Unit Price
				Round crimp terminal	Metal connector	
BC-AC200-1	1 m	0.75 mm ²	3	M5	3P female *NJC-203-PF used	Quotation
BC-AC200-3	3 m					
BC-AC200-5	5 m					
BC-AC200-10	10 m					

ALARM OUTPUT BOX - CIRCUIT DIAGRAM

■ Circuit Diagram

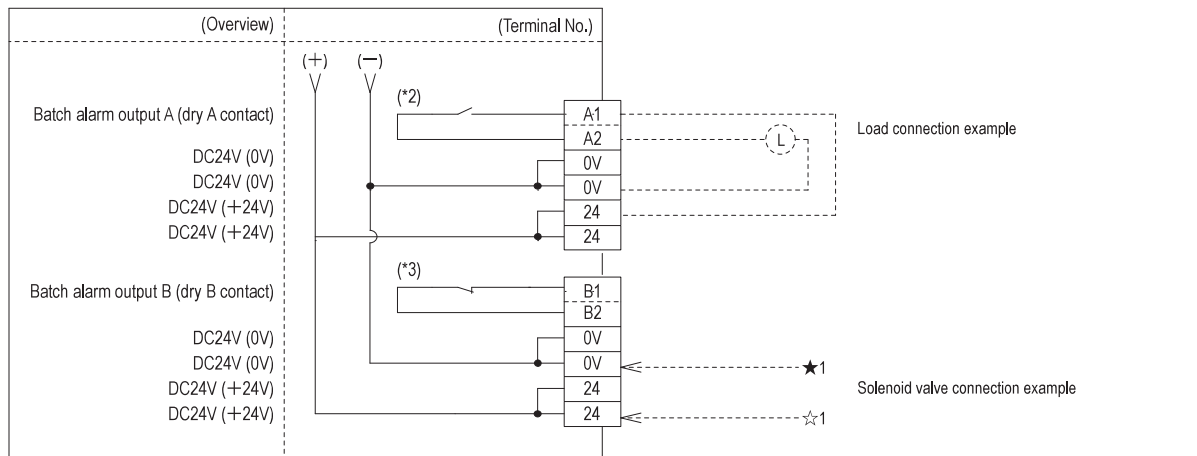
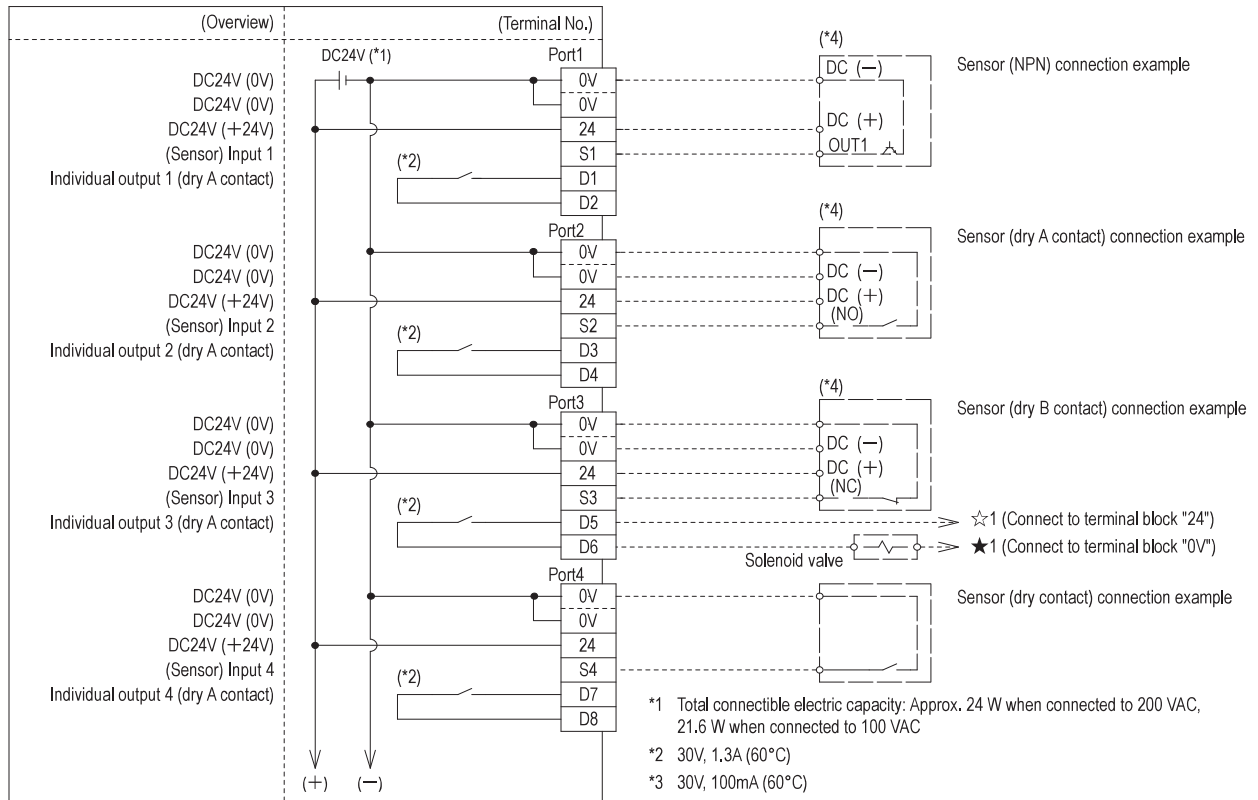

*4 Sensor type selection switch (SW12, SW22, SW32, SW42)

