



# Flat Belt Conveyor GV Series Full Belt Type

## Center Drive, 2-Slot Frame (Pulley Dia. 30mm)

**Conveyor Resource Site:**  
<http://www.misumiusa.com/conveyor/>  
 The above site can be used to search for conveyor components and their maintenance parts.

Features: The drive section is designed to be as compact as possible. Center drive conveyor with a full-width belt that enables almost the entire surface to be used for transporting. The construction allows for easy belt replacement.



### GVFN

- Each slot has 4 nuts inserted.
- The dimensions in the diagram is for Belt Specification H (which has a belt thickness of 0.9mm). Note that the belt thickness varies depending on belt specifications.
- When L>1,400, it is recommended to mount on at least 2 stands.

	Frame	Motor Cover	Pulley Holder
<b>M</b> Material	Aluminum	Aluminum	Aluminum
<b>S</b> Surface Treatment	Clear Anodize	Painted	Painted

\*Taiwanese Motors are not RoHS compliant.

### 25 W Motor Type

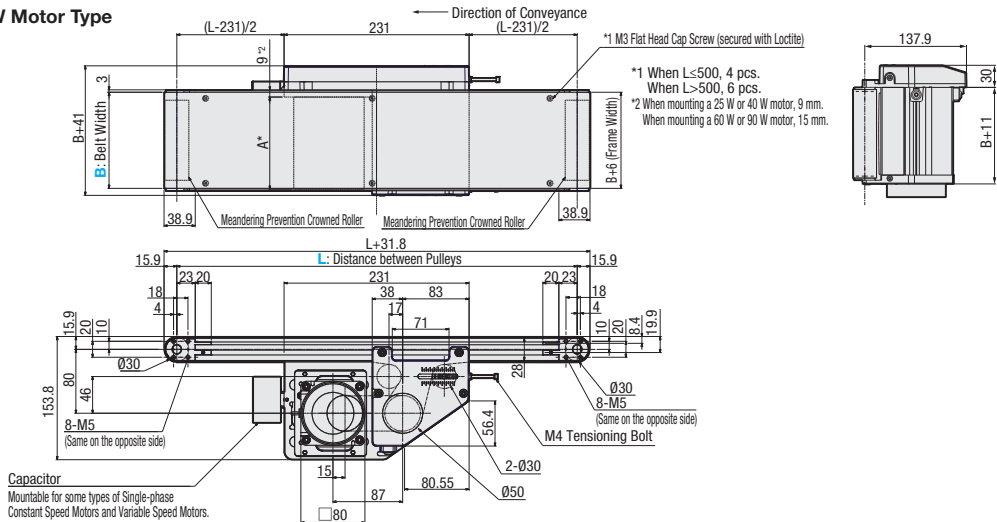

### 40, 60, 90 W Motor Type

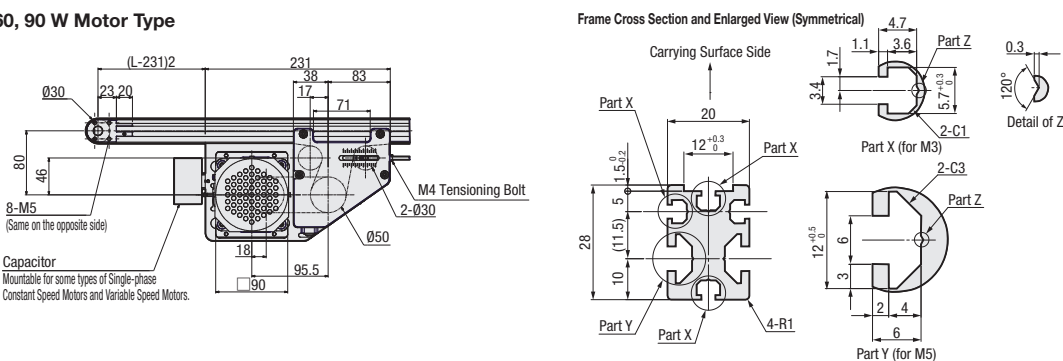

### \*A Dimension (Motor Overall Length) Details

Output (W)	Motor Specifications	Manufacturer	Reduction Ratio	A
25 W	Constant speed motor	Panasonic	5-180	115.0
		Oriental	5-18	117.0
		Taiwanese	25-180	127.5
		Oriental	5-75	129.0
		Taiwanese	90-180	136.0
	Variable speed motor	Oriental	5-18	127.0
		Taiwanese	25-180	137.5
		Oriental	5-75	139.5
		Taiwanese	90-180	146.5
		Panasonic	5-180	142.0
40 W	Constant speed motor	Panasonic	5-18	147.0
		Oriental	25-180	165.0
		Taiwanese	5-75	161.6
		Oriental	90-180	170.6
		Taiwanese	5-18	157.0
	Variable speed motor	Oriental	25-180	175.0
		Taiwanese	5-75	172.1
		Oriental	90-180	181.1
		Panasonic	5-180	180.0
		Oriental	5-180	185.0
60 W	Constant speed motor	Panasonic	5-180	182.6
		Oriental	90-180	191.6
		Taiwanese	5-180	215.0
		Oriental	5-75	194.6
		Taiwanese	90-180	203.6
	Variable speed motor	Panasonic	5-180	195.0
		Oriental	5-180	200.0
		Taiwanese	5-75	197.6
		Oriental	90-180	206.6
		Taiwanese	5-180	230.0
90 W	Constant speed motor	Panasonic	5-180	209.6
		Oriental	90-180	218.6
		Taiwanese	5-75	209.6
		Oriental	5-180	218.6
		Taiwanese	90-180	218.6
	Variable speed motor	Panasonic	5-180	218.6
		Oriental	5-180	218.6
		Taiwanese	5-75	209.6
		Oriental	90-180	218.6
		Taiwanese	90-180	218.6

### Conveying Capacity

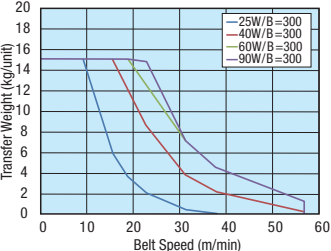

- For accumulation conveyance (only compatible with sliding belts), consider conveying capacity to be no more than 1/2 of that shown in the graph.
- Conveying capacity may vary depending on operating conditions.
- This graph shows conveying capacity when level.

### Gearhead Reduction Ratio

\*Reference Value

\*Conveyance speed reference values are based on IM (motor rotational speed 1,500 rpm [50 Hz]/1,800 rpm [60 Hz]). \*May decrease depending on load condition.

Gearhead Reduction Ratio	Belt Speed (m/min)	
	50Hz	60Hz
5	47.1	56.5
7.5	31.4	37.7
9	26.2	31.4
12.5	18.8	22.6
15	15.7	18.8
18	13.1	15.7
25	9.4	11.3
30	7.9	9.4
36	6.5	7.9
50	4.7	5.7
60	3.9	4.7
75	3.1	3.8
90	2.6	3.1
100	2.4	2.8
120	2.0	2.4
150	1.6	1.9
180	1.3	1.6

- For motor specification IM, the above conveyance speeds are constant speeds.
- For motor specification SCM, refer to the above values for the maximum speed.
- Motor specification SCM is adjustable up to (1/15) × (max. speed). The weight that can be conveyed decreases as speed decreases.

Part Number	B 10 mm Increments	L 5 mm Increments	Motor				Belt Specifications	Motor Manufacturer Selection
			Output (W)	Voltage (V)	Specifications	Gearhead Reduction Ratio		
GVFN	50~300	320~2000	25 40 60 90	TA110 TA115 TA220 TA230 (Single-phase)	IM (Constant Speed Motor)	5 7.5 9 12.5 15 18 25 30 36 50 60 75 90 100 120 150 180	H (General Purpose, Green) W (General Purpose, White) G (For Sliding, Green) S (For Sliding, White) D (For Electronic Parts Transfer, Black) F (For Food Transfer, White) O (Oil Resistant, Navy Blue) N (Non-adhesive, White) J (No Belt)	A (Panasonic Motor) B (Oriental Motor) C (Taiwanese Motor) *SCM (Variable Speed Motor) is not selectable for A. *For C, the conveyance speed may decrease by approx. 20%. R (No Motor, Gearhead)
					SCM (Variable Speed Motor)			
						SA220 SA230 (3-Phase)	IM (Constant Speed Motor)	
			NV (No Motor)	NM (No Motor)	NH (No Gearhead)			

- Connect the motor so that the belt rotates in the direction of conveyance.
- When "No motor, gearhead" is selected, the motor mounting hole pitch will vary depending on the motor output. For the dimension details, see Technical Information in our Conveyor Selection web site.
- When "No motor, gearhead" is selected, this unit will be delivered unassembled. The customer is to assemble the unit by following instructions on the included assembly procedure manual. See our Conveyor Selection site for packaging details.
- Mounting brackets for speed controllers are not included with the variable speed motor. When mounting brackets for speed controllers are required, select [SCB] as an alteration.
- Oil-resistant belts cannot be used in environments where oil adheres to the back face.
- Regardless of belt specifications, it is not recommended to use the belt while the conveyor is tilted.

Part Number	B	Available Sizes																	
		L320~400	L405~500	L505~600	L605~700	L705~800	L805~900	L905~1000	L1005~1100	L1105~1200	L1205~1300	L1305~1400	L1405~1500	L1505~1600	L1605~1700	L1705~1800	L1805~1900	L1905~2000	
GVFN	50	○	○	○	○	○	○	○	○	○	○	○	○	○	○	○	○	○	○
	60-100	○	○	○	○	○	○	○	○	○	○	○	○	○	○	○	○	○	○
	110-150	-	-	-	○	○	○	○	○	○	○	○	○	○	○	○	○	○	○
	160-200	-	-	-	-	○	○	○	○	○	○	○	○	○	○	○	○	○	○
	210-250	-	-	-	-	-	○	○	○	○	○	○	○	○	○	○	○	○	○
260-300	-	-	-	-	-	-	○	○	○	○	○	○	○	○	○	○	○	○	

Ordering Example: **GVFN - 230 - 1500 - 25 - TA220 - IM - 36 - D - A (- MP · FYA · FYB · SCB · NA · WA)**

Days to Ship [Configure Online](#)

Alterations: Specify Drive Section Position, Additional Counterbores, Brackets for Speed Controller Included, Stands (Legs)

### Conveyor weight

\*Reference values (vary depending on motor manufacturer) (kg)

Belt Width B (mm)	Distance between Pulleys L (mm)			
	500	1000	1500	2000
100	7.8	9.3	10.9	12.4
200	10.2	12.3	14.3	16.3
300	12.7	15.2	17.7	20.2

- When the motor output is 40 W, add 2.7 kg.
- When the motor output is 60 W, add 3.6 kg.
- When the motor output is 90 W, add 3.9 kg.