

U-Shaped Blocks -0.1mm Increment-

Price Reduction
Up to 8%

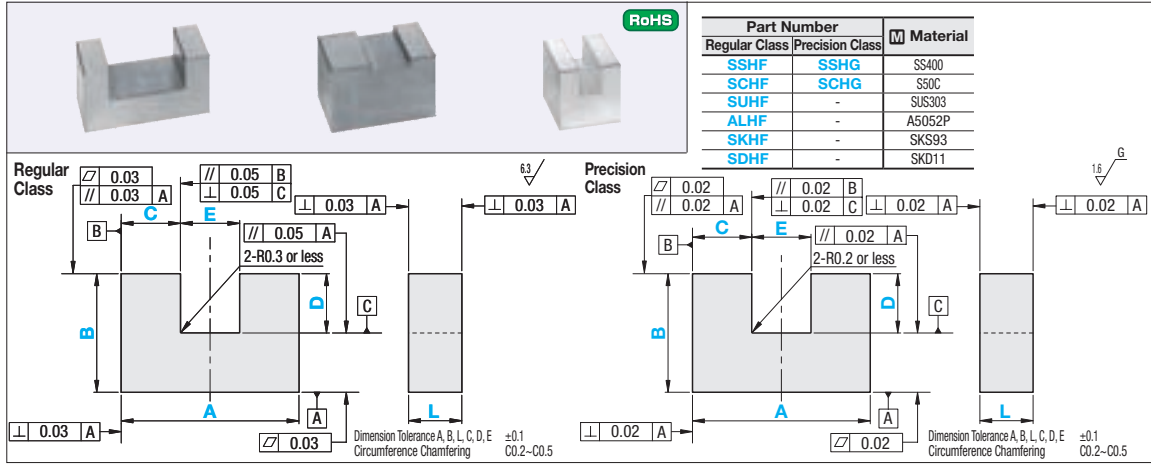

Regular Class

Part Number	0.1mm Increment				
	A	B	L	C	D
SSHF	15.0-200.0	10.0-100.0	10.0-200.0	5.0-190.0	1.0-80.0 (B-D≥5) (When L≤E, 20.0≤D)
SCHF					5.0-190.0 (C+E≥5A)
SUHF					
ALHF					
SKHF					
SDHF					

Precision Class

Part Number	0.1mm Increment				
	A	B	L	C	D
SSHG	20.0-160.0	10.0-100.0	10.0-100.0	5.0-145.0	1.0-60.0 (B-D≥3) (When 10.0≤C, 5.0≤D)
SCHG					10.0-150.0 (C+E≥5A)

Order Example Part Number - A - B - L - C - D - E
SSHF - A120.5 - B100.0 - L120.0 - C30.3 - D40.0 - E50.2

Delivery Standard Class: 7 Days Express A 370 Baht/piece P.88
Precision Class: 9 Days Express B 370 Baht/piece P.88

Price Volume Discount Rate (Round up to the Baht) P.87
Quantity Rate: 1-9 10-14 15-19
10% 10% 10% (For orders larger than indicated quantity, please request a quotation.)

Delivery Standard Class: 7 Days Express A 370 Baht/piece P.88
Precision Class: 9 Days Express B 370 Baht/piece P.88

Price Volume Discount Rate (Round up to the Baht) P.87
Quantity Rate: 1-9 10-14 15-19
10% 10% 10% (For orders larger than indicated quantity, please request a quotation.)

Common for Standard Class, V-Shaped Type, T-Shaped Type

A	B	L	10.0-30.0												30.1-50.0					50.1-60.0																								
			SS400		S50C		SUS303		A5052P		SKS93		SKD11		SS400		S50C		SUS303		A5052P		SKS93		SKD11																			
			SS400	S50C	SUS303	A5052P	SKS93	SKD11	SS400	S50C	SUS303	A5052P	SKS93	SKD11	SS400	S50C	SUS303	A5052P	SKS93	SKD11	SS400	S50C	SUS303	A5052P	SKS93	SKD11																		
10.0-60.0	10.0-60.0	10.0-60.0	942	970	2,444	2,307	1,852	2,567	1,388	1,461	3,768	2,548	2,790	3,882	1,675	1,766	4,787	3,185	3,367	4,678	2,198	2,321	6,175	3,677	4,378	6,038	2,303	2,435	6,289	4,168	4,614	6,389	2,512	2,649	6,584	4,660	7,335	6,985	2,558	2,708	6,721	4,905	5,174	7,217

Precision Class

A	L	10.0-30.0		30.1-50.0		50.1-60.0		60.1-70.0		70.1-80.0		80.1-90.0		90.1-100.0	
		SSHG	SCHG	SSHG	SCHG	SSHG	SCHG	SSHG	SCHG	SSHG	SCHG	SSHG	SCHG	SSHG	SCHG
20.0-60.0	10.0	1,666	1,716	2,116	2,175	2,353	2,426	2,667	2,749	2,690	2,903	2,908	3,167	2,967	3,226

Alterations Part Number - A - B - L - C - D - E (CKA, etc.)
SSHG - A90.0 - B100.0 - L100.0 - C20.3 - D30.0 - E30.2 - CKA

Alterations Code Dimension Tolerance (Precision Class Only)
CKA / CKB / CLK / CKC / CKD / CKE

Spec. Changes the dimension tolerance. ±0.1~±0.02
CKA for A Dimension, CKB for B Dimension, CLK for L Dimension, CKC for C Dimension, CKD for D Dimension, CKE for E Dimension

Price Adder 319

T-Shaped Blocks -0.1mm Increment-

Price Reduction
Up to 8%

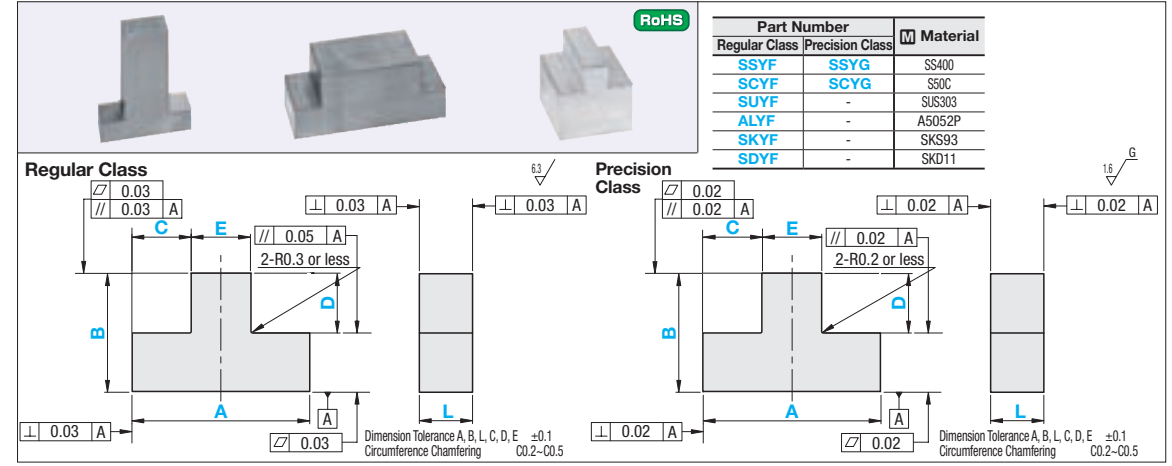

Regular Class

Part Number	0.1mm Increment				
	A	B	L	C	D
SSYF	10.0-200.0	10.0-100.0	10.0-200.0	1.0-195.0 (A-C+E)	1.0-80.0 (B-D≥5)
SUYF					5.0-190.0
SCYF					
ALYF					
SKYF					
SDYF					

Precision Class

Part Number	0.1mm Increment				
	A	B	L	C	D
SSYG	10.0-160.0	10.0-100.0	10.0-100.0	1.0-155.0	1.0-60.0 (B-D≥5)
SCYG					5.0-155.0

Order Example Part Number - A - B - L - C - D - E
SSYF - A100.0 - B100.0 - L120.0 - C30.0 - D40.0 - E50.2

Delivery Standard Class: 7 Days Express A 370 Baht/piece P.88
Precision Class: 9 Days Express B 370 Baht/piece P.88

Price Volume Discount Rate (Round up to the Baht) P.87
Quantity Rate: 1-9 10-14 15-19
10% 10% 10% (For orders larger than indicated quantity, please request a quotation.)

Delivery Standard Class: 7 Days Express A 370 Baht/piece P.88
Precision Class: 9 Days Express B 370 Baht/piece P.88

Price Volume Discount Rate (Round up to the Baht) P.87
Quantity Rate: 1-9 10-14 15-19
10% 10% 10% (For orders larger than indicated quantity, please request a quotation.)

A	B	L	60.1-70.0												70.1-80.0					80.1-90.0					90.1-100.0																
			SS400		S50C		SUS303		A5052P		SKS93		SKD11		SS400		S50C		SUS303		A5052P		SKS93		SKD11		SS400		S50C		SUS303		A5052P		SKS93		SKD11				
			SS400	S50C	SUS303	A5052P	SKS93	SKD11	SS400	S50C	SUS303	A5052P	SKS93	SKD11	SS400	S50C	SUS303	A5052P	SKS93	SKD11	SS400	S50C	SUS303	A5052P	SKS93	SKD11	SS400	S50C	SUS303	A5052P	SKS93	SKD11	SS400	S50C	SUS303	A5052P	SKS93	SKD11			
10.0-60.0	10.0-60.0	10.0-60.0	2,198	2,321	6,175	3,677	4,378	6,038	2,303	2,435	6,289	4,168	4,614	6,389	2,512	2,649	6,584	4,660	7,335	6,985	2,558	2,708	6,721	4,905	5,174	7,217	2,275	2,398	6,209	4,050	-	2,599	2,744	6,755	5,124	-	2,649	2,799	6,828	5,397	-

Precision Class

A	L	10.0-30.0		30.1-50.0		50.1-60.0		60.1-70.0		70.1-80.0		80.1-90.0		90.1-100.0	
		SSYG	SCYG	SSYG	SCYG	SSYG	SCYG	SSYG	SCYG	SSYG	SCYG	SSYG	SCYG	SSYG	SCYG
10.0-60.0	10.0	1,684	1,734	2,012	2,066	2,239	2,307	2,535	2,767	2,817	2,903	2,826	3,167	2,881	3,226

Alterations Part Number - A - B - L - C - D - E (NG)
SSYF - A90.0 - B100.0 - L100.0 - C20.3 - D30.0 - E30.2 - NG

Alterations Code Relief (T-Shaped Type only)
NG

Spec. Adds a relief groove.
C, D, E≥10
B-D≥10
A-C-E≥10

Price Adder 319