

THREE-PHASE INDUCTION MOTOR

OUTPUT	TYPE	FORM	RATING	VOLTAGE (V)	FREQ. (Hz)	SYNC. SPEED (min ⁻¹)	POLES	INS. CLASS	MASS (kg)
15HP	VTFO	KK	S1	380/415	50	3000	2	F	83
20HP	VTFO	KK	S1	380/415	50	3000	2	F	89
15HP	VTFO	KK	S1	380/415	50	1500	4	F	85
10HP	VTFO	KK	S1	380/415	50	1000	6	F	82
25HP	VTFO	KK	S1	380/415	50	3000	2	F	90
20HP	VTFO	KK	S1	380/415	50	1500	4	F	90
15HP	VTFO	KK	S1	380/415	50	1000	6	F	96

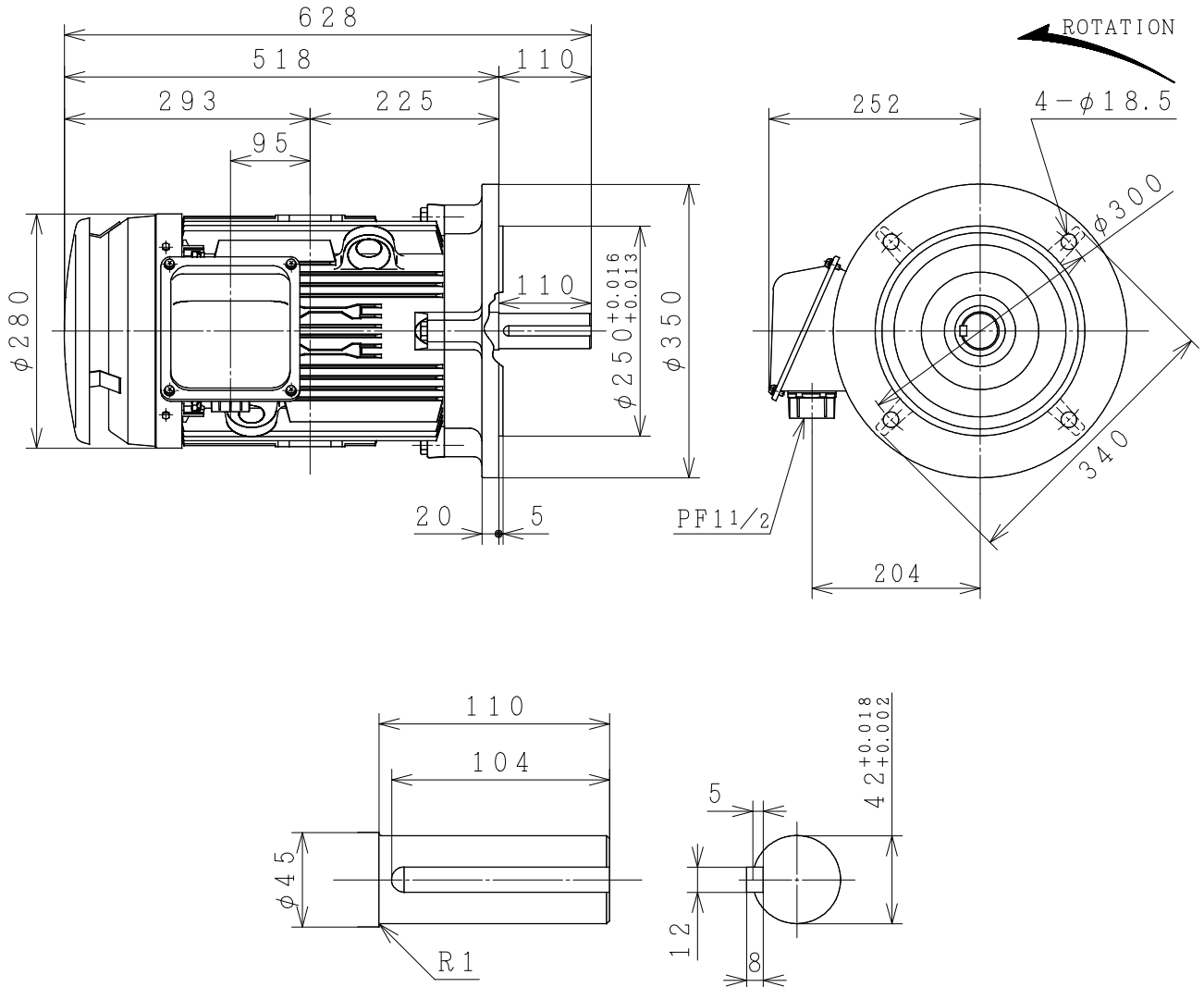

PROTECTION: IP55

PROJECTION

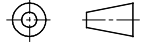

CUSTOMER			QTY.	ORDER No.	WORK No.	REV.
DWN. C. ANAN	04-06-15	DIMENSIONS	HITACHI Hitachi Industrial Technology (Thailand), Ltd.		HITT WORKS DWG. No.	SH.
CHKD. W. THAWAT	}				4HTD03116	
APPD. T. SHIMOZONO						
FRAME SIZE			VTFOF (D) - PF300 (160M. L)			

HITACHI

MANUFACTURER'S TEST REPORT OF INDUCTION MOTOR

MESSRS		ORDER No	
--------	--	----------	--

SPECIFICATION FOR MOTOR

OUT PUT(HP)	20	POLES	4	TYPE-FORM	VTFO-KK
FREQUENCY(HZ)	50/50	VOLTAGE(V)	380/415	CURRENT(A)	29.5/29.5
PHASES	3	RATING	S1	INSULATION	F
STANDARD	JEC-2137-2000	SECONDARY VOLTAGE(V)	—	SECONDARY CURRENT(A)	—
COOLING	IC411	PROTECTION	IP55	SPEED(min ⁻¹)	1450/1450

MFG No	FREQUENCY (HZ)	(1)NO-LOAD TEST			(2)LOCKED ROTOR TEST		
		VOLTAGE(V)	CURRENT(A)	INPUT(W)	VOLTAGE(V)	CURRENT(A)	INPUT(W)
	50	380	11.09	498.0	73.2	28.0	1660.0
	50	415	14.92	716.0	73.2	28.0	1660.0

(3)WINDINGS RESISTANCE (BETWEEN LINES) STATOR 115°C 0.72397 (Ω)

(4)LOAD CHARACTERISTICS

LOAD(%)	CURRENT(A)	EFFICIENCY(%)	POWER FACTOR(%)	SLIP(%)
25	12.90/16.13	86.4/82.1	51.1/39.3	0.6/0.5
50	17.17/19.23	90.3/88.2	73.5/61.3	1.3/1.1
75	22.84/23.67	90.5/89.5	82.8/73.7	2.0/1.7
100	29.43/29.06	89.4/89.2	86.6/80.3	2.8/2.4
125	36.91/35.21	87.7/88.3	88.0/83.7	3.8/3.1

(5)MAXIMUM OUT PUT(%) STARTING CURRENT(A) STARTING TORQUE(%)

228/268 194.0/212.5 261/313

(6)TEMPERATURE RISE TEST (R)-RESISTANCE METHOD

STATOR WINDINGS(K)	FRAME(K)	ROTOR WINDINGS(K)
75.0/75.0 (R)	45.0/45.0	—

(7)INSULATION RESISTANCE BY 500V MEGGER

100MΩ

(8)WITHSTAND STATOR WINDINGS TO CORE 1900V 1MIN WITHSTOOD
VOLTAGE TEST ROTOR WINDINGS TO CORE — V 1MIN WITHSTOOD

(9)CONSTRUCTION, DIMENSION, PAINTING, OTHER PARTS

SATISFACTORY

HITACHI INDUSTRIAL TECHNOLOGY (THAILAND) LTD.	CHECKED BY	T.SHIMOZONO
	DATE	09-JUNE-2015

REP.No_RP20314

Three Phase Induction Motor Characteristic Curve

Hitachi Industrial Technology(Thailand),Ltd

Power (HP)	20
Pole	4
Type-Form	TFO-KK, VTFO-KK
Voltage (V)	380
Frequency (Hz)	50
Protection	IP44, IP55

Load (%)	0	25	50	75	100	125
Current (A)	11.08	12.90	17.17	22.84	29.43	36.91
Efficiency (%)	0	86.4	90.3	90.5	89.4	87.7
Power factor (%)	6.8	51.1	73.5	82.8	86.6	88.0
Slip (%)	0	0.6	1.3	2.0	2.8	3.8

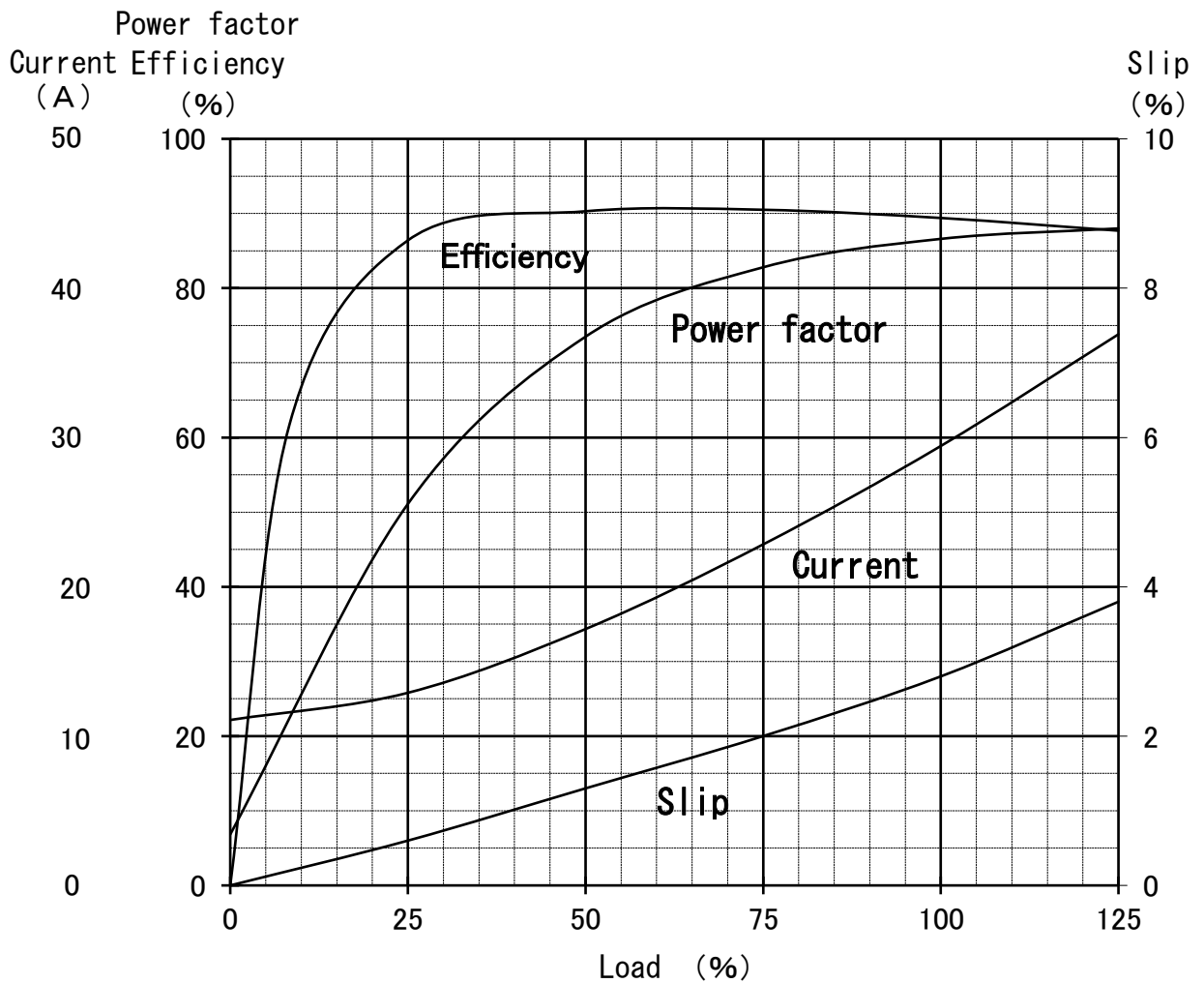

Speed-Torque, Current Curve

20HP (V) TF0-KK 4P
380/415V 50Hz
IP44/IP55

