

THREE-PHASE INDUCTION MOTOR

OUTPUT	TYPE	FORM	RATING	VOLTAGE (V)	FREQ. (Hz)	SYNC. SPEED (min ⁻¹)	POLES	INS. CLASS	MASS (kg)
15HP	VTFO	KK	S1	380/415	50	3000	2	F	83
20HP	VTFO	KK	S1	380/415	50	3000	2	F	89
15HP	VTFO	KK	S1	380/415	50	1500	4	F	85
10HP	VTFO	KK	S1	380/415	50	1000	6	F	82
25HP	VTFO	KK	S1	380/415	50	3000	2	F	90
20HP	VTFO	KK	S1	380/415	50	1500	4	F	90
15HP	VTFO	KK	S1	380/415	50	1000	6	F	96

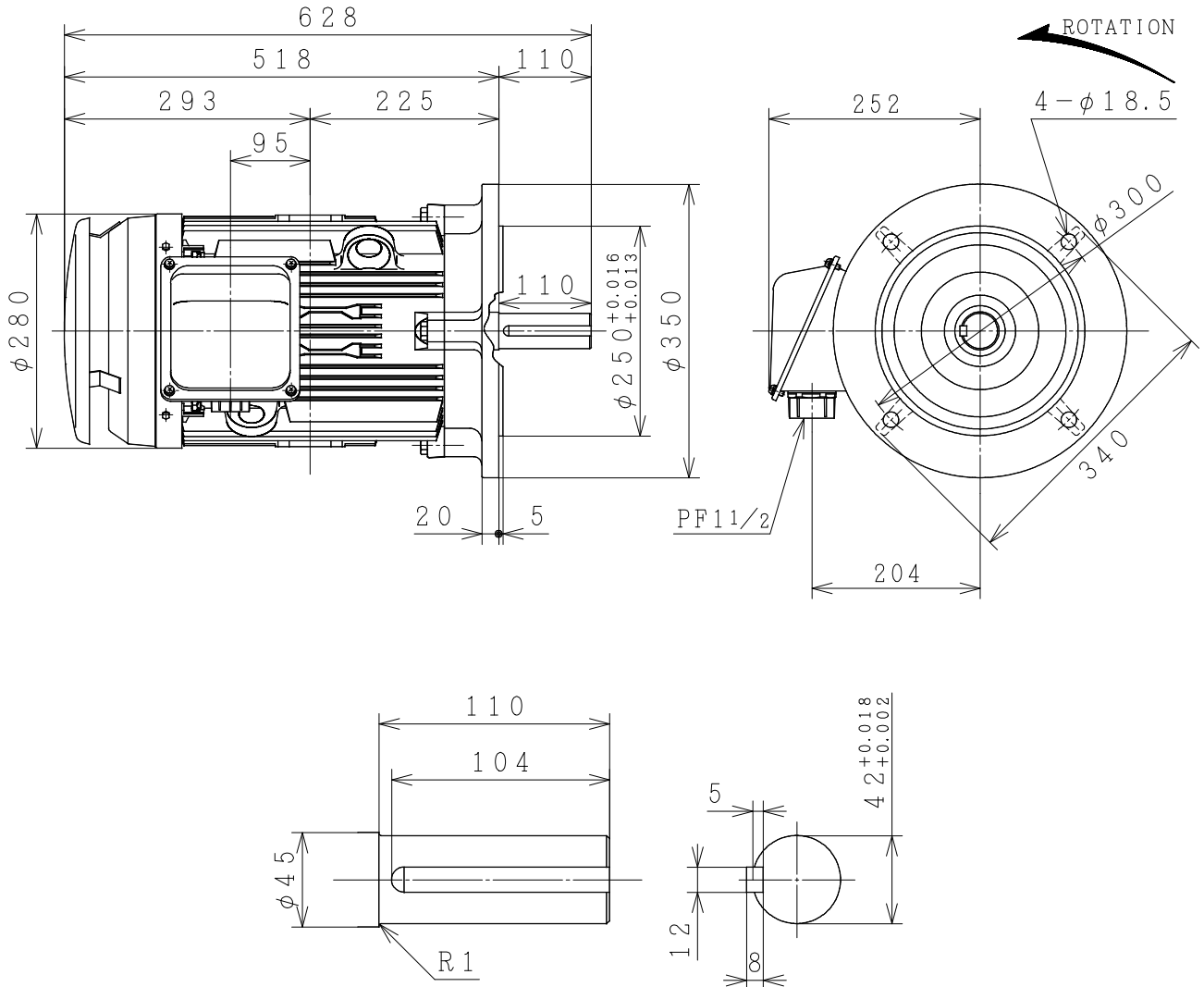

PROTECTION: IP55

PROJECTION

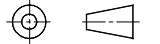

CUSTOMER			QTY.	ORDER No.	WORK No.	REV.
DWN. C. ANAN	04-06-15	§	HITACHI Hitachi Industrial Technology (Thailand), Ltd.		HITT WORKS DWG. No.	SH.
CHKD. W. THAWAT					4HTD03116	
APPD. T. SHIMOZONO						
FRAME SIZE VTFOF (D) -PF300 (160M. L)						

HITACHI

MANUFACTURER'S TEST REPORT OF INDUCTION MOTOR

MESSRS		ORDER No	
--------	--	----------	--

SPECIFICATION FOR MOTOR

OUT PUT(HP)	15	POLES	4	TYPE-FORM	VTFO-KK
FREQUENCY(HZ)	50/50	VOLTAGE(V)	380/415	CURRENT(A)	22/22
PHASES	3	RATING	S1	INSULATION	F
STANDARD	JEC-2137-2000	SECONDARY VOLTAGE(V)	—	SECONDARY CURRENT(A)	—
COOLING	IC411	PROTECTION	IP55	SPEED(min ⁻¹)	1440/1450

MFG No	FREQUENCY (HZ)	NO-LOAD TEST			LOCKED ROTOR TEST		
		VOLTAGE(V)	CURRENT(A)	INPUT(W)	VOLTAGE(V)	CURRENT(A)	INPUT(W)
	50	380	8.44	460.0	74.6	20.0	1250.0
	50	415	14.44	646.0	74.6	20.0	1250.0

(3) WINDINGS RESISTANCE (BETWEEN LINES) STATOR 115°C 1.17209(Ω)

(4) LOAD CHARACTERISTICS

LOAD(%)	CURRENT(A)	EFFICIENCY(%)	POWERFACTOR(%)	SLIP(%)
25	9.76/12.33	83.6/78.8	51.2/39.3	0.5/0.5
50	12.91/14.60	88.6/86.2	73.1/60.7	1.1/1.0
75	17.10/17.86	89.1/87.9	82.3/73.0	1.7/1.5
100	22.03/21.85	88.1/87.8	86.1/79.6	2.4/2.0
125	27.68/26.47	86.4/86.9	87.4/83.0	3.3/2.7

(5) MAXIMUM OUT PUT(%) 215/253 STARTING CURRENT(A) 133.0/145.5 STARTING TORQUE(%) 239/287

(6) TEMPERATURE RISE TEST (R)-RESISTANCE METHOD

STATOR WINDINGS(K)	FRAME(K)	ROTOR WINDINGS(K)
74.5/74.5 (R)	38.5/38.5	-

(7) INSULATION RESISTANCE BY 500V MEGGER 100MΩ

(8) WITHSTAND STATOR WINDINGS TO CORE 1900V 1MIN WITHSTOOD
VOLTAGE TEST ROTOR WINDINGS TO CORE —V 1MIN WITHSTOOD

(9) CONSTRUCTION, DIMENSION, PAINTING, OTHER PARTS SATISFACTORY

HITACHI INDUSTRIAL TECHNOLOGY (THAILAND) LTD.	CHECKED BY	C.ANAN
	DATE	06-JUNE.-2015

REP.No.RP20311

Three Phase Induction Motor Characteristic Curve

Hitachi Industrial Technology(Thailand),Ltd

Power (HP) 15
 Pole 4
 Type-Form TFO-KK, VTFO-KK
 Voltage (V) 380
 Frequency (Hz) 50
 Protection IP44, IP55

Load (%)	0	25	50	75	100	125
Current (A)	8.44	9.76	12.91	17.10	22.03	27.68
Efficiency (%)	0	83.6	88.6	89.1	88.1	86.4
Power factor (%)	10.1	51.2	73.1	82.3	86.1	87.4
Slip (%)	0	0.5	1.1	1.7	2.4	3.3

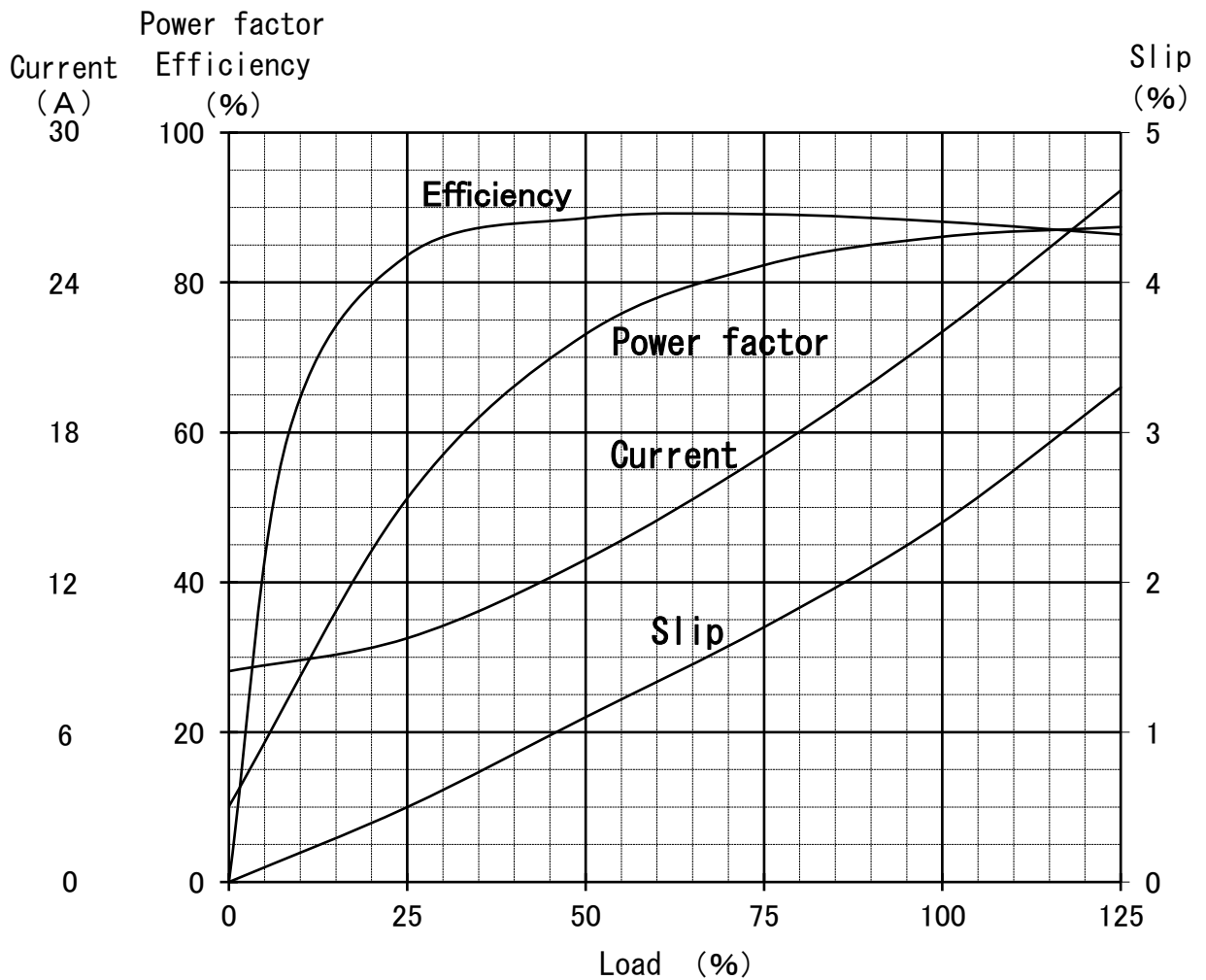

15HP (V) TF0-KK 4P
380/415V 50Hz
IP44/IP55

