

THREE-PHASE INDUCTION MOTOR

OUTPUT	TYPE	FORM	RATING	VOLTAGE (V)	FREQ. (Hz)	SYNC. SPEED (min ⁻¹)	POLES	INS. CLASS	MASS (kg)
5HP	VTFO	K	S1	220/380V	50	3000	2	F	33
5HP	VTFO	K	S1	220/380V	50	1500	4	F	35
3HP	VTFO	K	S1	220/380V	50	1000	6	F	32

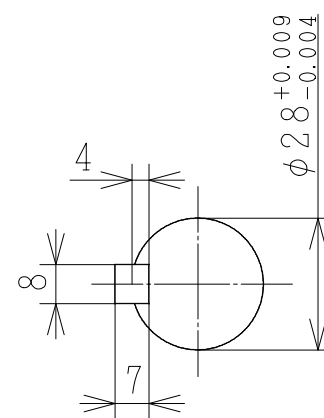

PROTECTION: IP55

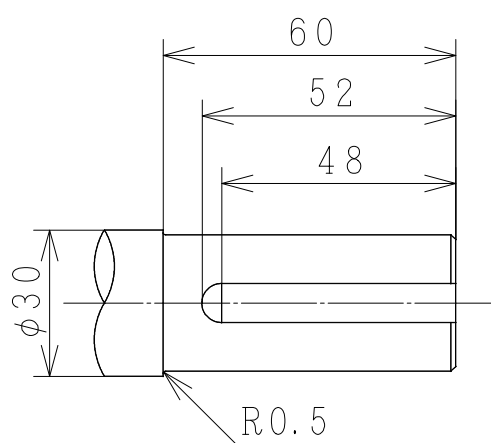
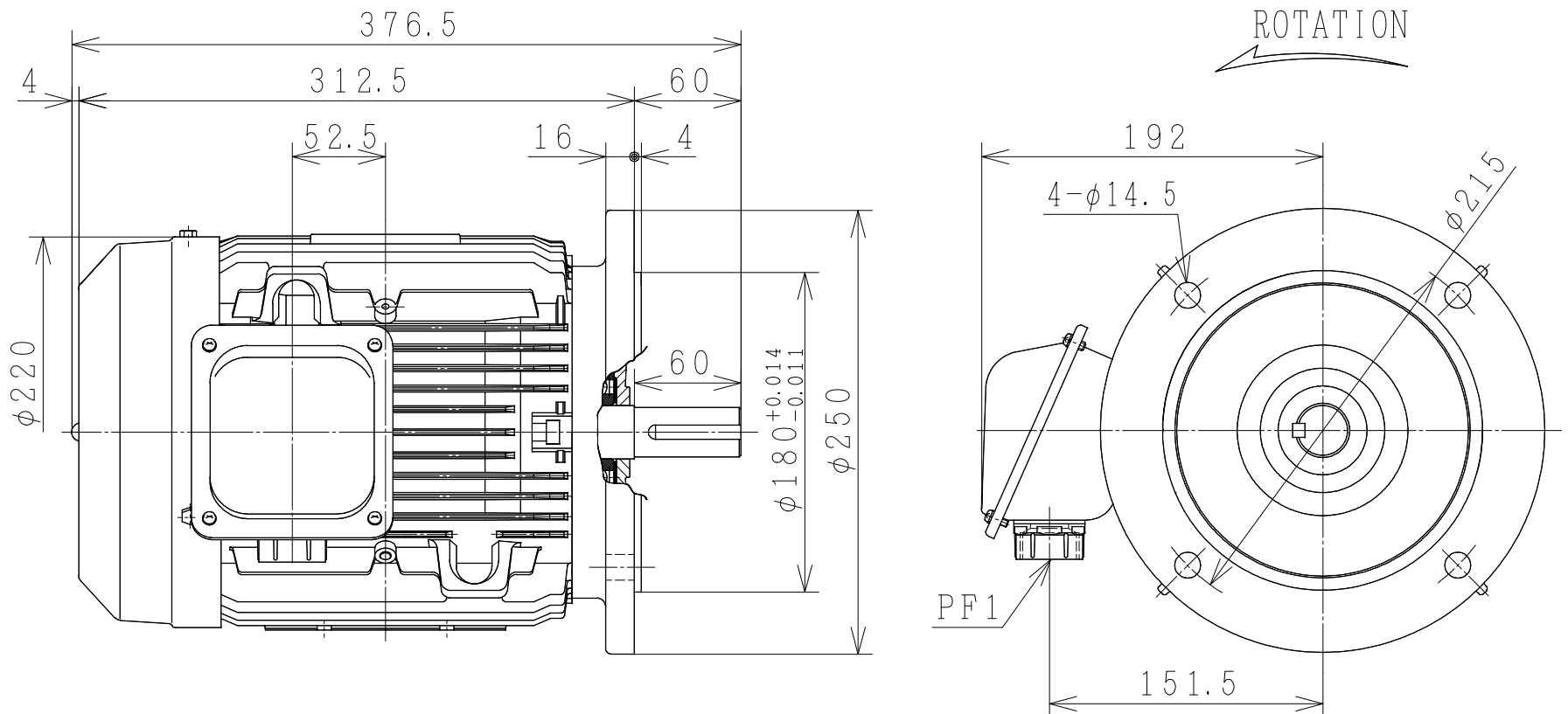
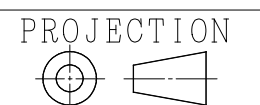

CUSTOMER			QTY.	ORDER NO.	WORK NO.	REV.		
DWN	P. Tianchai	13-Oct-2012	HITACHI Hitachi Industrial Technology (Thailand), Ltd.			SH.		
CHKD	W. THAWAT	§				DIMENSIONS		4HTD02562
APPD	M. KAMIZONO							
FRAME SIZE		VTFOD-FF215 (112M)						

HITACHI

MANUFACTURER'S TEST REPORT OF INDUCTION MOTOR

MESSRS		ORDER No	
--------	--	----------	--

SPECIFICATION FOR MOTOR

OUT PUT(HP)	5	POLES	4	TYPE-FORM	VTFO-K
FREQUENCY(HZ)	50/50	VOLTAGE(V)	220/380	CURRENT(A)	13.9/8.0
PHASES	3	RATING	S1	INSULATION	F
STANDARD	JEC-2137-2000	SECONDARY VOLTAGE(V)	—	SECONDARY CURRENT(A)	—
COOLING	IC411	PROTECTION	IP55	SPEED(min ⁻¹)	1410/1410

MFG No	FREQUENCY (HZ)	(1)NO-LOAD TEST			(2)LOCKED ROTOR TEST		
		VOLTAGE(V)	CURRENT(A)	INPUT(W)	VOLTAGE(V)	CURRENT(A)	INPUT(W)
	50	220	5.85	202.0	48.2	12.1	508.0
	50	380	3.38	202.0	83.4	7.0	508.0

(3)WINDINGS RESISTANCE (BETWEEN LINES) STATOR 115°C 1.47543/4.42630(Ω)

(4)LOAD CHARACTERISTICS

LOAD(%)	CURRENT(A)	EFFICIENCY(%)	POWER FACTOR(%)	SLIP(%)
25	6.55/3.78	79.4/79.4	46.8/46.8	1.4/1.4
50	8.30/4.79	84.7/84.7	69.3/69.3	3.0/3.0
75	10.82/6.25	84.4/84.4	80.0/80.0	4.8/4.8
100	14.00/8.09	82.0/82.0	84.8/84.8	7.0/7.0
125	18.02/10.41	78.1/78.1	86.5/86.5	9.7/9.7

(5)MAXIMUM OUT PUT(%) STARTING CURRENT(A) STARTING TORQUE(%)

161/161 79.7/46.0 219/219

(6)TEMPERATURE RISE TEST (R)-RESISTANCE METHOD

STATOR WINDINGS(K)	FRAME(K)	ROTOR WINDINGS(K)
75.0/75.0 (R)	39.5/39.5	—

(7)INSULATION RESISTANCE BY 500V MEGGER

100MΩ

(8)WITHSTAND STATOR WINDINGS TO CORE 1900V 1MIN WITHSTOOD
VOLTAGE TEST ROTOR WINDINGS TO CORE — V 1MIN WITHSTOOD

(9)CONSTRUCTION, DIMENSION, PAINTING, OTHER PARTS

SATISFACTORY

HITACHI INDUSTRIAL TECHNOLOGY (THAILAND) LTD.	CHECKED BY	T.SHIMOZONO
	DATE	25-MAY-2015

REP.No.RP20302

Three Phase Induction Motor Characteristic Curve

Hitachi Industrial Technology(Thailand),Ltd

Power (HP)	5
Pole	4
Type-Form	TFO-KK, VTFO-KK
Voltage (V)	380
Frequency (Hz)	50
Protection	IP44, IP55

Load (%)	0	25	50	75	100	125
Current (A)	3.38	3.78	4.79	6.25	8.09	10.41
Efficiency (%)	0	79.4	84.7	84.4	82.0	78.1
Power factor (%)	9.1	46.8	69.3	80.0	84.8	86.5
Slip (%)	0	1.4	3.0	4.8	7.0	9.7

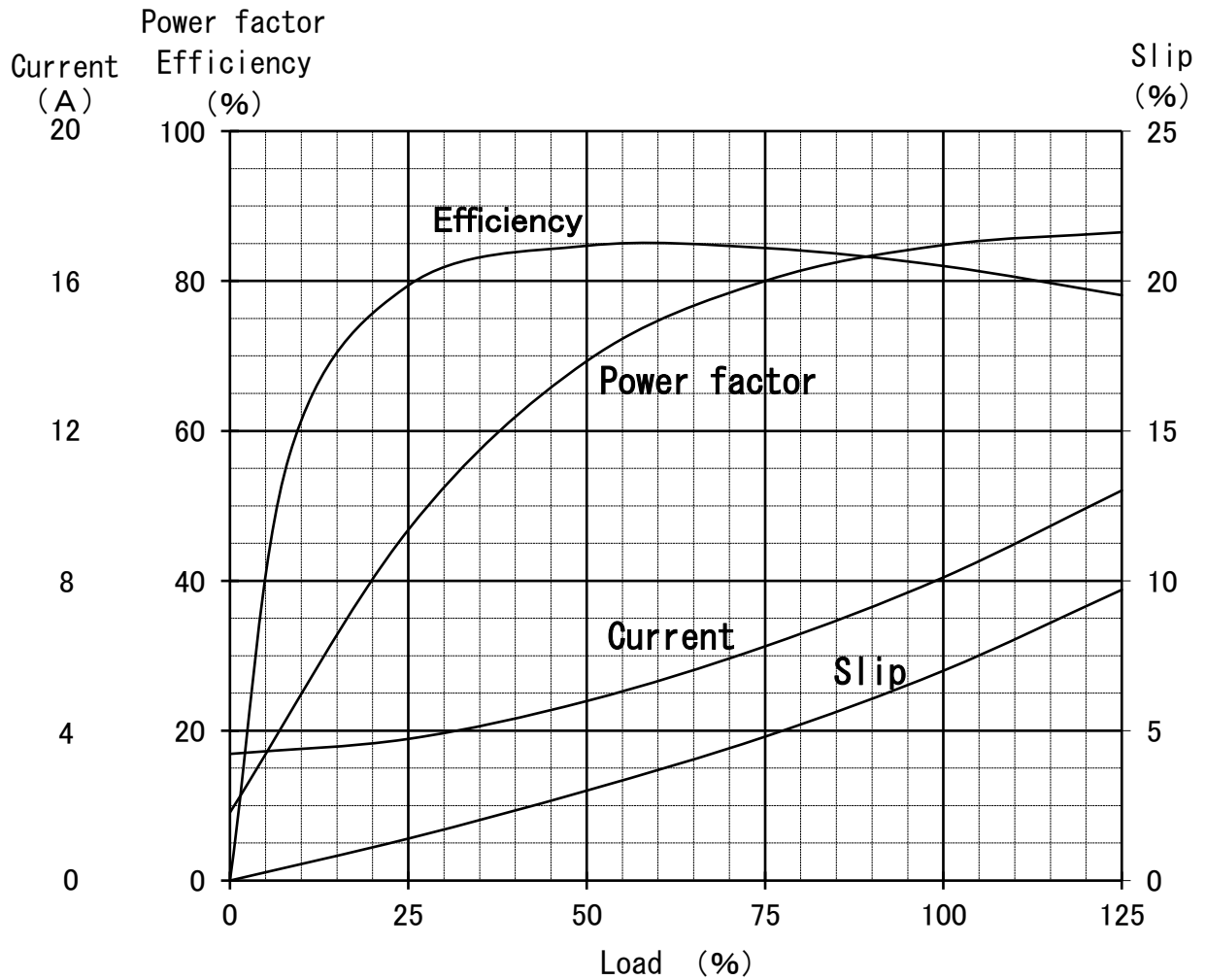

Speed-Torque, Current Curve

5HP (V) TF0-KK 4P
220/380V 50Hz
IP44/IP55

