

THREE-PHASE INDUCTION MOTOR

OUTPUT	TYPE	FORM	RATING	VOLTAGE (V)	FREQ. (Hz)	SYNC. SPEED (min ⁻¹)	POLES	INS. CLASS	MASS (kg)

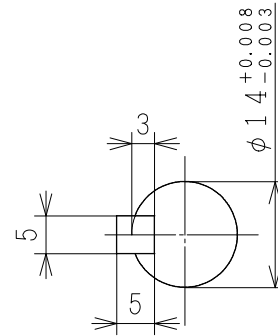
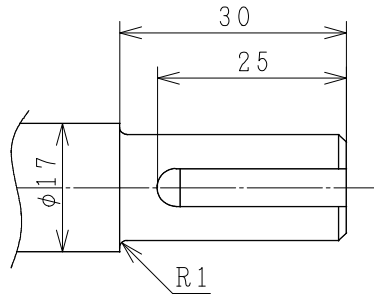
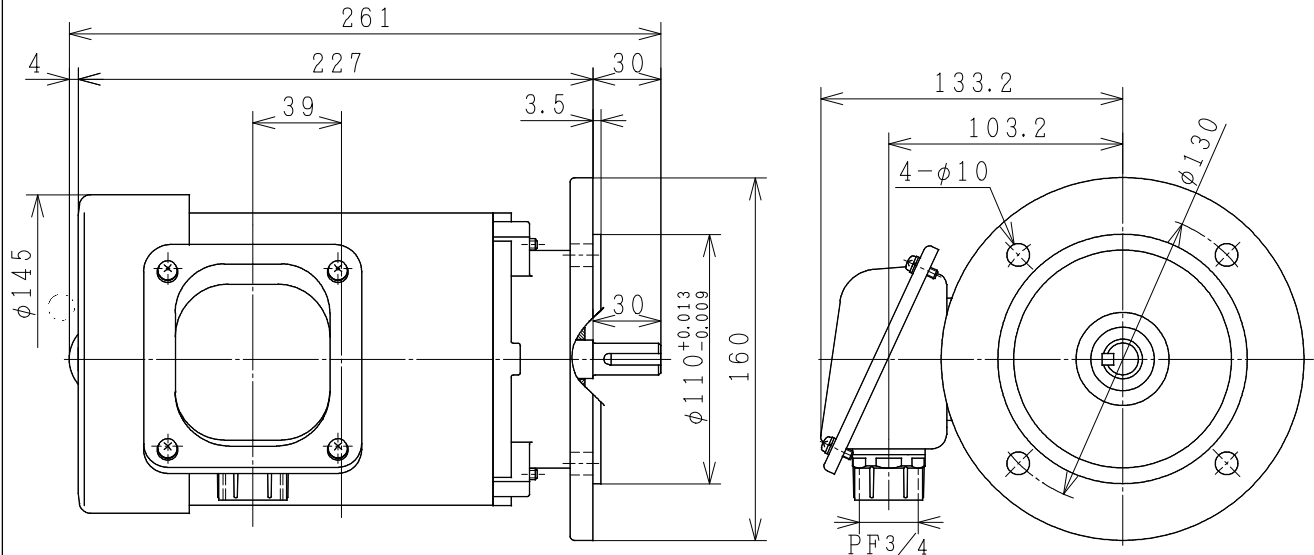

PROJECTION

CUSTOMER			QTY.	ORDER No.		WORK No.	REV.	
DWN.	P. TIANCHAI	08-01-13	<div style="display: flex; justify-content: space-around; align-items: center;"> <div style="font-size: 2em; font-weight: bold;">DIMENSIONS</div> <div style="text-align: center;"> HITACHI <small>Hitachi Industrial Technology (Thailand), Ltd.</small> </div> </div>			HITT WORKS DWG. No.		SH.
CHKD.	W. THAWAT	§				4HTD02477		
APPD.	T. SHIMOZONO							
FRAME SIZE VTFOB-FF130 (71M)								

HITACHI

MANUFACTURER'S TEST REPORT OF INDUCTION MOTOR

MESSRS		ORDER No	
--------	--	----------	--

SPECIFICATION FOR MOTOR

OUT PUT(HP)	1/2	POLES	4	TYPE-FORM	VTFO-K
FREQUENCY(HZ)	50/50	VOLTAGE(V)	220/380	CURRENT(A)	2.1/1.2
PHASES	3	RATING	S1	INSULATION	F
STANDARD	JEC-2137-2000	SECONDARY VOLTAGE(V)	—	SECONDARY CURRENT(A)	—
COOLING	IC411	PROTECTION	IP55	SPEED (min ⁻¹)	1420/1420

MFG No	FREQUENCY (HZ)	NO-LOAD TEST			LOCKED ROTOR TEST		
		VOLTAGE(V)	CURRENT(A)	INPUT(W)	VOLTAGE(V)	CURRENT(A)	INPUT(W)
	50	220	1.54	96.0	48.8	2.0	138.0
	50	380	0.87	92.0	87.0	1.2	141.0

(3) WINDINGS RESISTANCE (BETWEEN LINES) STATOR 115°C 16.12597/48.33952 (Ω)

(4) LOAD CHARACTERISTICS

LOAD(%)	CURRENT(A)	EFFICIENCY(%)	POWERFACTOR(%)	SLIP(%)
25	1.57/0.88	48.9/50.0	31.9/32.1	1.0/0.8
50	1.65/0.93	64.1/65.1	46.4/46.9	2.0/1.7
75	1.78/1.01	70.3/71.2	58.7/59.2	3.1/2.7
100	1.97/1.12	72.7/73.6	68.5/68.9	4.4/3.7
125	2.21/1.26	73.0/74.0	75.8/76.0	5.9/5.0

(5) MAXIMUM OUT PUT(%) STARTING CURRENT(A) STARTING TORQUE(%)

235/235 9.4/5.5 329/329

(6) TEMPERATURE RISE TEST (R): RESISTANCE METHOD

STATOR WINDINGS(K)	FRAME(K)	ROTOR WINDINGS(K)
71.5/71.5 (R)	47.0/47.0	—

(7) INSULATION RESISTANCE BY 500V MEGGER

100Ω

(8) WITHSTAND VOLTAGE TEST STATOR WINDINGS TO CORE 1900V 1MIN WITHSTOOD
 ROTOR WINDINGS TO CORE —V 1MIN WITHSTOOD

(9) CONSTRUCTION, DIMENSION, PAINTING, OTHER PARTS SATISFACTORY

HITACHI INDUSTRIAL TECHNOLOGY (THAILAND) LTD.	CHECKED BY	T.SHIMOZONO
	DATE	23-MAY-2015

REP.No_RP20290

Speed-Torque, Current Curve

1/2HP (V) TF0-K 4P
220/380V 50Hz
IP44/IP55

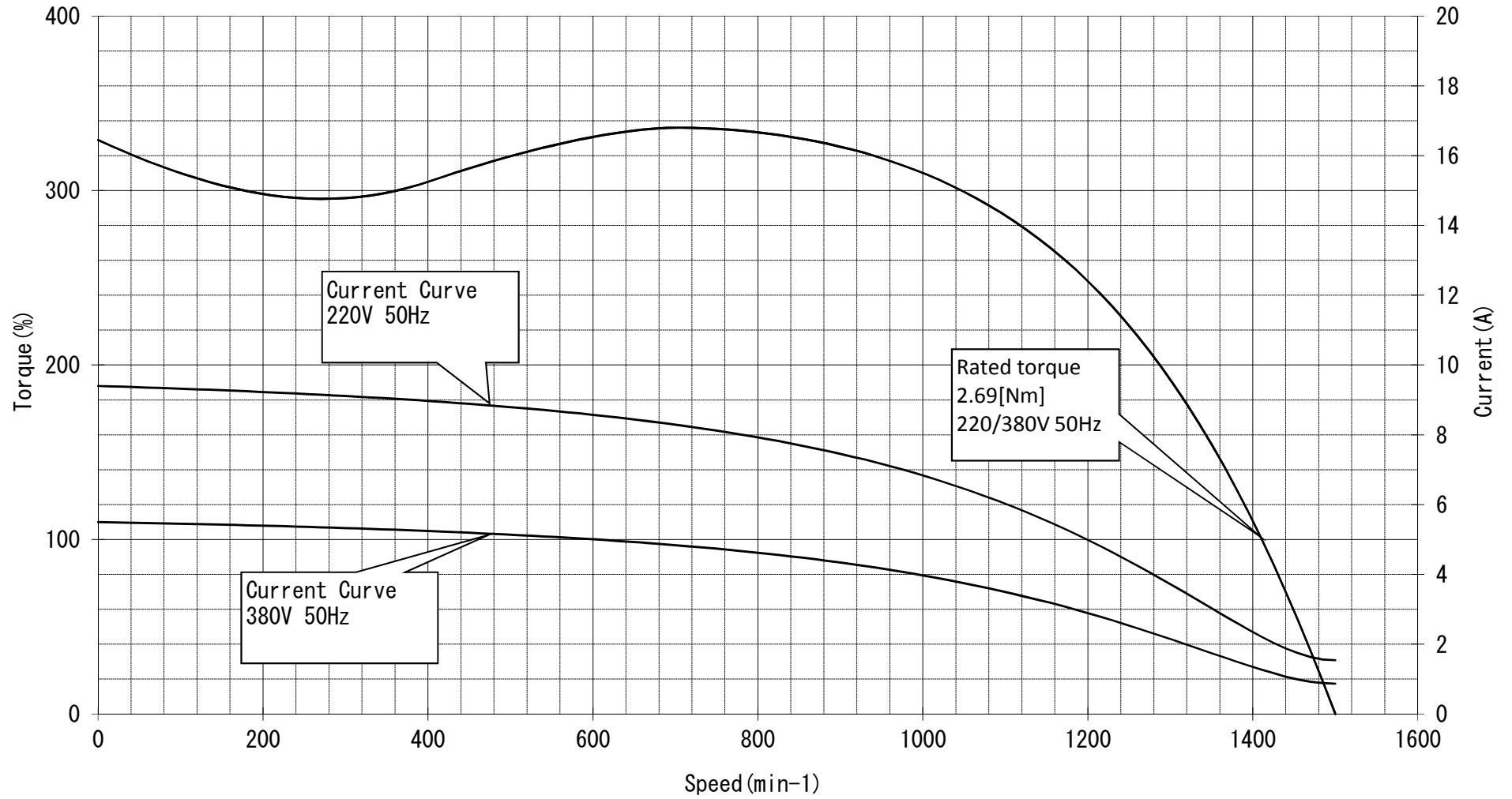

Three Phase Induction Motor Characteristic Curve

Hitachi Industrial Technology(Thailand),Ltd

Power (HP) 1/2
 Pole 4
 Type-Form TFO-K VTFO-K
 Voltage (V) 380
 Frequency (Hz) 50
 Protection IP44 , IP55

Load (%)	0	25	50	75	100	125
Current(A)	0.87	0.88	0.93	1.01	1.12	1.26
Efficiency(%)	0	50.0	65.1	71.2	73.6	74.0
Power factor(%)	16.1	32.1	46.9	59.2	68.9	76.0
Slip (%)	0	0.8	1.7	2.7	3.7	5.0

