

THREE-PHASE INDUCTION MOTOR

OUTPUT	TYPE	FORM	RATING	VOLTAGE (V)	FREQ. (Hz)	SYNC. SPEED (min ⁻¹)	POLES	TH. CLASS	MASS (kg)
75HP	TFO	KK	S1	380/415	50	1500	4	F	260
60HP	TFO	KK	S1	380/415	50	1000	6	F	265

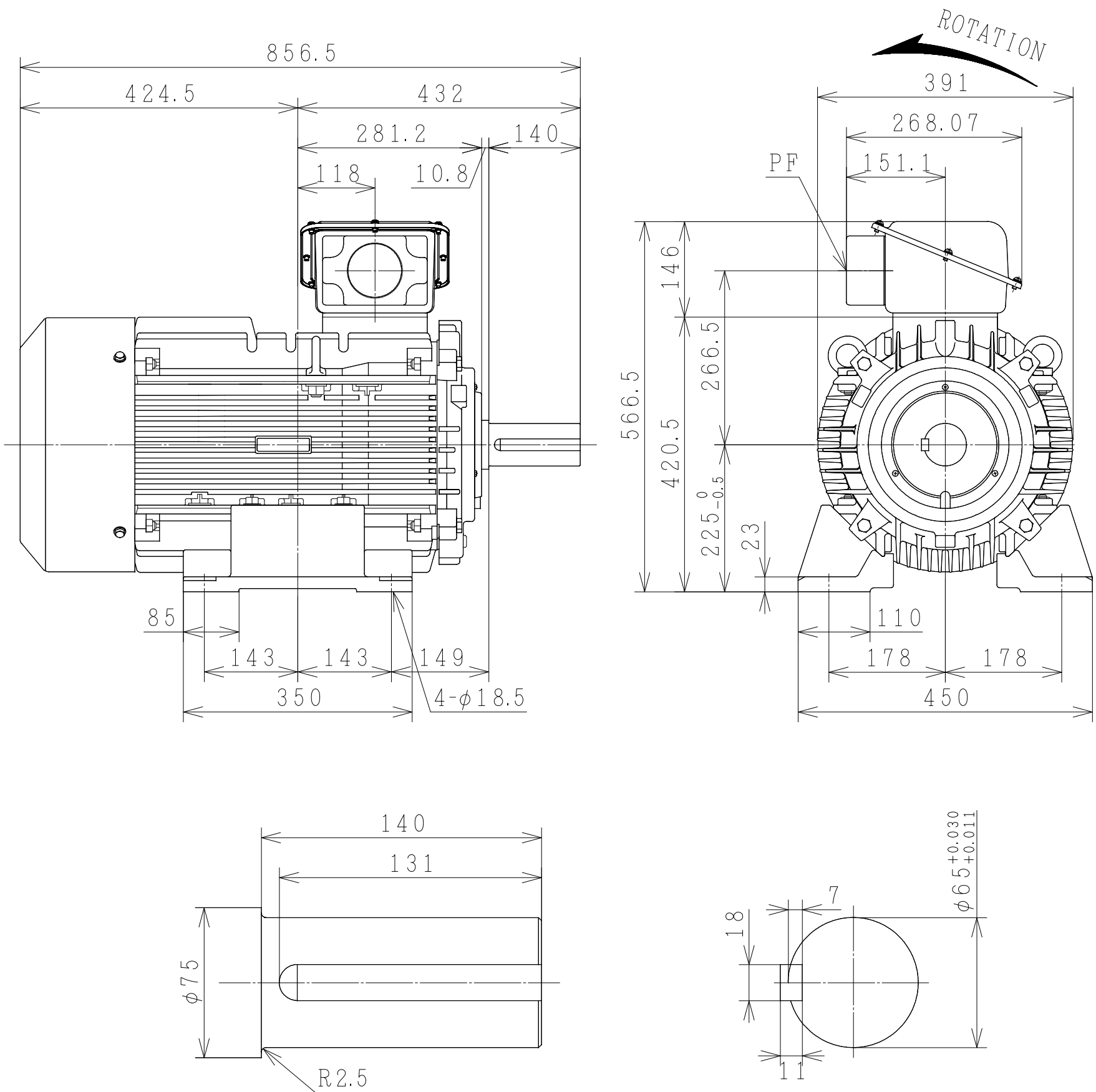

OUTPUT	POLES	PF
75HP	4P	PF3
60HP	6P	PF21/2

PROTECTION : IP55

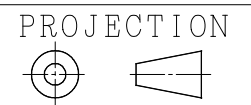

CUSTOMER	QTY.	ORDER No.	WORK No.	REV.
DIMENSIONS	HITACHI Hitachi Industrial Technology (Thailand),Ltd.		HITT WORKS DWG. No. 4HTD03380	SH.
	FRAME SIZE TFOAD-225S (TMHD)			

HITACHI

MANUFACTURER'S TEST REPORT OF INDUCTION MOTOR

MESSRS		ORDER No	
--------	--	----------	--

SPECIFICATION FOR MOTOR

OUT PUT(HP)	60	POLES	6	TYPE-FORM	TFO-KK
FREQUENCY(HZ)	50/50	VOLTAGE(V)	380/415	CURRENT(A)	88/88
PHASES	3	RATING	S1	INSULATION	F
STANDARD	JEC-2137-2000	SECONDARY VOLTAGE(V)	—	SECONDARY CURRENT(A)	—
COOLING	IC411	PROTECTION	IP55	SPEED(min ⁻¹)	970/975

MFG No	FREQUENCY (HZ)	(1)NO-LOAD TEST			(2)LOCKED ROTOR TEST		
		VOLTAGE(V)	CURRENT(A)	INPUT(W)	VOLTAGE(V)	CURRENT(A)	INPUT(W)
	50	380	32.20	1240.0	70.0	80.0	4000.0
	50	415	44.86	1720.0	70.0	80.0	4000.0

(3)WINDINGS RESISTANCE (BETWEEN LINES) STATOR 115°C 0.20460(Ω)

(4)LOAD CHARACTERISTICS

LOAD(%)	CURRENT(A)	EFFICIENCY(%)	POWER FACTOR(%)	SLIP(%)
25	37.78/48.46	88.3/84.8	51.2/38.0	0.4/0.4
50	50.77/57.77	91.8/90.1	73.4/60.0	0.9/0.7
75	67.79/71.06	92.0/91.1	82.3/72.3	1.3/1.1
100	87.48/87.15	91.1/90.9	85.8/78.8	1.9/1.6
125	109.71/105.52	89.7/90.1	86.8/82.1	2.5/2.1

(5)MAXIMUM OUT PUT(%) STARTING CURRENT(A) STARTING TORQUE(%)

222/259 536.0/591.5 248/300

(6)TEMPERATURE RISE TEST (R)-RESISTANCE METHOD

STATOR WINDINGS(K)	FRAME(K)	ROTOR WINDINGS(K)
77.5/80.5 (R)	55.5/57.0	—

(7)INSULATION RESISTANCE BY 500V MEGGER 100MΩ

(8)WITHSTAND STATOR WINDINGS TO CORE 1900V 1MIN WITHSTOOD
VOLTAGE TEST ROTOR WINDINGS TO CORE — V 1MIN WITHSTOOD

(9)CONSTRUCTION, DIMENSION, PAINTING, OTHER PARTS SATISFACTORY

HITACHI INDUSTRIAL TECHNOLOGY (THAILAND) LTD.	CHECKED BY	T.SHIMOZONO
	DATE	09-JUNE-2015

REP.No.RP30066

Three Phase Induction Motor Characteristic Curve

Hitachi Industrial Technology(Thailand),Ltd

Power (HP)	60
Pole	6
Type-Form	TFO-KK, VTFO-KK
Voltage (V)	380
Frequency (Hz)	50
Protection	IP44, IP55

Load (%)	0	25	50	75	100	125
Current (A)	32.20	37.78	50.77	67.79	87.48	109.71
Efficiency (%)	0	88.3	91.8	92.0	91.1	89.7
Power factor (%)	5.9	51.2	73.4	82.3	85.8	86.8
Slip (%)	0	0.4	0.9	1.3	1.9	2.5

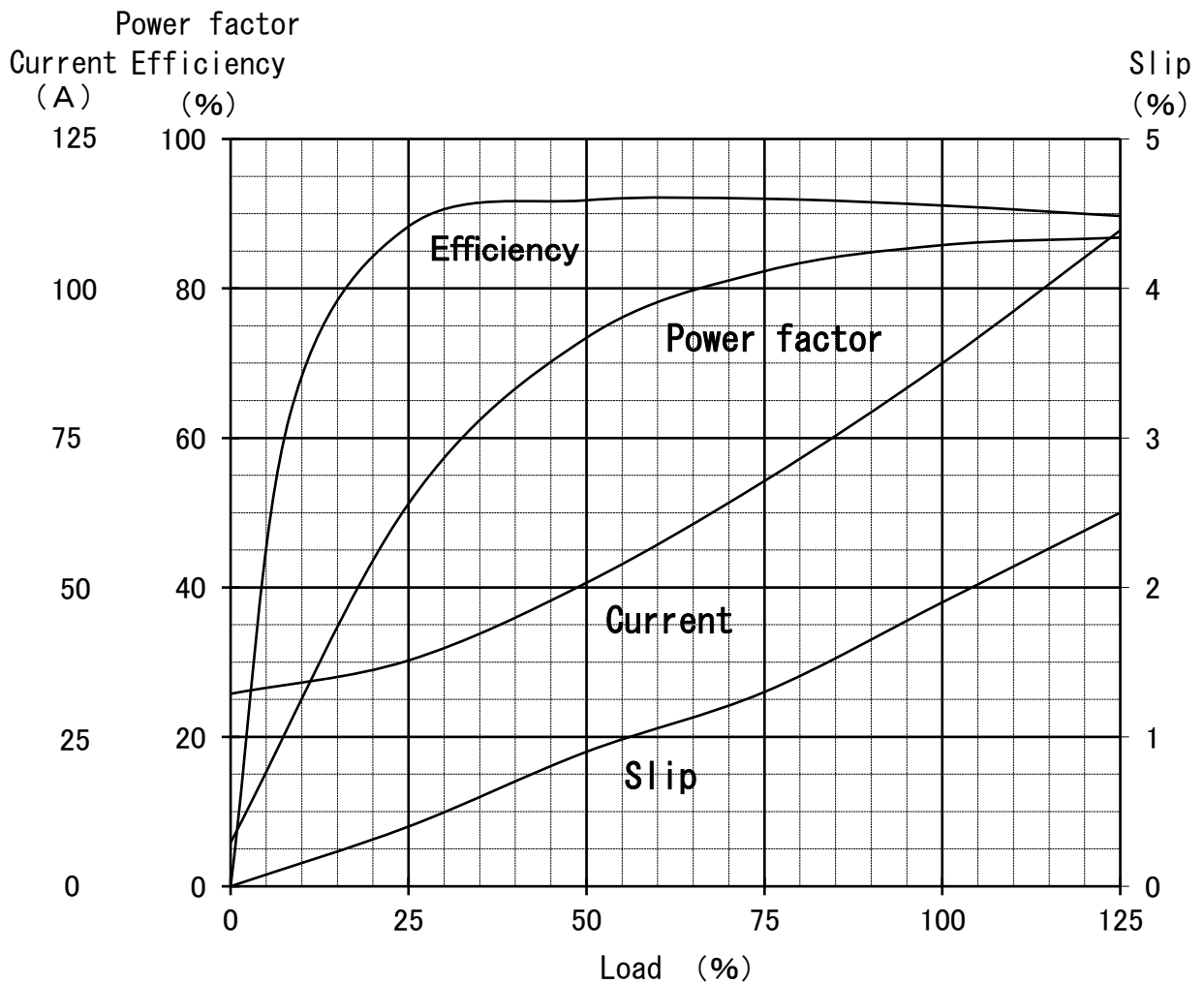

Speed-Torque, Current Curve

60HP (V) TF0-KK 6P
380/415V 50Hz
IP44/IP55

