

# THREE-PHASE INDUCTION MOTOR

OUTPUT	TYPE	FORM	RATING	VOLTAGE (V)	FREQ. (Hz)	SYNC. SPBED (min <sup>-1</sup> )	POLES	TH. CLASS	MASS (kg)
50HP	TFO	KK	S1	380/415	50	3000	2	F	200
60HP	TFO	KK	S1	380/415	50	3000	2	F	210
50HP	TFO	KK	S1	380/415	50	1500	4	F	210
60HP	TFO	KK	S1	380/415	50	1500	4	F	230
40HP	TFO	KK	S1	380/415	50	1000	6	F	220
50HP	TFO	KK	S1	380/415	50	1000	6	F	240

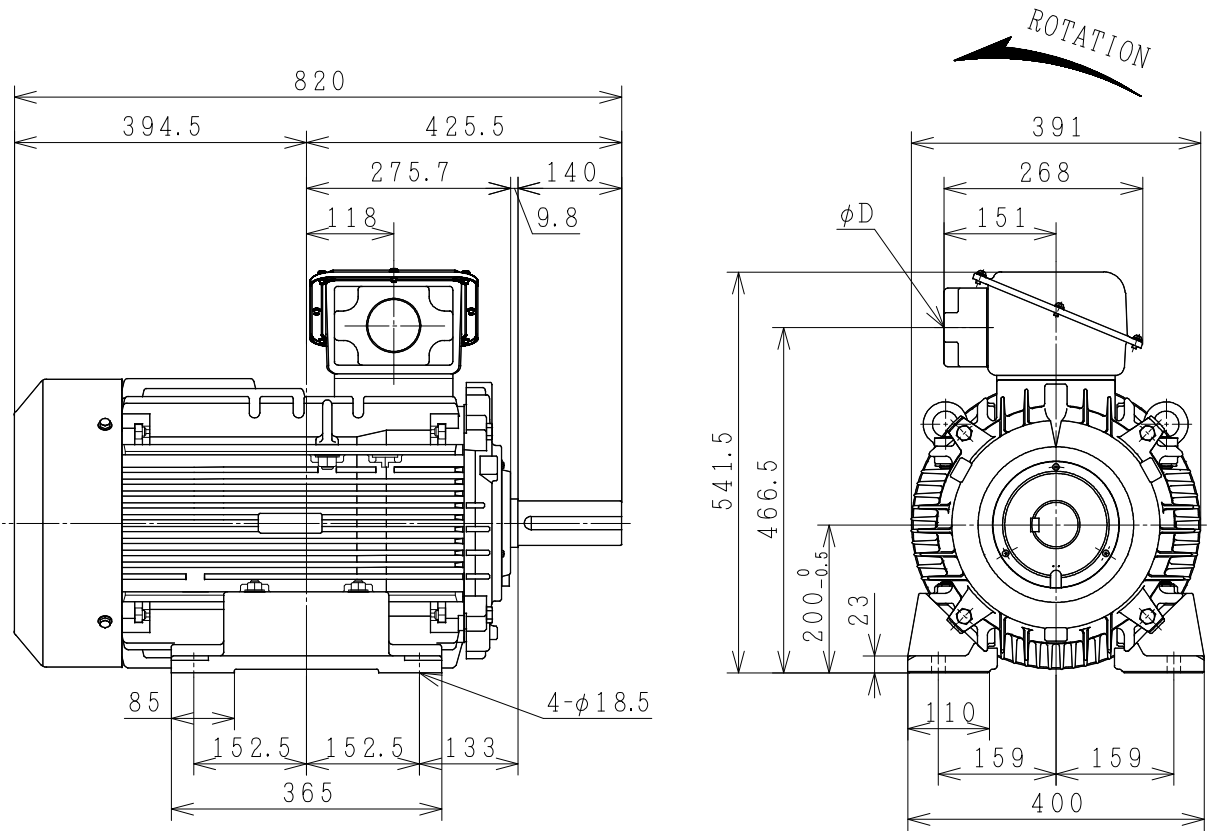

OUTPUT	POLES	φD
50HP	2P	PF2 <sup>1</sup> / <sub>2</sub>
60HP	2P	PF2 <sup>1</sup> / <sub>2</sub>
50HP	4P	PF2 <sup>1</sup> / <sub>2</sub>
60HP	4P	PF2 <sup>1</sup> / <sub>2</sub>
40HP	6P	PF2
50HP	6P	PF2 <sup>1</sup> / <sub>2</sub>

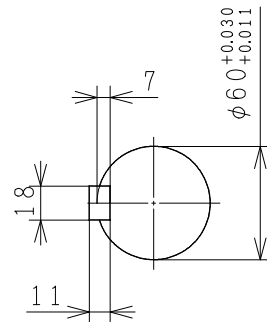
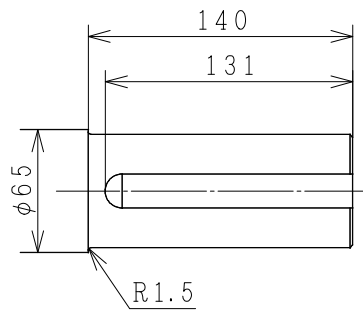

PROTECTION : IP55

PROJECTION

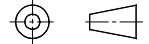

CUSTOMER	QTY.	ORDER No.	WORK No.	REV.
DIMENSIONS	<b>HITACHI</b> Hitachi Industrial Technology (Thailand), Ltd.		HITT WORKS DWG. No. 4HTD03378	SH.

FRAME SIZE TFO D-200L (TMHD)

# HITACHI

## MANUFACTURER'S TEST REPORT OF INDUCTION MOTOR

MESSRS		ORDER No	
--------	--	----------	--

### SPECIFICATION FOR MOTOR

OUT PUT(HP)	60	POLES	4	TYPE-FORM	TFO-KK
FREQUENCY(HZ)	50/50	VOLTAGE(V)	380/415	CURRENT(A)	87/85
PHASES	3	RATING	S1	INSULATION	F
TANDARD	JEC-2137-2000	SECONDARY VOLTAGE(V)	—	SECONDARY CURRENT(A)	—
COOLING	IC411	PROTECTION	IP55	SPEED(min <sup>-1</sup> )	1460/1465

MFG No	FREQUENCY (HZ)	NO-LOAD TEST			LOCKED ROTOR TEST		
		VOLTAGE(V)	CURRENT(A)	INPUT(W)	VOLTAGE(V)	CURRENT(A)	INPUT(W)
	50	380	27.07	1460.0	79.6	80.0	4050.0
	50	415	37.14	1840.0	79.6	80.0	4050.0

(3) WINDINGS RESISTANCE (BETWEEN LINES) STATOR 115°C 0.04093(Ω)

#### (4) LOAD CHARACTERISTICS

LOAD(%)	CURRENT(A)	EFFICIENCY(%)	POWERFACTOR(%)	SLIP(%)
25	33.91/41.75	87.2/84.5	57.8/44.3	0.4/0.3
50	48.24/52.52	91.5/90.2	77.5/65.9	0.7/0.6
75	66.16/67.07	92.2/91.2	84.1/76.3	1.1/1.0
100	86.62/84.17	91.7/91.6	86.1/81.0	1.6/1.3
125	109.96/103.52	90.6/91.1	85.8/82.8	2.1/1.7

(5) MAXIMUM OUT PUT(%) STARTING CURRENT(A) STARTING TORQUE(%)

206/242 541.5/602.0 243/302

#### (6) TEMPERATURE RISE TEST (R)-RESISTANCE METHOD

STATOR WINDINGS(K)	FRAME(K)	ROTOR WINDINGS(K)
80.0/76.0 (R)	56.0/53.0	-

(7) INSULATION RESISTANCE BY 500V MEGGER

100MΩ

(8) WITHSTAND STATOR WINDINGS TO CORE 1900V 1MIN WITHSTOOD  
 VOLTAGE TEST ROTOR WINDINGS TO CORE —V 1MIN WITHSTOOD

(9) CONSTRUCTION, DIMENSION, PAINTING, OTHER PARTS SATISFACTORY

HITACHI INDUSTRIAL TECHNOLOGY (THAILAND) LTD.	CHECKED BY	T.SHIMOZONO
	DATE	27-MAY.-2015

# Speed-Torque, Current Curve

60HP (V) TF0-KK 4P  
380/415V 50Hz  
IP44/IP55

