

THREE-PHASE INDUCTION MOTOR

OUTPUT	TYPE	FORM	RATING	VOLTAGE (V)	FREQ. (Hz)	SYNC. SPBBD (min ⁻¹)	POLES	TH. CLASS	MASS (kg)
50HP	TFO	KK	S1	380/415	50	3000	2	F	200
60HP	TFO	KK	S1	380/415	50	3000	2	F	210
50HP	TFO	KK	S1	380/415	50	1500	4	F	210
60HP	TFO	KK	S1	380/415	50	1500	4	F	230
40HP	TFO	KK	S1	380/415	50	1000	6	F	220
50HP	TFO	KK	S1	380/415	50	1000	6	F	240

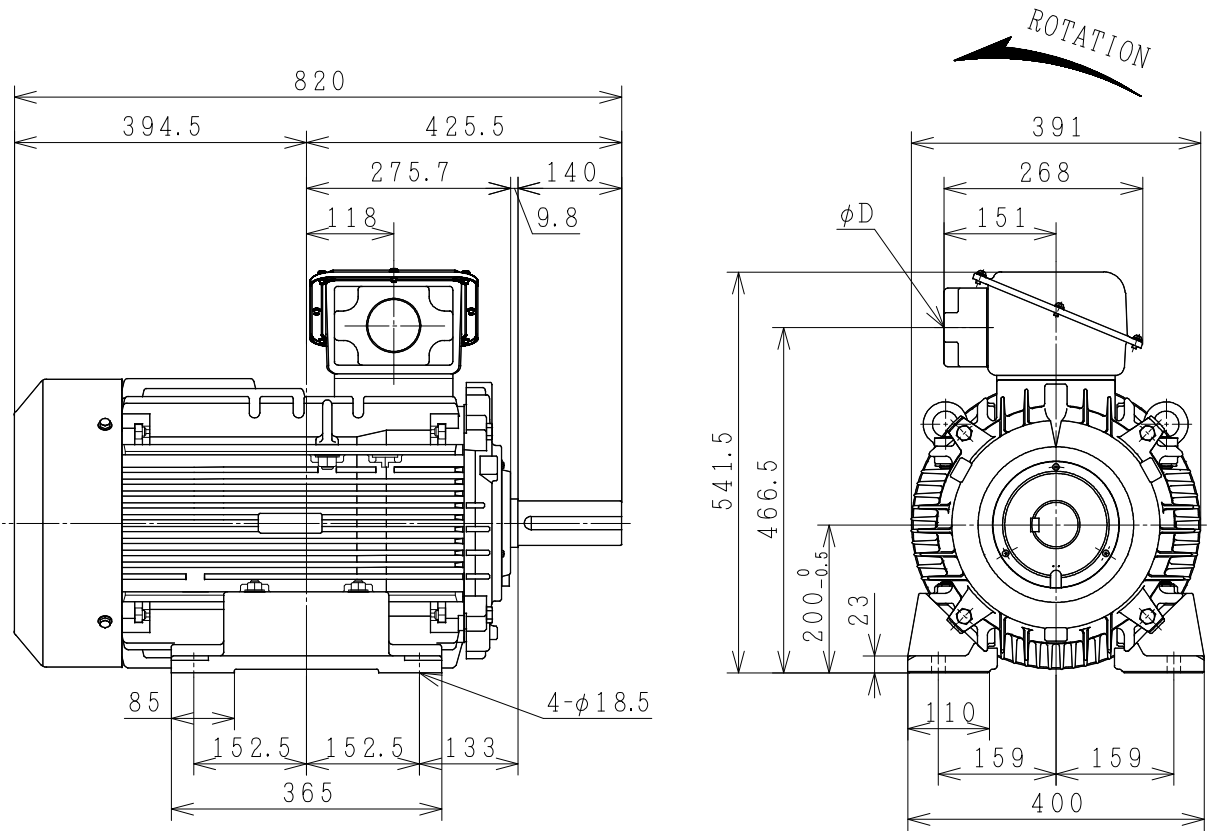

OUTPUT	POLES	φD
50HP	2P	PF2 ¹ / ₂
60HP	2P	PF2 ¹ / ₂
50HP	4P	PF2 ¹ / ₂
60HP	4P	PF2 ¹ / ₂
40HP	6P	PF2
50HP	6P	PF2 ¹ / ₂

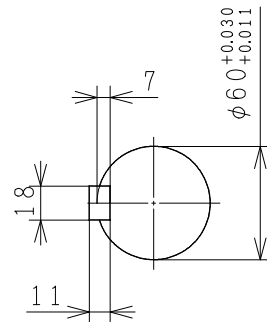
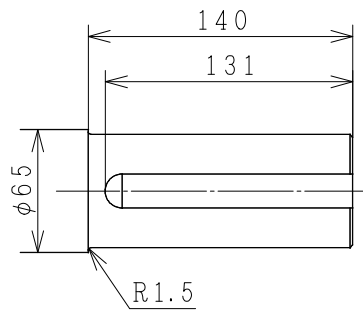

PROTECTION : IP55

PROJECTION

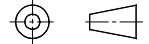

CUSTOMER	QTY.	ORDER No.	WORK No.	REV.
DIMENSIONS	HITACHI Hitachi Industrial Technology (Thailand), Ltd.		HITT WORKS DWG. No. 4HTD03378	SH.

FRAME SIZE TFO D-200L (TMHD)

HITACHI

MANUFACTURER'S TEST REPORT OF INDUCTION MOTOR

MESSRS		ORDER No	
--------	--	----------	--

SPECIFICATION FOR MOTOR

OUT PUT(HP)	40	POLES	6	TYPE-FORM	TFO-KK
FREQUENCY(HZ)	50/50	VOLTAGE(V)	380/415	CURRENT(A)	60.5/61.0
PHASES	3	RATING	S1	INSULATION	F
STANDARD	JEC-2137-2000	SECONDARY VOLTAGE(V)	—	SECONDARY CURRENT(A)	—
COOLING	IC411	PROTECTION	IP55	SPEED(min ⁻¹)	965/970

MFG No	FREQUENCY (HZ)	(1)NO-LOAD TEST			(2)LOCKED ROTOR TEST		
		VOLTAGE(V)	CURRENT(A)	INPUT(W)	VOLTAGE(V)	CURRENT(A)	INPUT(W)
	50	380	24.73	1040.0	75.0	60.0	3125.0
	50	415	33.20	1400.0	75.0	60.0	3125.0

(3)WINDINGS RESISTANCE (BETWEEN LINES) STATOR 115°C 0.29524 (Ω)

(4)LOAD CHARACTERISTICS

LOAD(%)	CURRENT(A)	EFFICIENCY(%)	POWER FACTOR(%)	SLIP(%)
25	28.13/35.44	86.1/82.3	47.1/35.7	0.4/0.3
50	36.24/41.28	90.7/88.7	69.4/56.8	0.8/0.7
75	47.14/49.74	91.3/90.3	79.4/69.5	1.2/1.0
100	59.91/60.10	90.8/90.5	83.8/76.6	1.6/1.4
125	74.35/71.99	89.7/89.9	85.4/80.4	2.1/1.8

(5)MAXIMUM OUT PUT(%) STARTING CURRENT(A) STARTING TORQUE(%)

226/265 380/421 226/277

(6)TEMPERATURE RISE TEST (R)-RESISTANCE METHOD

STATOR WINDINGS(K)	FRAME(K)	ROTOR WINDINGS(K)
61.0/61.0 (R)	39.5/39.5	—

(7)INSULATION RESISTANCE BY 500V MEGGER 100MΩ

(8)WITHSTAND STATOR WINDINGS TO CORE 1900V 1MIN WITHSTOOD
 VOLTAGE TEST ROTOR WINDINGS TO CORE — V 1MIN WITHSTOOD

(9)CONSTRUCTION, DIMENSION, PAINTING, OTHER PARTS SATISFACTORY

HITACHI INDUSTRIAL TECHNOLOGY (THAILAND) LTD.	CHECKED BY	T.SHIMOZONO
	DATE	09-Jun-2015

REP.No.RP30061

Three Phase Induction Motor Characteristic Curve

Hitachi Industrial Technology(Thailand),Ltd

Power (HP) 40
 Pole 6
 Type-Form TFO-KK,VTFO-KK
 Voltage (V) 380
 Frequency (Hz) 50
 Protection IP44,IP55

Load (%)	0	25	50	75	100	125
Current(A)	24.74	28.14	36.25	47.15	59.91	74.36
Efficiency(%)	0	86.1	90.7	91.3	90.8	89.7
Power factor(%)	6.4	47.1	69.4	79.4	83.8	85.4
Slip (%)	0	0.4	0.8	1.2	1.6	2.1

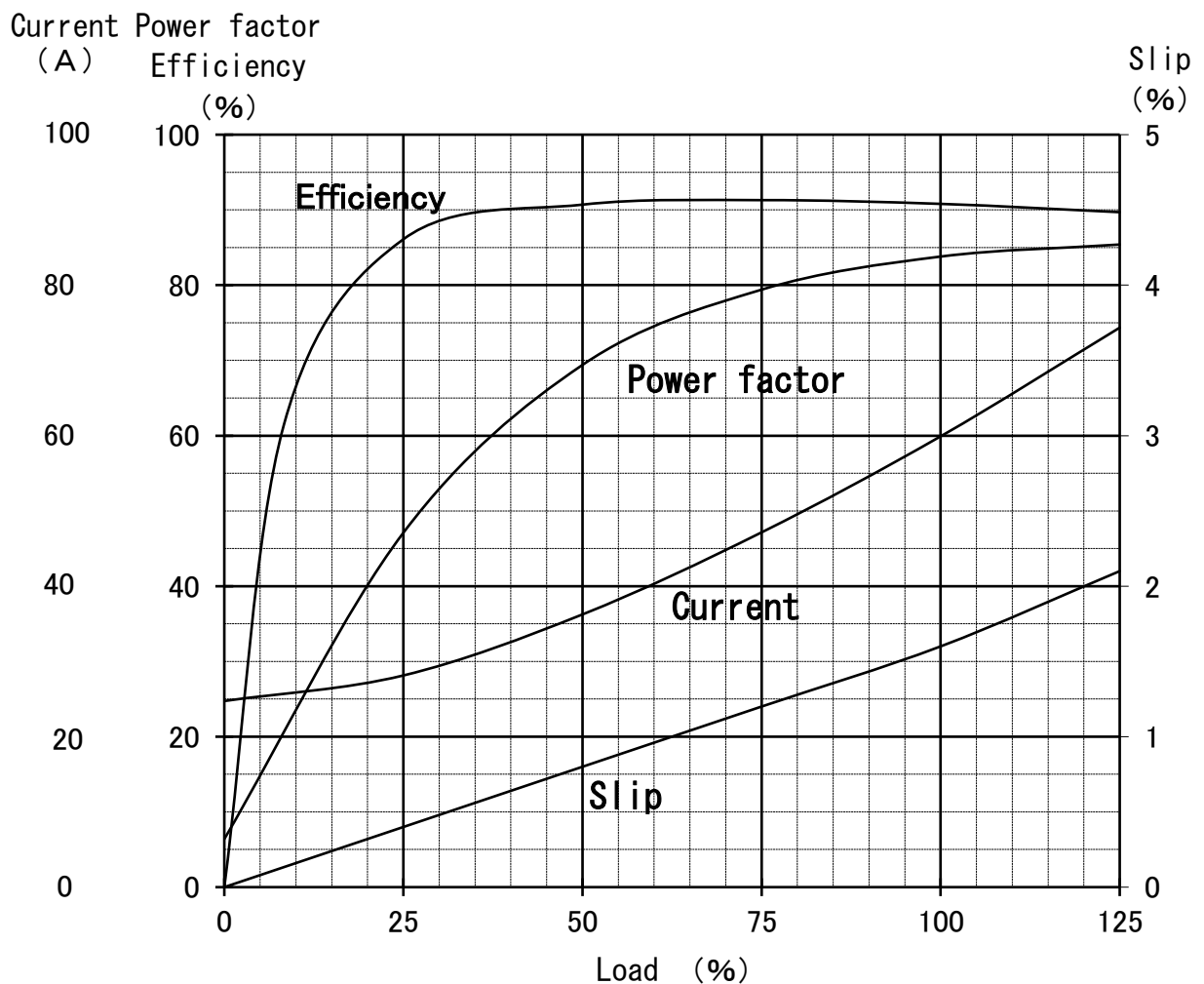

Speed-Torque, Current Curve

40HP (V) TF0-KK 6P
380/415V 50Hz
IP44/IP55

