

# THREE-PHASE INDUCTION MOTOR

OUTPUT	TYPE	FORM	RATING	VOLTAGE (V)	FREQ. (Hz)	SYNC. SPEED (min <sup>-1</sup> )	POLES	TH. CLASS	MASS (kg)
40HP	TFO	KK	S1	380/415	50	3000	2	F	140
40HP	TFO	KK	S1	380/415	50	1500	4	F	155
25HP	TFO	KK	S1	380/415	50	1000	6	F	150
30HP	TFO	KK	S1	380/415	50	1000	6	F	160

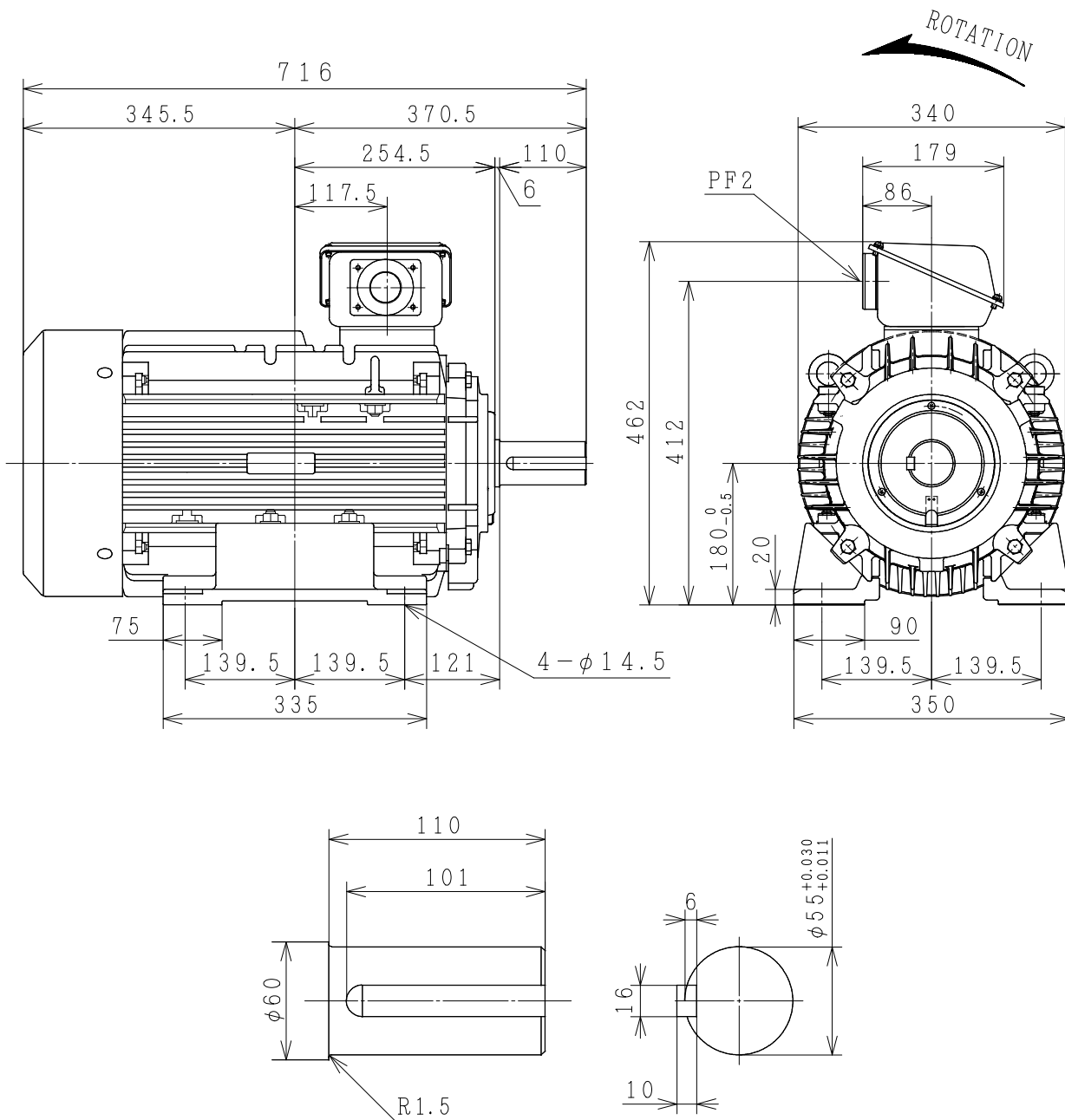

PROTECTION : IP55

PROJECTION

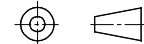

CUSTOMER	QTY.	ORDER No.	WORK No.	REV.
<h2 style="margin: 0;">DIMENSIONS</h2>	<b>HITACHI</b> Hitachi Industrial Technology (Thailand), Ltd.		HITT WORKS DWG. No. <b>4HTD03376</b>	SH.
	FRAME SIZE TFOD-180L (TMHD)			

# HITACHI

## MANUFACTURER'S TEST REPORT OF INDUCTION MOTOR

MESSRS		ORDER No	
--------	--	----------	--

### SPECIFICATION FOR MOTOR

OUT PUT(HP)	30	POLES	6	TYPE-FORM	TFO-KK
FREQUENCY(HZ)	50/50	VOLTAGE(V)	380/415	CURRENT(A)	44.5/44.0
PHASES	3	RATING	S1	INSULATION	F
STANDARD	JEC-2137-2000	SECONDARY VOLTAGE(V)	—	SECONDARY CURRENT(A)	—
COOLING	IC411	PROTECTION	IP55	SPEED(min <sup>-1</sup> )	965/965

MFG No	FREQUENCY (HZ)	(1)NO-LOAD TEST			(2)LOCKED ROTOR TEST		
		VOLTAGE(V)	CURRENT(A)	INPUT(W)	VOLTAGE(V)	CURRENT(A)	INPUT(W)
	50	380	17.75	850.0	71.0	40.0	2000.0
	50	415	23.75	1150.0	71.0	40.0	2000.0

(3)WINDINGS RESISTANCE (BETWEEN LINES) STATOR 115°C 0.43656 (Ω)

#### (4)LOAD CHARACTERISTICS

LOAD(%)	CURRENT(A)	EFFICIENCY(%)	POWER FACTOR(%)	SLIP(%)
25	20.34/25.48	84.7/80.5	48.5/37.2	0.4/0.3
50	26.40/29.87	89.8/87.7	70.5/58.3	0.8/0.7
75	34.48/36.18	90.6/89.5	80.2/70.8	1.2/1.0
100	43.94/43.87	90.1/89.7	84.4/77.6	1.6/1.4
125	54.65/52.69	89.0/89.2	85.9/81.2	2.2/1.8

(5)MAXIMUM OUT PUT(%) STARTING CURRENT(A) STARTING TORQUE(%)

228/267 278.5/309.5 263/326

(6)TEMPERATURE RISE TEST (R)-RESISTANCE METHOD

STATOR WINDINGS(K)	FRAME(K)	ROTOR WINDINGS(K)
67.0/64.5 (R)	55.5/53.5	—

(7)INSULATION RESISTANCE BY 500V MEGGER 100MΩ

(8)WITHSTAND STATOR WINDINGS TO CORE 1900V 1MIN WITHSTOOD  
 VOLTAGE TEST ROTOR WINDINGS TO CORE — V 1MIN WITHSTOOD

(9)CONSTRUCTION, DIMENSION, PAINTING, OTHER PARTS SATISFACTORY

HITACHI INDUSTRIAL TECHNOLOGY (THAILAND) LTD.	CHECKED BY	T.SHIMOZONO
	DATE	9-JUN-2015

REP.No. RP30056

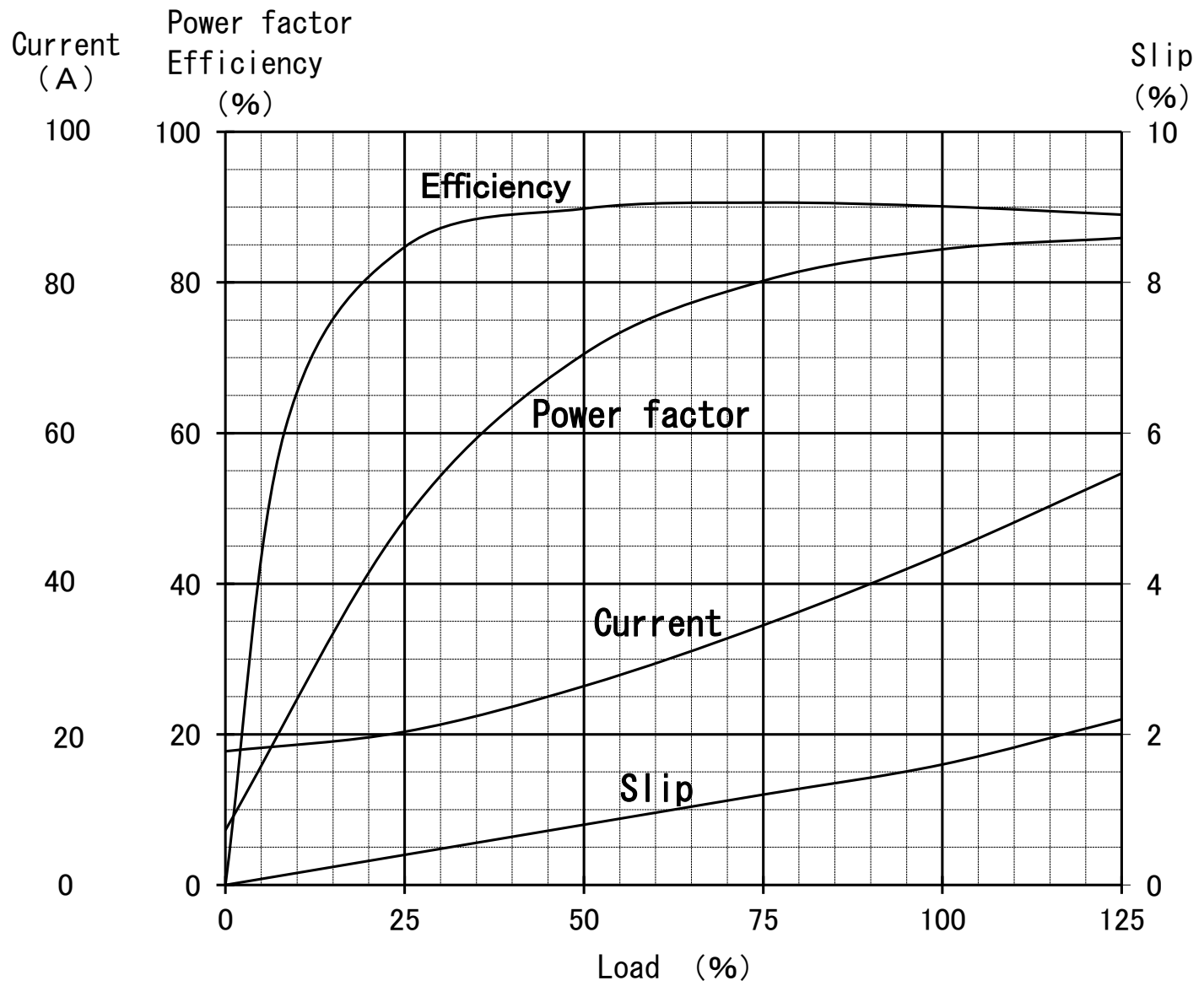

# Speed-Torque, Current Curve

30HP (V) TF0-KK 6P  
380/415V 50Hz  
IP44/IP55

