

THREE-PHASE INDUCTION MOTOR

OUTPUT	TYPE	FORM	RATING	VOLTAGE (V)	FREQ. (Hz)	SYNC. SPBBD (min ⁻¹)	POLES	TH. CLASS	MASS (kg)
30HP	TFO	KK	S1	380/415	50	3000	2	F	115
25HP	TFO	KK	S1	380/415	50	1500	4	F	120
30HP	TFO	KK	S1	380/415	50	1500	4	F	130
20HP	TFO	KK	S1	380/415	50	1000	6	F	135

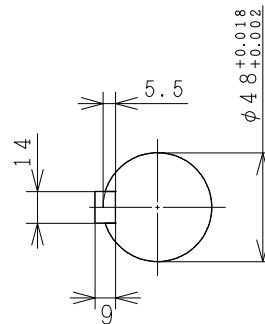
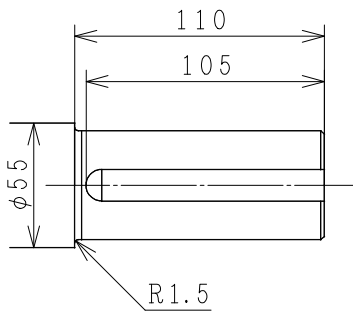
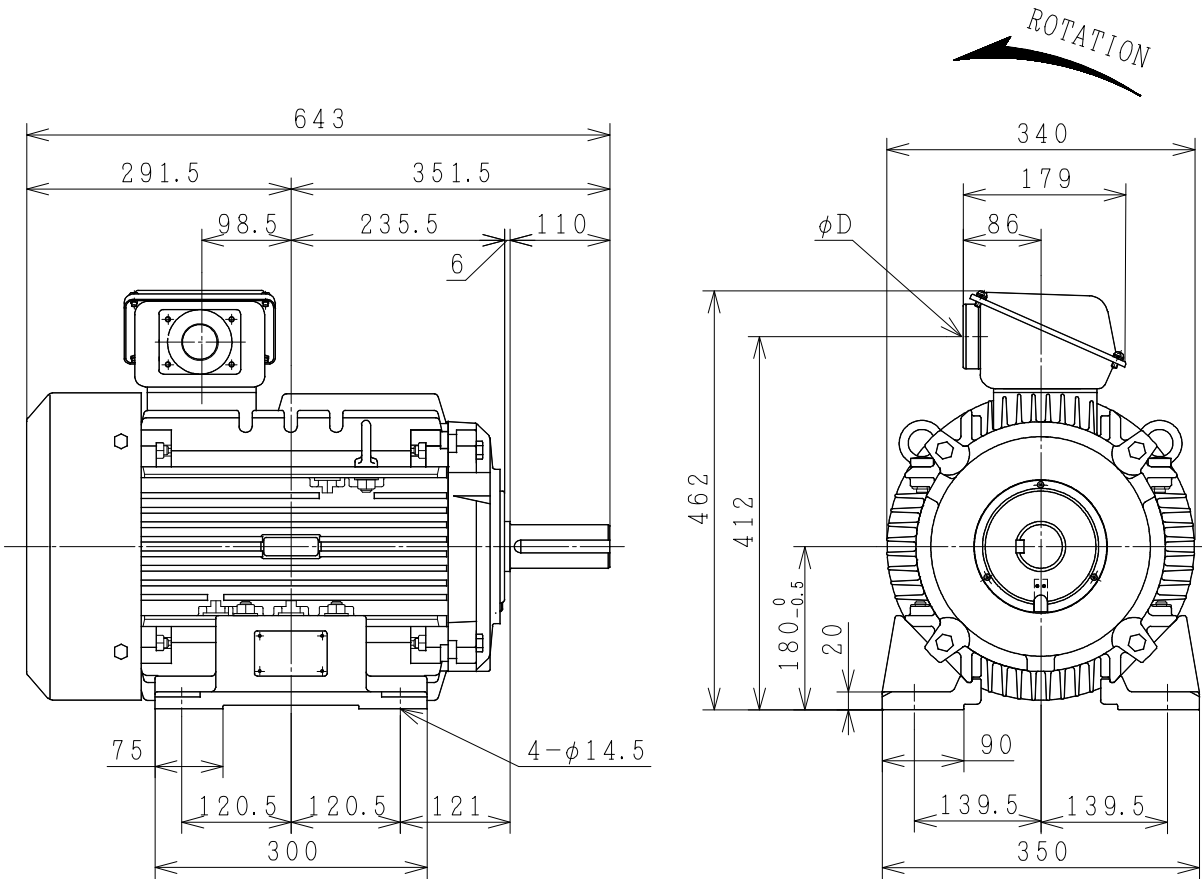

OUTPUT	POLES	φ D
30HP	2P	PF2
25HP	4P	PF2
30HP	4P	PF2
20HP	6P	PF1½

PROTECTION : IP55

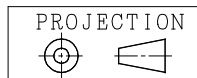

CUSTOMER	QTY.	ORDER No.	WORK No.	REV.
DIMENSIONS	HITACHI Hitachi Industrial Technology (Thailand), Ltd.		HITT WORKS DWG. No. 4HTD03374	SH.

FRAME SIZE TFOD-180M (TMHD)

THREE-PHASE INDUCTION MOTOR

OUTPUT	TYPE	FORM	RATING	VOLTAGE (V)	FREQ. (Hz)	SYNC. SPEED (min ⁻¹)	POLES	INS. CLASS	MASS (kg)
30HP	TFO	KK	S1	380/415	50	3000	2	F	115
25HP	TFO	KK	S1	380/415	50	1500	4	F	120
30HP	TFO	KK	S1	380/415	50	1500	4	F	130
20HP	TFO	KK	S1	380/415	50	1000	6	F	135

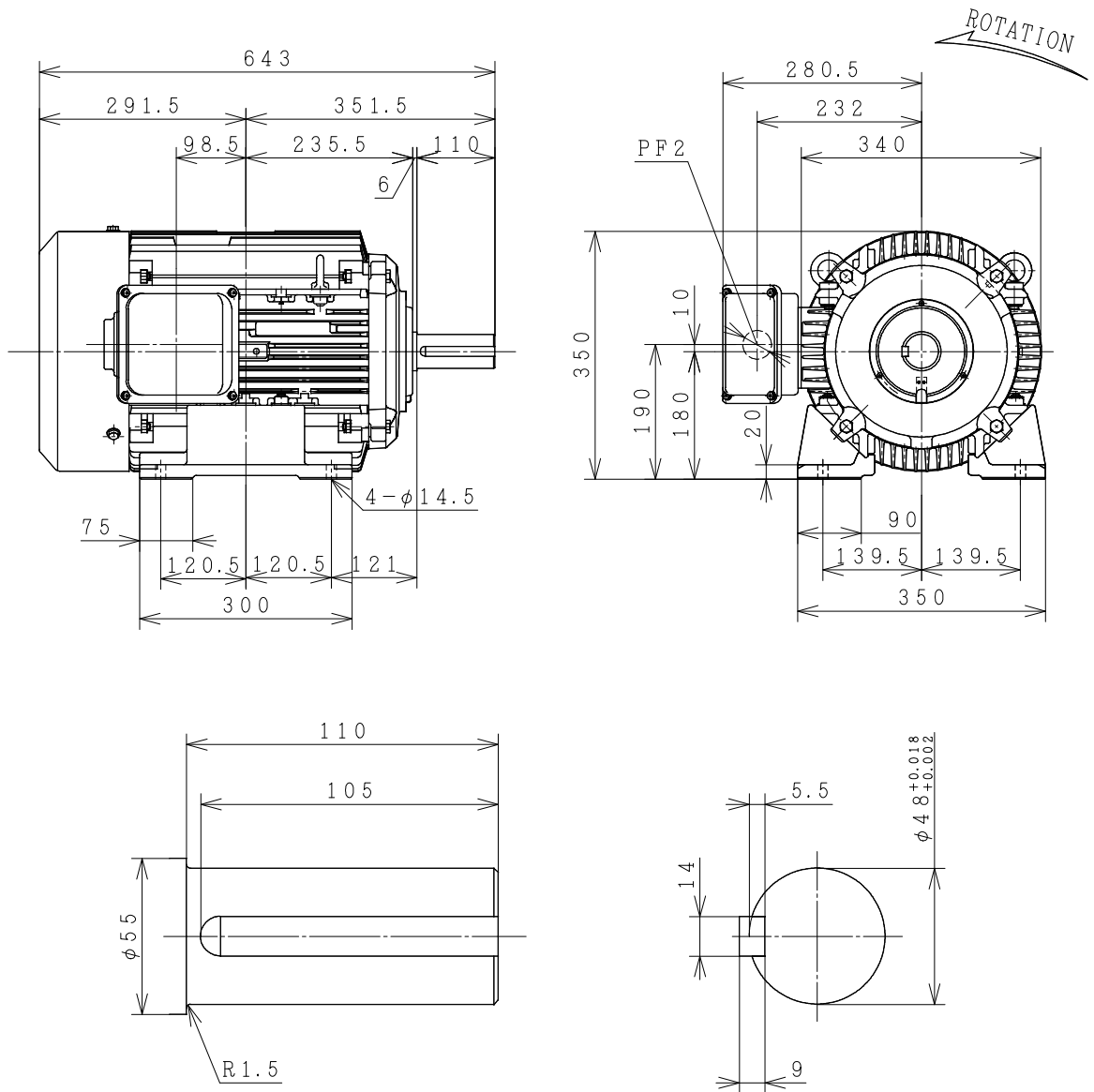

PROTECTION: IP55

PROJECTION

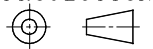

CUSTOMER			QTY.	ORDER No.	WORK No.	REV.	
DWN.	P.Tianchai	06-02-14	<div style="display: flex; justify-content: space-around; align-items: center;"> <div style="font-size: 2em; font-weight: bold;">DIMENSIONS</div> <div style="text-align: center;"> HITACHI <small>Hitachi Industrial Technology (Thailand), Ltd.</small> </div> <div style="font-size: 1.5em; font-weight: bold;">4HTD02789</div> </div>			HITT WORKS DWG. No.	SH.
CHKD.	W.Thawat	S					
APPD.	T.SHIMOZONO						
FRAME SIZE			TFOD-180M (TMLR)				

HITACHI

MANUFACTURER'S TEST REPORT OF INDUCTION MOTOR

MESSRS		ORDER No	
--------	--	----------	--

SPECIFICATION FOR MOTOR

OUT PUT(HP)	25	POLES	4	TYPE-FORM	TFO-KK
FREQUENCY(HZ)	50/50	VOLTAGE(V)	380/415	CURRENT(A)	36.5/37.0
PHASES	3	RATING	S1	INSULATION	F
TANDARD	JEC-2137-2000	SECONDARY VOLTAGE(V)	—	SECONDARY CURRENT(A)	—
COOLING	IC411	PROTECTION	IP55	SPEED(min ⁻¹)	1455/1455

MFG No	FREQUENCY (HZ)	NO-LOAD TEST			LOCKED ROTOR TEST		
		VOLTAGE(V)	CURRENT(A)	INPUT(W)	VOLTAGE(V)	CURRENT(A)	INPUT(W)
	50	380	12.64	680.0	77.0	35.0	1850.0
	50	415	18.09	940.0	77.0	35.0	1850.0

(3) WINDINGS RESISTANCE (BETWEEN LINES) STATOR 115°C 0.46930(Ω)

(4) LOAD CHARACTERISTICS

LOAD(%)	CURRENT(A)	EFFICIENCY(%)	POWERFACTOR(%)	SLIP(%)
25	15.16/19.72	85.8/81.6	54.0/39.9	0.4/0.3
50	20.67/23.68	90.6/88.4	75.1/61.4	0.8/0.7
75	27.72/29.21	91.4/90.2	83.3/73.1	1.2/1.1
100	35.77/35.82	91.0/90.4	86.4/79.3	1.7/1.5
125	44.79/43.32	89.9/90.0	87.3/82.4	2.3/1.9

(5) MAXIMUM OUT PUT(%) STARTING CURRENT(A) STARTING TORQUE(%)

220/257 241.0/268.0 268/331

(6) TEMPERATURE RISE TEST (R)-RESISTANCE METHOD

STATOR WINDINGS(K)	FRAME(K)	ROTOR WINDINGS(K)
69.0/69.0 (R)	45.0/45.0	

(7) INSULATION RESISTANCE BY 500V MEGGER

100MΩ

(8) WITHSTAND STATOR WINDINGS TO CORE

1900V 1MIN WITHSTOOD

VOLTAGE TEST ROTOR WINDINGS TO CORE

— V 1MIN WITHSTOOD

(9) CONSTRUCTION, DIMENSION, PAINTING, OTHER PARTS

SATISFACTORY

HITACHI INDUSTRIAL TECHNOLOGY (THAILAND) LTD.	CHECKED BY	T.SHIMOZONO
	DATE	9-JUNE-2015

REP.No RP20317

Three Phase Induction Motor Characteristic Curve

Hitachi Industrial Technology(Thailand),Ltd

Power (HP)	25
Pole	4
Type-Form	TFO-KK,VTFO-KK
Voltage (V)	380
Frequency (Hz)	50
Protection	IP44,IP55

Load (%)	0	25	50	75	100	125
Current(A)	12.64	15.16	20.67	27.72	35.77	44.79
Efficiency(%)	0	85.8	90.6	91.4	91.0	89.9
Power factor(%)	8.2	54.0	75.1	83.3	86.4	87.3
Slip (%)	0	0.4	0.8	1.2	1.7	2.3

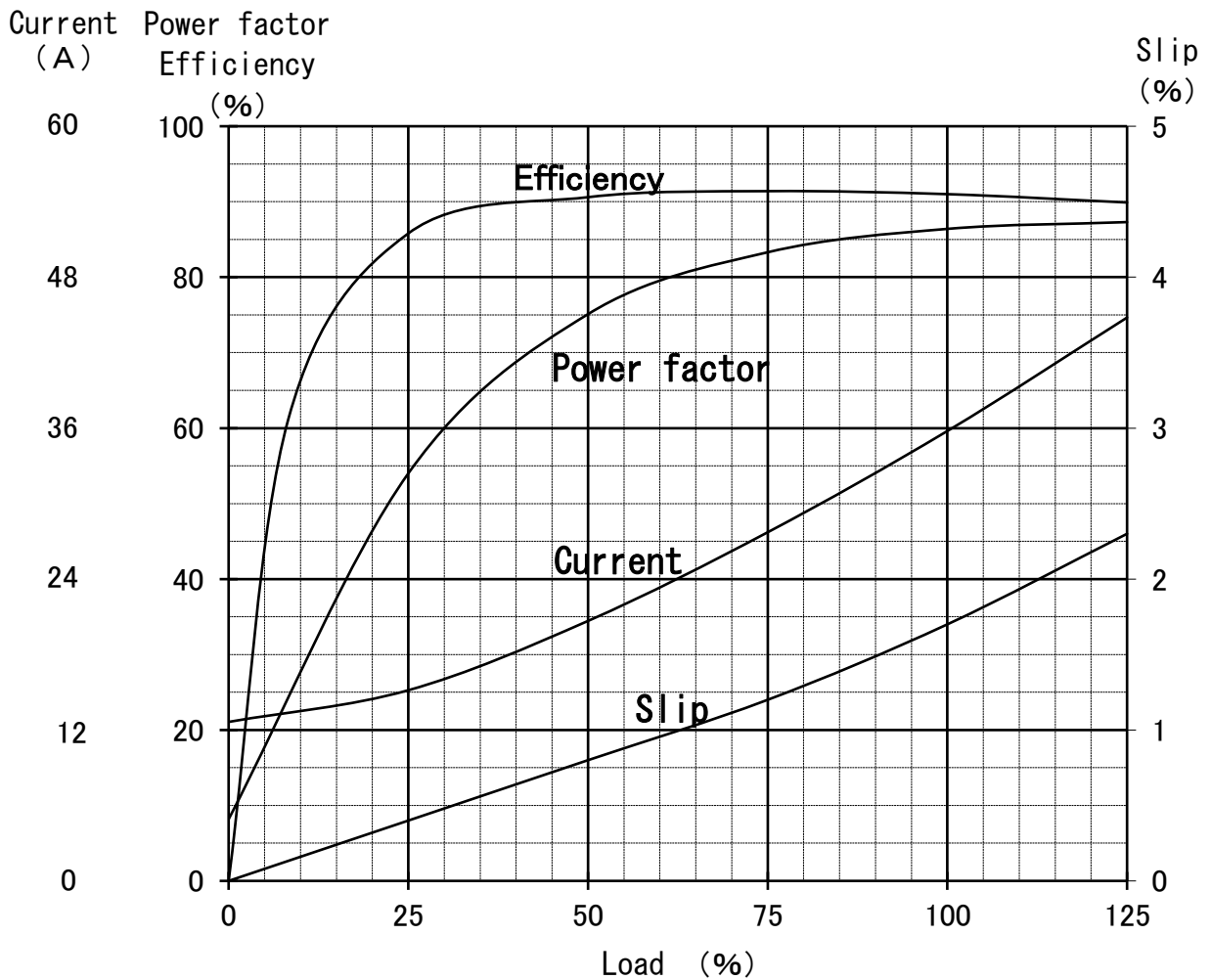

Speed-Torque, Current Curve

25HP (V) TF0-KK 4P
380/415V 50Hz
IP44/IP55

