

THREE-PHASE INDUCTION MOTOR

OUTPUT	TYPE	FORM	RATING	VOLTAGE (V)	FREQ. (Hz)	SYNC. SPEED (min ⁻¹)	POLES	TH. CLASS	MASS (kg)
15HP	TFO	KK	S1	380/415	50	3000	2	F	70
20HP	TFO	KK	S1	380/415	50	3000	2	F	79
15HP	TFO	KK	S1	380/415	50	1500	4	F	73
10HP	TFO	KK	S1	380/415	50	1000	6	F	75

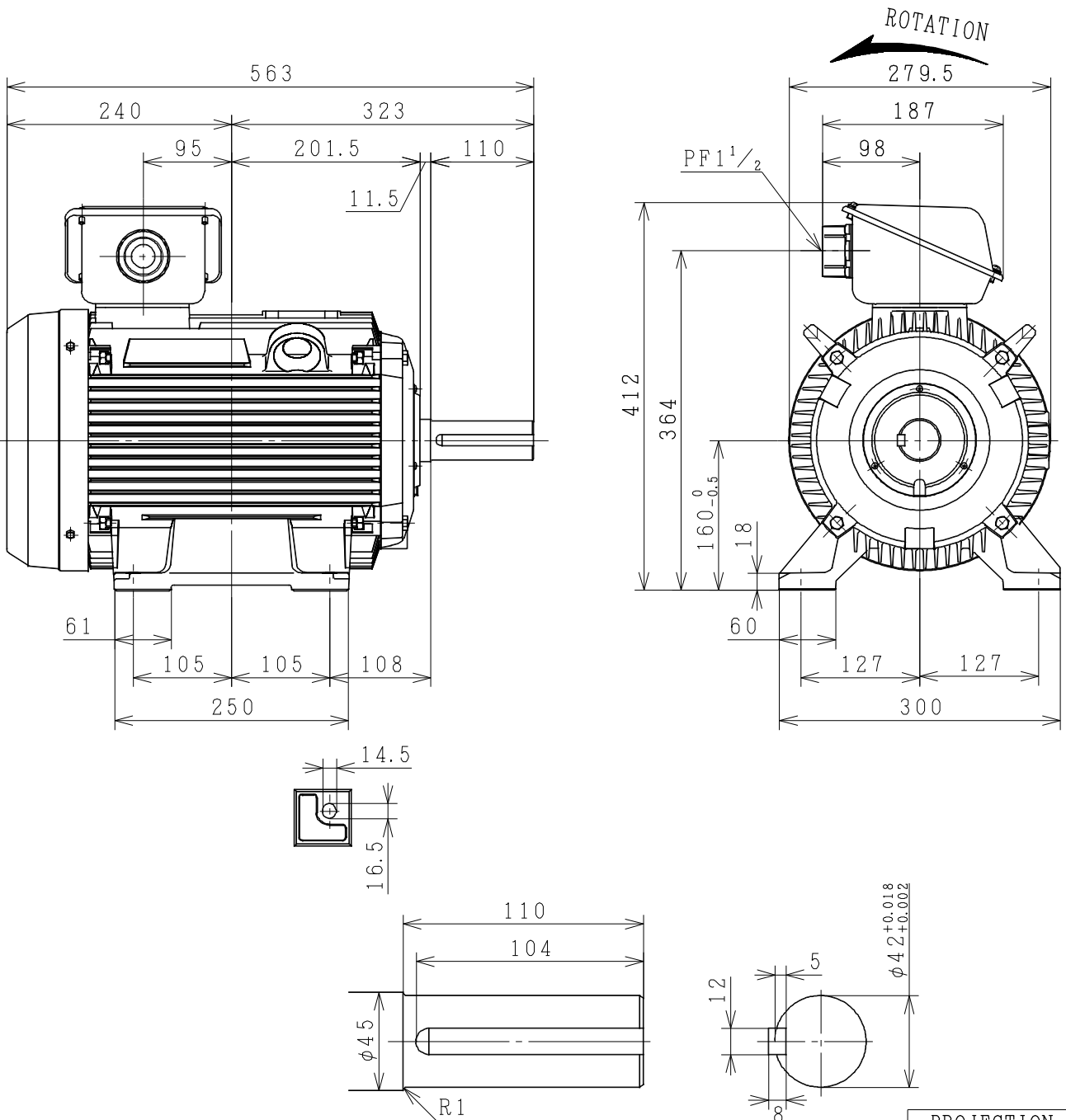

PROTECTION : IP55

PROJECTION

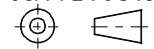

CUSTOMER	QTY.	ORDER No.	WORK No.	REV.
DIMENSIONS	HITACHI Hitachi Industrial Technology (Thailand), Ltd.		HITT WORKS DWG. No. 4HTD03370	SH.

FRAME SIZE TFOD-160M (TMHD)

THREE-PHASE INDUCTION MOTOR

OUTPUT	TYPE	FORM	RATING	VOLTAGE (V)	FREQ. (Hz)	SYNC. SPEED (min ⁻¹)	POLES	INS. CLASS	MASS (kg)
15HP	TFO	KK	S1	380/415	50	3000	2	F	70
20HP	TFO	KK	S1	380/415	50	3000	2	F	79
15HP	TFO	KK	S1	380/415	50	1500	4	F	73
10HP	TFO	KK	S1	380/415	50	1000	6	F	75

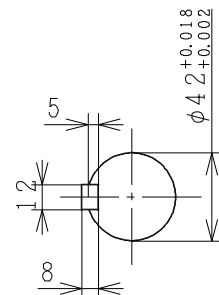
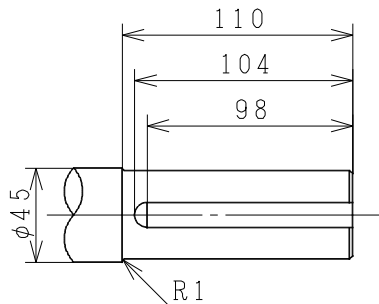
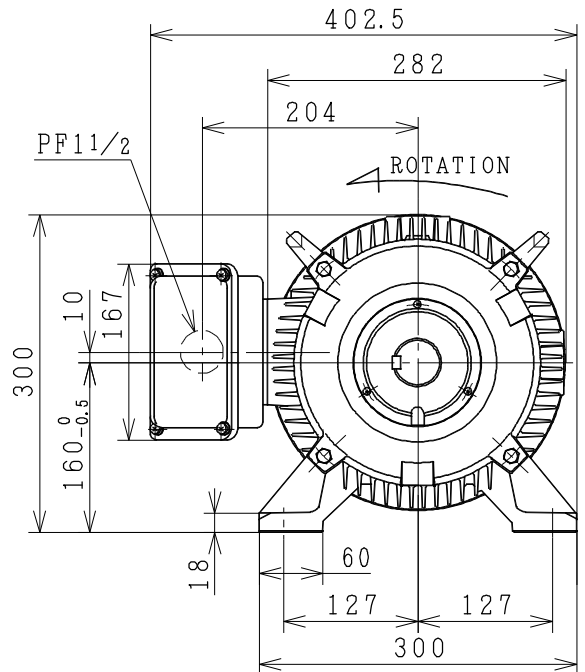
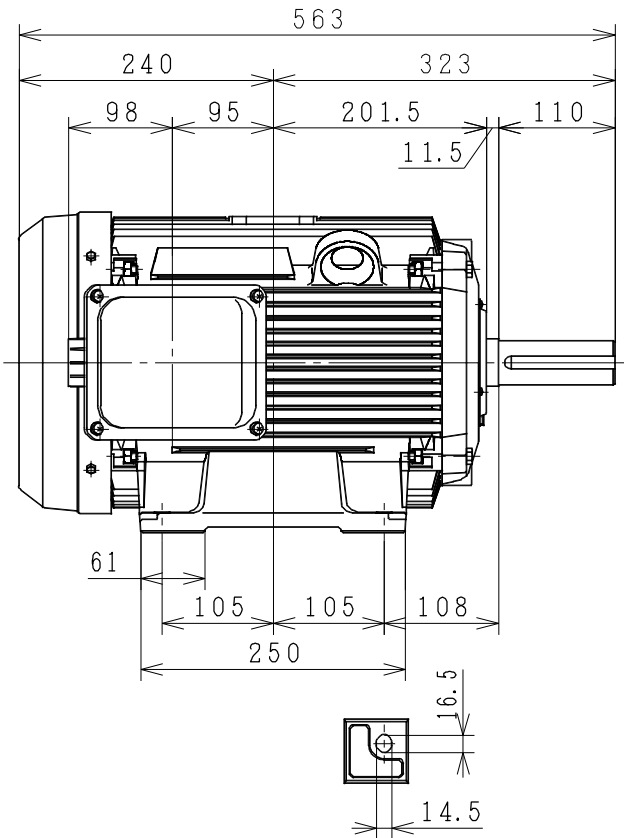

PROTECTION: IP55

PROJECTION

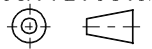

CUSTOMER			QTY.	ORDER No.	WORK No.	REV.
DWN. P. TIANCHAI	21-09-12	} DIMENSIONS	HITACHI Hitachi Industrial Technology (Thailand), Ltd.		HITT WORKS DWG. No.	SH.
CHKD. W. THAWAT					4HTD02385	
APPD. T. SHIMOZONO						

FRAME SIZE TFOF (D) -160M (TMLR)

HITACHI

MANUFACTURER'S TEST REPORT OF INDUCTION MOTOR

MESSRS		ORDER No	
--------	--	----------	--

SPECIFICATION FOR MOTOR

OUT PUT(HP)	20	POLES	2	TYPE-FORM	TFO-KK
FREQUENCY(HZ)	50/50	VOLTAGE(V)	380/415	CURRENT(A)	28/28
PHASES	3	RATING	S1	INSULATION	F
STANDARD	JEC-2137-2000	SECONDARY VOLTAGE(V)	—	SECONDARY CURRENT(A)	—
COOLING	IC411	PROTECTION	IP55	SPEED(min ⁻¹)	2900/2910

MFG No	FREQUENCY (HZ)	NO-LOAD TEST			LOCKED ROTOR TEST		
		VOLTAGE(V)	CURRENT(A)	INPUT(W)	VOLTAGE(V)	CURRENT(A)	INPUT(W)
	50	380	8.78	560.0	66.8	28.0	1540.0
	50	415	13.12	712.0	66.8	28.0	1540.0

(3) WINDINGS RESISTANCE (BETWEEN LINES) STATOR 115°C 0.53815(Ω)

(4) LOAD CHARACTERISTICS

LOAD(%)	CURRENT(A)	EFFICIENCY(%)	POWERFACTOR(%)	SLIP(%)
25	11.08/14.31	85.7/81.4	60.0/44.7	0.6/0.5
50	15.79/17.74	90.4/88.2	79.9/66.6	1.2/1.1
75	21.61/22.38	91.1/89.9	86.8/77.6	1.8/1.7
100	28.14/27.80	90.6/90.1	89.4/83.1	2.5/2.3
125	35.33/33.85	89.5/89.6	90.1/85.8	3.3/3.0

(5) MAXIMUM OUT PUT(%) STARTING CURRENT(A) STARTING TORQUE(%)

243/285 208.5/232.5 300/374

(6) TEMPERATURE RISE TEST (R)-RESISTANCE METHOD

STATOR WINDINGS(K)	FRAME(K)	ROTOR WINDINGS(K)
73.0/73.0 (R)	27.0/27.0	-

(7) INSULATION RESISTANCE BY 500V MEGGER

100MΩ

(8) WITHSTAND STATOR WINDINGS TO CORE

1900V 1MIN WITHSTOOD

VOLTAGE TEST ROTOR WINDINGS TO CORE

—V 1MIN WITHSTOOD

(9) CONSTRUCTION, DIMENSION, PAINTING, OTHER PARTS

SATISFACTORY

HITACHI INDUSTRIAL TECHNOLOGY (THAILAND) LTD.	CHECKED BY	C.ANAN
	DATE	06-JUNE.-2015

REP.No.RP10068

Three Phase Induction Motor Characteristic Curve

Hitachi Industrial Technology(Thailand),Ltd

Power (HP)	20
Pole	2
Type-Form	TFO-KK, VTFO-KK
Voltage (V)	380
Frequency (Hz)	50
Protection	IP44, IP55

Load (%)	0	25	50	75	100	125
Current(A)	8.78	11.08	15.79	21.61	28.14	35.30
Efficiency(%)	0	85.7	90.4	91.1	90.6	89.5
Power factor(%)	9.7	60.0	79.9	86.8	89.4	90.1
Slip (%)	0	0.6	1.2	1.8	2.5	3.3

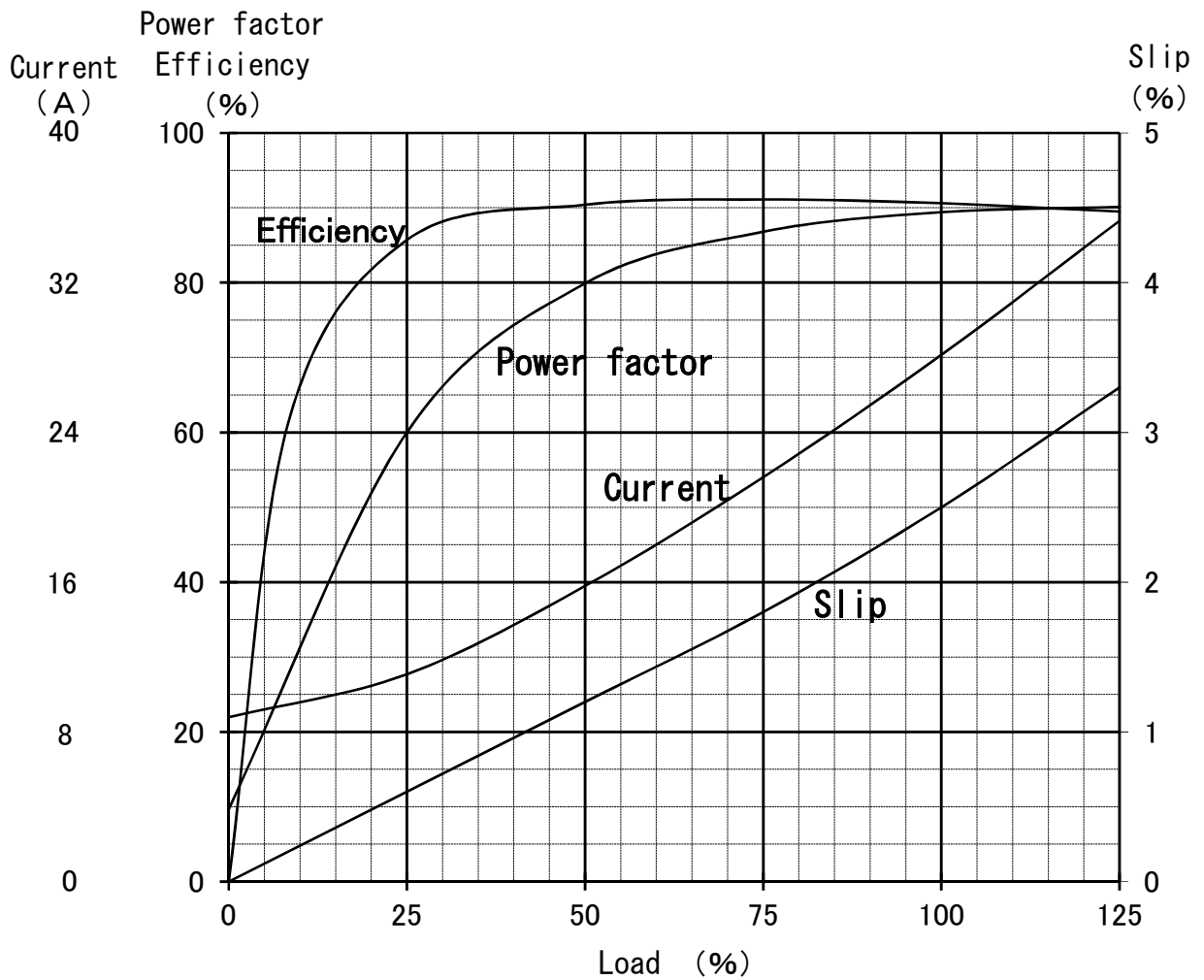

20HP (V) TF0-KK 2P
380/415V 50Hz
IP44/IP55

