

# THREE-PHASE INDUCTION MOTOR

OUTPUT	TYPE	FORM	RATING	VOLTAGE (V)	FREQ. (Hz)	SYNC. SPEED (min <sup>-1</sup> )	POLES	TH. CLASS	MASS (kg)
5HP	TF0	K	S1	220/380	50	3000	2	B	30
5HP	TF0	K	S1	220/380	50	1500	4	B	32
3HP	TF0	K	S1	220/380	50	1000	6	B	28

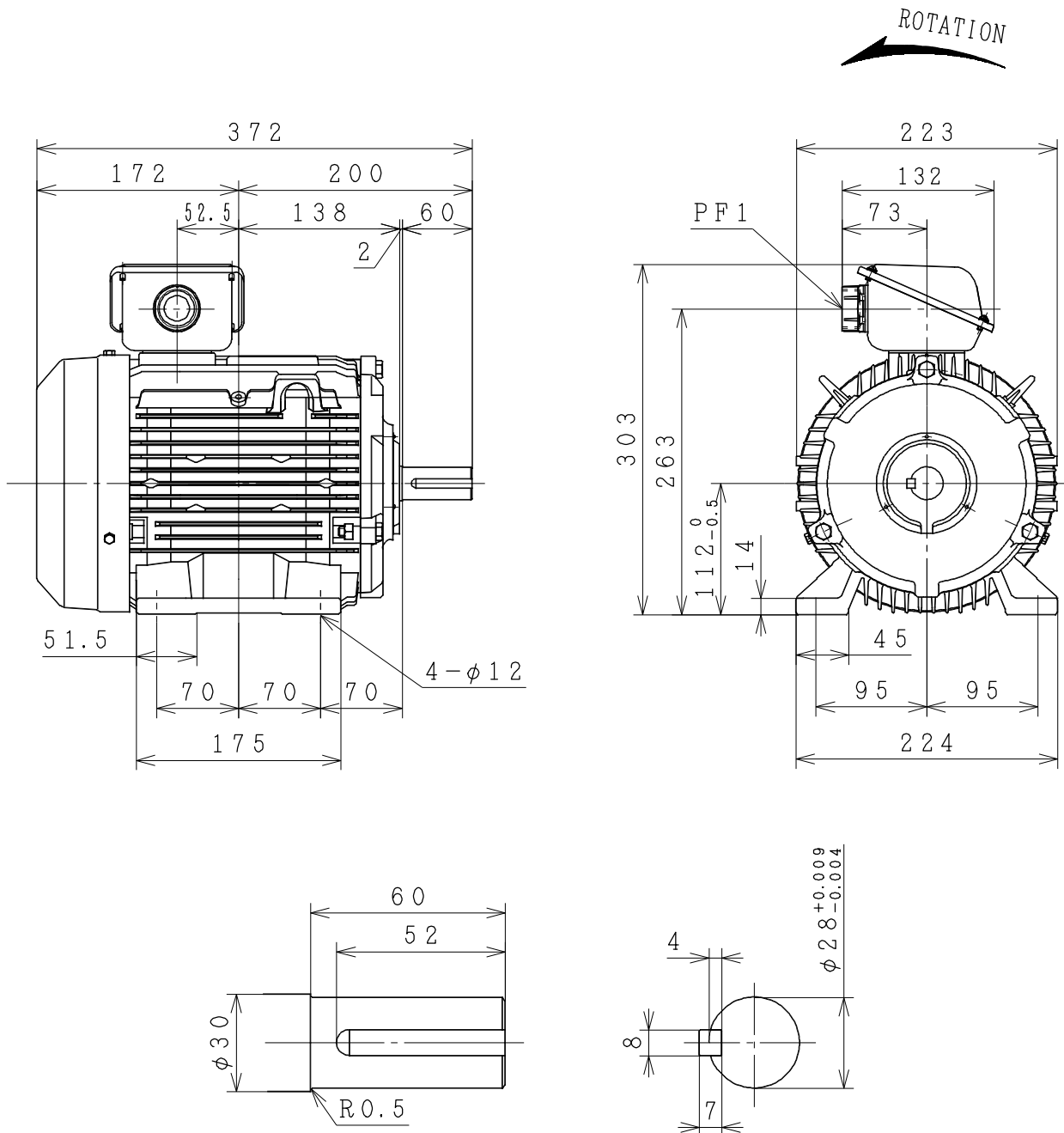

PROTECTION : IP55

PROJECTION

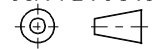

CUSTOMER	QTY.	ORDER No.	WORK No.	REV.
DIMENSIONS	<b>HITACHI</b> Hitachi Industrial Technology (Thailand), Ltd.		HITT WORKS DWG. No. 4HTD03364	SH.

FRAME SIZE TF0D-112M(TMHD)

# THREE-PHASE INDUCTION MOTOR

OUTPUT	TYPE	FORM	RATING	VOLTAGE (V)	FREQ. (Hz)	SYNC. SPEED (min <sup>-1</sup> )	POLES	INS. CLASS	MASS (kg)
5HP	TFO	K	S1	220/380V	50	3000	2	F	30
5HP	TFO	K	S1	220/380V	50	1500	4	F	32
3HP	TFO	K	S1	220/380V	50	1000	6	F	29

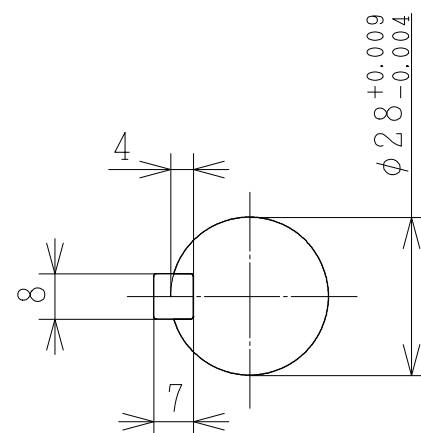
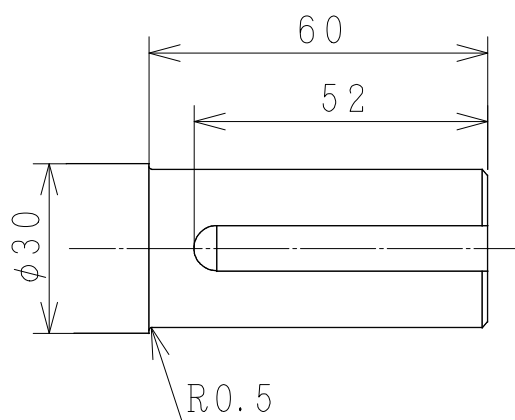
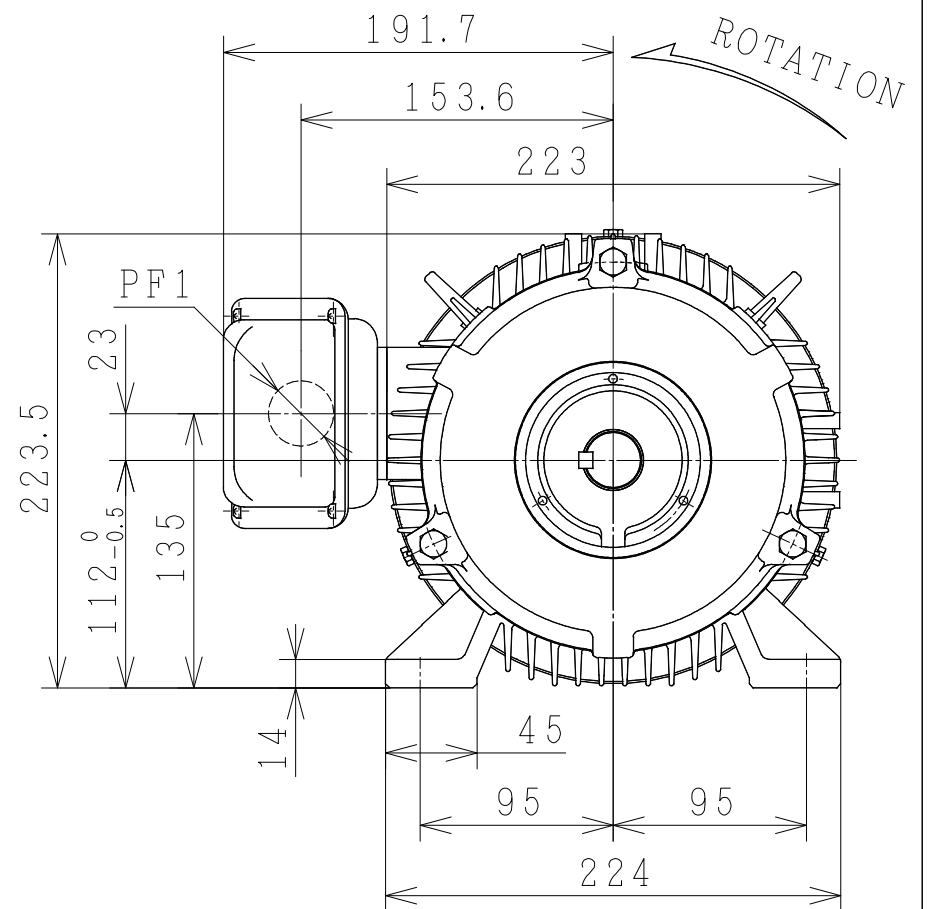
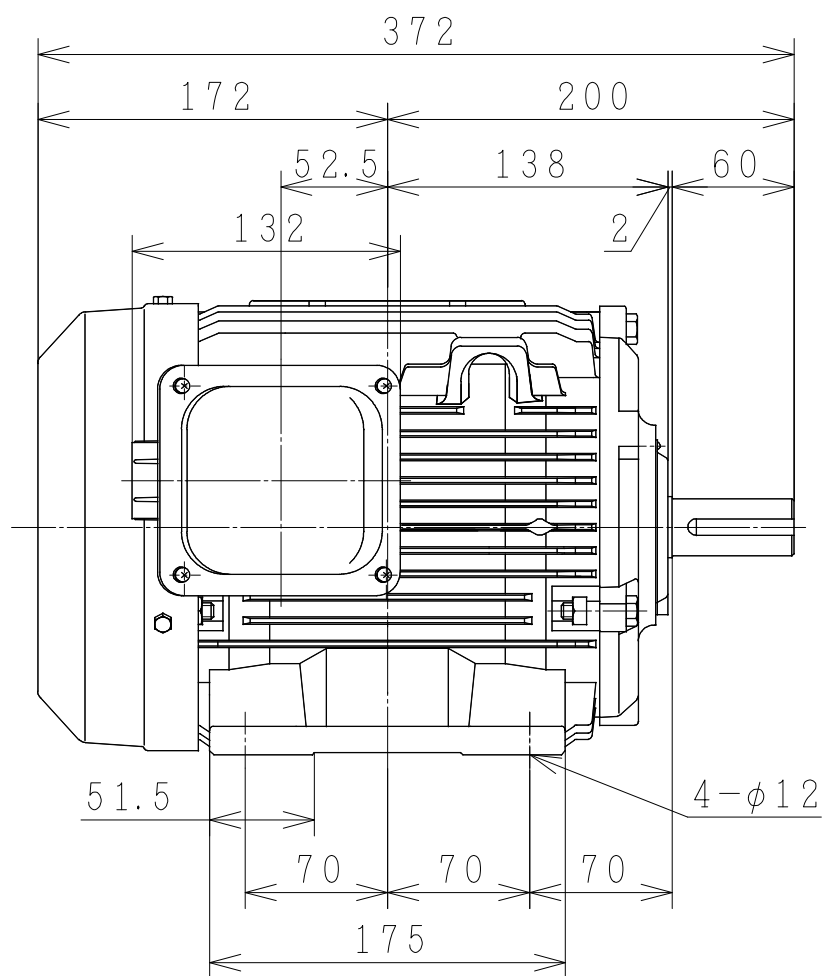

PROTECTION: IP55

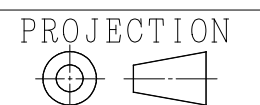

CUSTOMER			QTY.	ORDER NO.	WORK NO.	REV.
DWN	P. Tianchai	21-Sep-2012				SH.
CHKD	W. THAWAT	§	DIMENSIONS		<b>HITACHI</b> Hitachi Industrial Technology (Thailand), Ltd.	4HTD02378
APPD	T. SHIMOZONO		FRAME SIZE	TFOD-112M (TMLR)		

# HITACHI

## MANUFACTURER'S TEST REPORT OF INDUCTION MOTOR

MESSRS		ORDER No	
--------	--	----------	--

### SPECIFICATION FOR MOTOR

OUT PUT(HP)	5	POLES	2	TYPE-FORM	TFO-K
FREQUENCY(HZ)	50/50	VOLTAGE(V)	220/380	CURRENT(A)	12.5/7.4
PHASES	3	RATING	S1	INSULATION	F
STANDARD	JEC-2137-2000	SECONDARY VOLTAGE(V)	—	SECONDARY CURRENT(A)	—
COOLING	IC411	PROTECTION	IP55	SPEED(min <sup>-1</sup> )	2860/2860

MFG No	FREQUENCY (HZ)	(1)NO-LOAD TEST			(2)LOCKED ROTOR TEST		
		VOLTAGE(V)	CURRENT(A)	INPUT(W)	VOLTAGE(V)	CURRENT(A)	INPUT(W)
	50	220	3.74	226.0	39.6	12.1	416.0
	50	380	2.16	226.0	68.6	7.0	416.0

(3)WINDINGS RESISTANCE (BETWEEN LINES) STATOR 115°C 1.21070/3.63214(Ω)

#### (4)LOAD CHARACTERISTICS

LOAD(%)	CURRENT(A)	EFFICIENCY(%)	POWER FACTOR(%)	SLIP(%)
25	4.83/2.79	78.5/78.5	64.2/64.2	1.2/1.2
50	6.94/4.01	85.0/85.0	82.7/82.7	2.4/2.4
75	9.55/5.52	85.8/85.8	89.2/89.2	3.7/3.7
100	12.55/7.25	84.7/84.7	91.7/91.7	5.2/5.2
125	15.95/9.21	82.5/82.5	92.4/92.4	6.9/6.9

(5)MAXIMUM OUT PUT(%) STARTING CURRENT(A) STARTING TORQUE(%)

201/201 90.0/52.0 269/269

(6)TEMPERATURE RISE TEST (R)-RESISTANCE METHOD

STATOR WINDINGS(K)	FRAME(K)	ROTOR WINDINGS(K)
72.0/72.0 (R)	23.5/23.5	—

(7)INSULATION RESISTANCE BY 500V MEGGER

100MΩ

(8)WITHSTAND STATOR WINDINGS TO CORE 1900V 1MIN WITHSTOOD  
VOLTAGE TEST ROTOR WINDINGS TO CORE — V 1MIN WITHSTOOD

(9)CONSTRUCTION, DIMENSION, PAINTING, OTHER PARTS SATISFACTORY

HITACHI INDUSTRIAL TECHNOLOGY (THAILAND) LTD.	CHECKED BY	T.SHIMOZONO
	DATE	25-MAY-2015

REP.No.RP10057

### Three Phase Induction Motor Characteristic Curve

Hitachi Industrial Technology(Thailand),Ltd

Power (HP)	5
Pole	2
Type-Form	TFO-K, VTFO-K
Voltage (V)	380
Frequency (Hz)	50
Protection	IP44, IP55

Load (%)	0	25	50	75	100	125
Current (A)	2.16	2.79	4.01	5.52	7.25	9.21
Efficiency (%)	0	78.5	85.0	85.8	84.7	82.5
Power factor (%)	15.9	64.2	82.7	89.2	91.7	92.4
Slip (%)	0	1.2	2.4	3.7	5.2	6.9

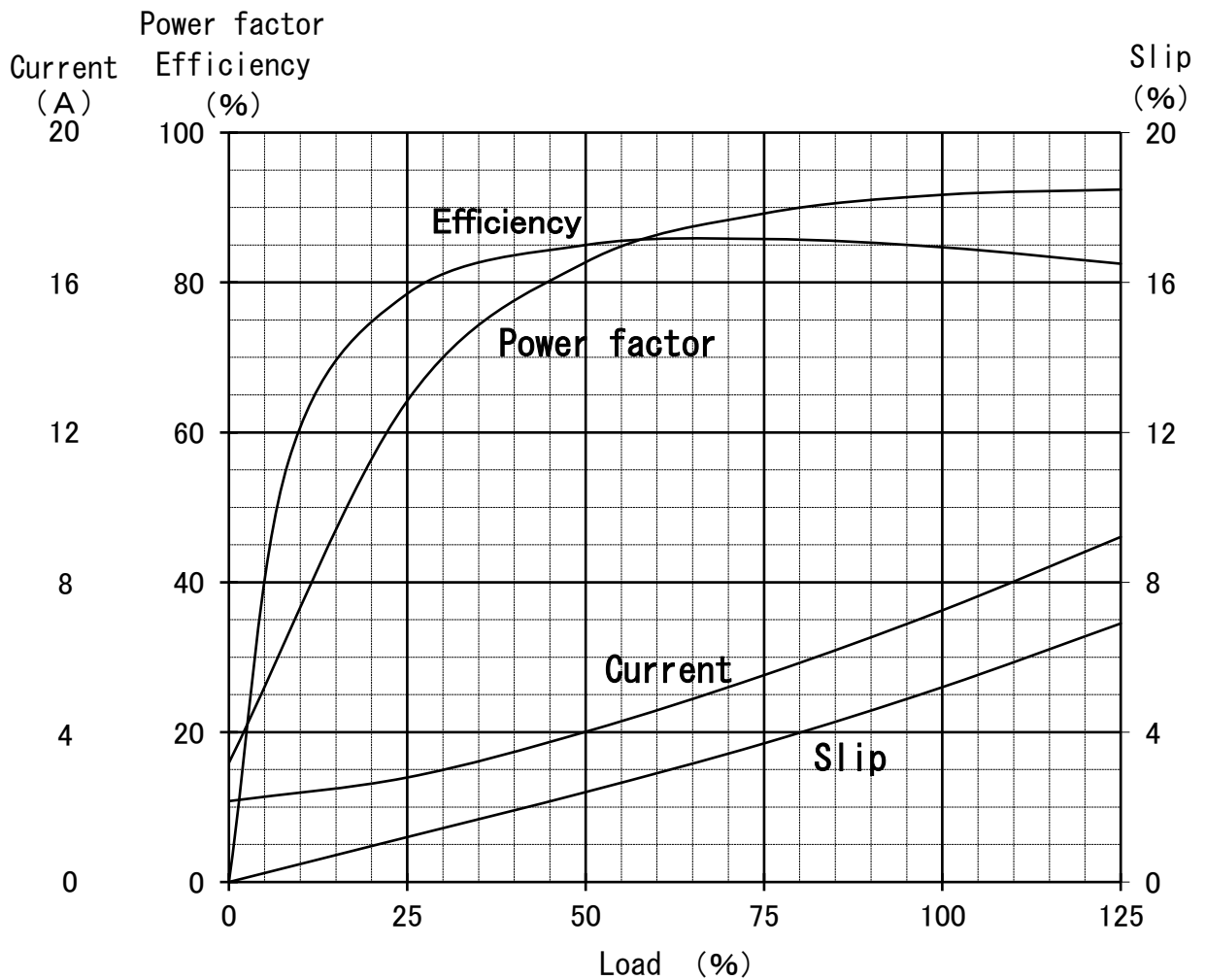

# Speed-Torque, Current Curve

5HP (V) TF0-K 2P  
220/380V 50Hz  
IP44/IP55

