

THREE-PHASE INDUCTION MOTOR

OUTPUT	TYPE	FORM	RATING	VOLTAGE (V)	FREQ. (Hz)	SYNC. SPBBD (min ⁻¹)	POLES	TH. CLASS	MASS (kg)
2HP	TFO	K	S1	220/380	50	3000	2	F	15
3HP	TFO	K	S1	220/380	50	3000	2	F	16
2HP	TFO	K	S1	220/380	50	1500	4	F	16
1HP	TFO	K	S1	220/380	50	1000	6	F	16

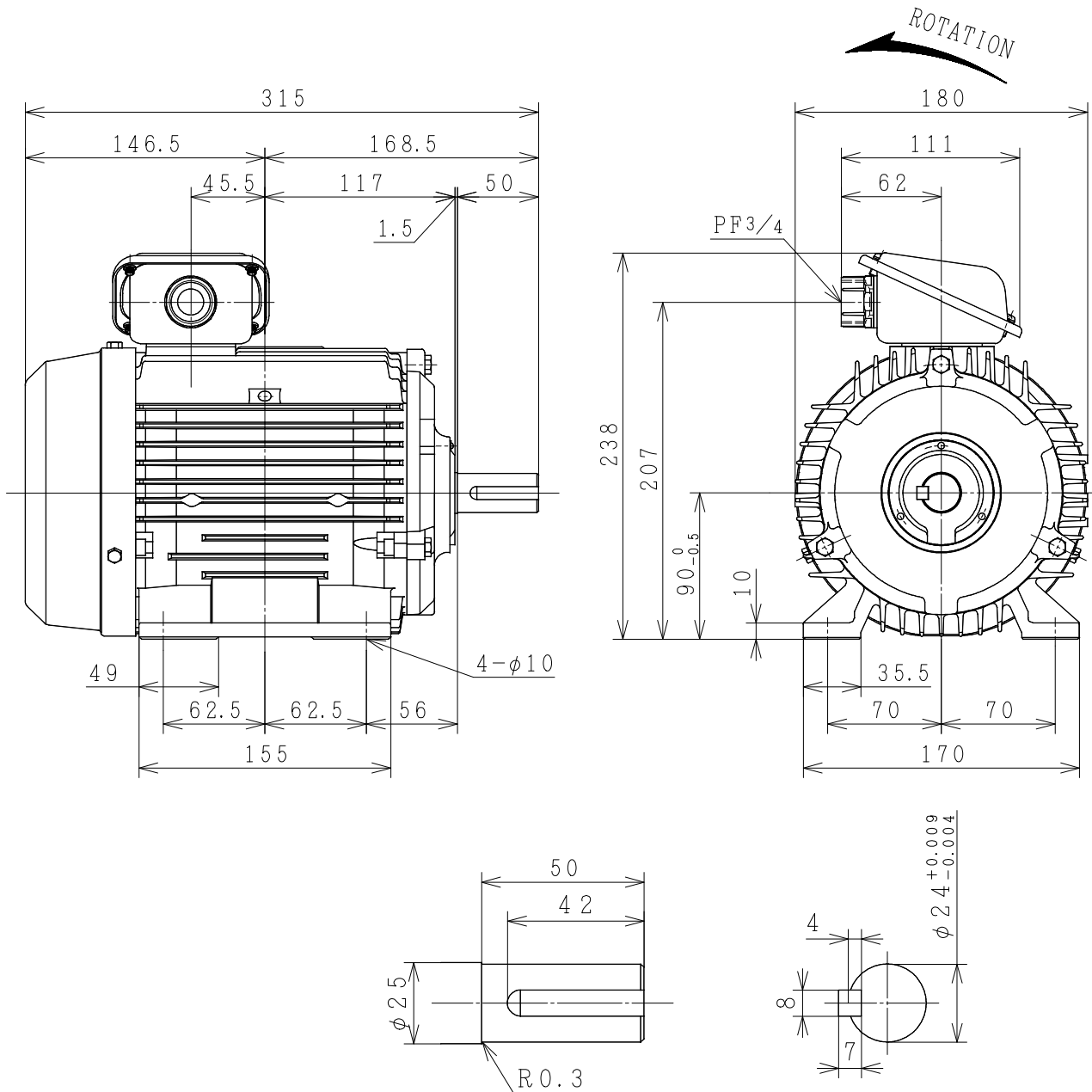

PROTECTION : IP55

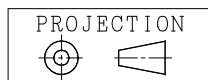

CUSTOMER	QTY.	ORDER No.	WORK No.	REV.
DIMENSIONS	HITACHI Hitachi Industrial Technology (Thailand), Ltd.		HITT WORKS DWG. No. 4HTD03360	SH.

FRAME SIZE TFOD-90L (TMHD)

THREE-PHASE INDUCTION MOTOR

OUTPUT	TYPE	FORM	RATING	VOLTAGE (V)	FREQ. (Hz)	SYNC. SPEDD (min ⁻¹)	POLES	INS. CLASS	MASS (kg)
2HP	TFO	K	S1	220/380	50	3000	2	F	15
3HP	TFO	K	S1	220/380	50	3000	2	F	16
2HP	TFO	K	S1	220/380	50	1500	4	F	16
1HP	TFO	K	S1	220/380	50	1000	6	F	16

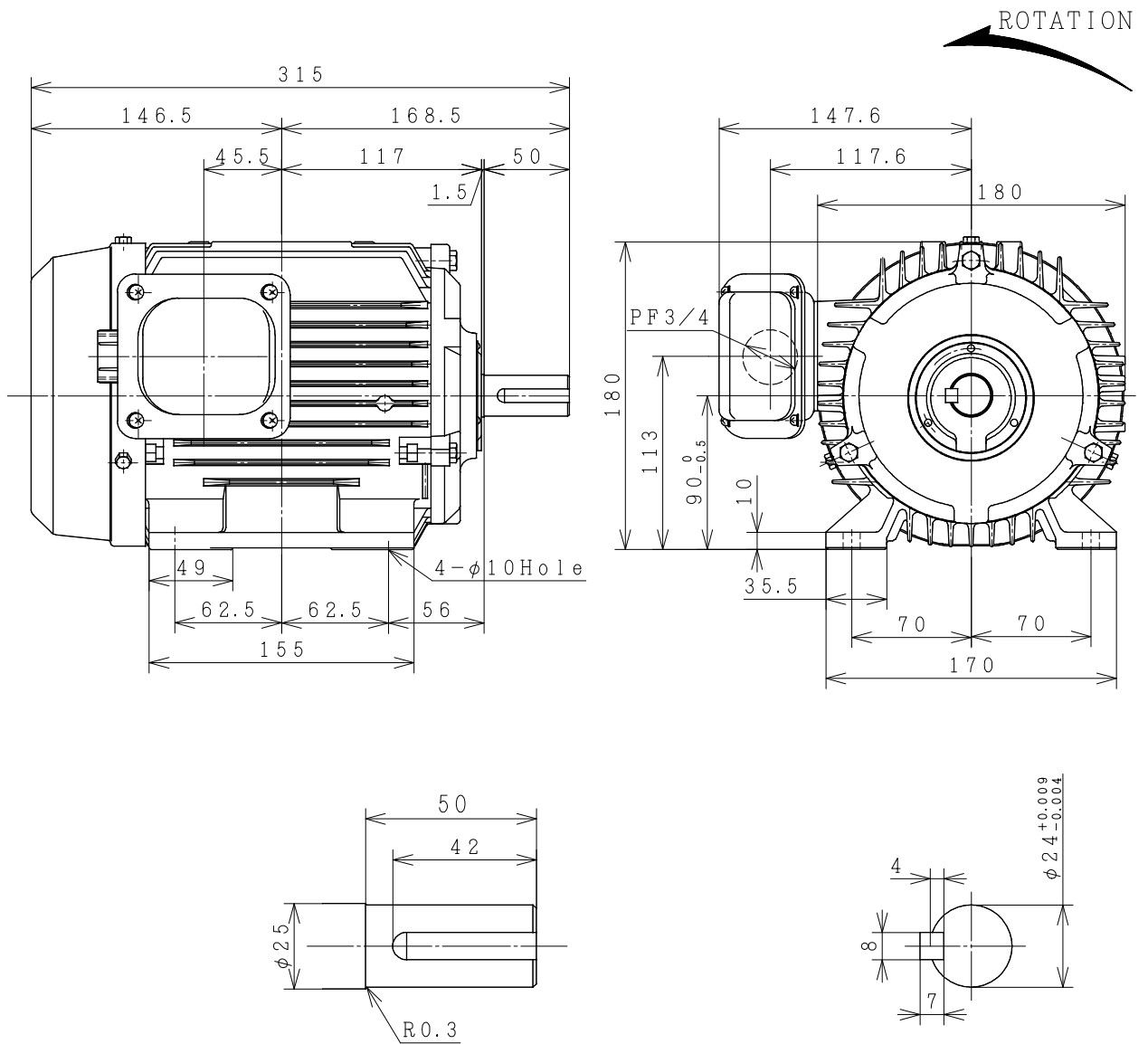

PROTECTION: IP55

PROJECTION

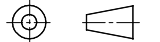

CUSTOMER			QTY.	ORDER No.	WORK No.	REV.	
DWN.	S. Sakda	21-Jun-2015	<div style="font-size: 2em; font-weight: bold;">DIMENSIONS</div>		HITT WORKS DWG. No.	SH.	
CHKD.	W. Thawat				<div style="font-weight: bold;">HITACHI</div> <small>Hitachi Industrial Technology (Thailand), Ltd.</small>	<div style="font-size: 1.5em; font-weight: bold;">4HTD02541</div>	
APPD.	T. Shimozone						
FRAME SIZE			TFOD-90L (TMLR)				

HITACHI

MANUFACTURER'S TEST REPORT OF INDUCTION MOTOR

MESSRS		ORDER No	
--------	--	----------	--

SPECIFICATION FOR MOTOR

OUT PUT(HP)	1	POLES	6	TYPE-FORM	TFO-K
FREQUENCY(HZ)	50/50	VOLTAGE(V)	220/380	CURRENT(A)	3.8/2.2
PHASES	3	RATING	S1	INSULATION	F
STANDARD	JEC-2137-2000	SECONDARY VOLTAGE(V)	—	SECONDARY CURRENT(A)	—
COOLING	IC411	PROTECTION	IP55	SPEED(min ⁻¹)	930/930

MFG No	FREQUENCY (HZ)	NO-LOAD TEST			LOCKED ROTOR TEST		
		VOLTAGE(V)	CURRENT(A)	INPUT(W)	VOLTAGE(V)	CURRENT(A)	INPUT(W)
	50	220	2.60	127.0	47.69	2.60	142.0
	50	380	1.50	127.0	82.6	1.50	142.0

(3) WINDINGS RESISTANCE (BETWEEN LINES) STATOR 115°C 9.98123/29.94372(Ω)

(4) LOAD CHARACTERISTICS

LOAD(%)	CURRENT(A)	EFFICIENCY(%)	POWERFACTOR(%)	SLIP(%)
25	2.65/1.53	56.4/56.4	33.1/33.1	2.0/2.0
50	2.86/1.65	68.6/68.6	50.4/50.4	4.2/4.2
75	3.24/1.87	71.2/71.2	64.1/64.1	6.8/6.8
100	3.85/2.22	69.5/69.5	73.7/73.7	10.1/10.1
125	4.81/2.78	64.1/64.1	79.9/79.9	15.2/15.2

(5) MAXIMUM OUT PUT(%) STARTING CURRENT(A) STARTING TORQUE(%)

141/141 14.9/8.6 218/218

(6) TEMPERATURE RISE TEST (R)-RESISTANCE METHOD

STATOR WINDINGS(K)	FRAME(K)	ROTOR WINDINGS(K)
61.5/61.5 (R)	38.5/38.5	-

(7) INSULATION RESISTANCE BY 500V MEGGER

100MΩ

(8) WITHSTAND VOLTAGE TEST STATOR WINDINGS TO CORE ROTOR WINDINGS TO CORE

1900V 1MIN WITHSTOOD
— V 1MIN WITHSTOOD

(9) CONSTRUCTION, DIMENSION, PAINTING, OTHER PARTS

SATISFACTORY

HITACHI INDUSTRIAL TECHNOLOGY (THAILAND) LTD.	CHECKED BY	M.KAMIZONO
	DATE	11-JUN-2015

REP.No.RP30030

Three Phase Induction Motor Characteristic Curve

Hitachi Industrial Technology(Thailand),Ltd

Power (HP)	1
Pole	6
Type-Form	TFO-K , VTFO-K
Voltage (V)	380
Frequency (Hz)	50
Protection	IP44 , IP55

Load (%)	0	25	50	75	100	125
Current(A)	1.50	1.53	1.65	1.87	2.22	2.78
Efficiency(%)	0	56.4	68.6	71.2	69.5	64.1
Power factor(%)	12.9	33.1	50.4	64.1	73.7	79.9
Slip (%)	0	2.0	4.2	6.8	10.1	15.2

