

# THREE-PHASE INDUCTION MOTOR

OUTPUT	TYPE	FORM	RATING	VOLTAGE (V)	FREQ. (Hz)	SYNC. SPEED (min <sup>-1</sup> )	POLES	INS. CLASS	MASS (kg)
1HP	TFO	K	S1	220/380	50	3000	2	F	10
1HP	TFO	K	S1	220/380	50	1500	4	F	12
1/2HP	TFO	K	S1	220/380	50	1000	6	F	12

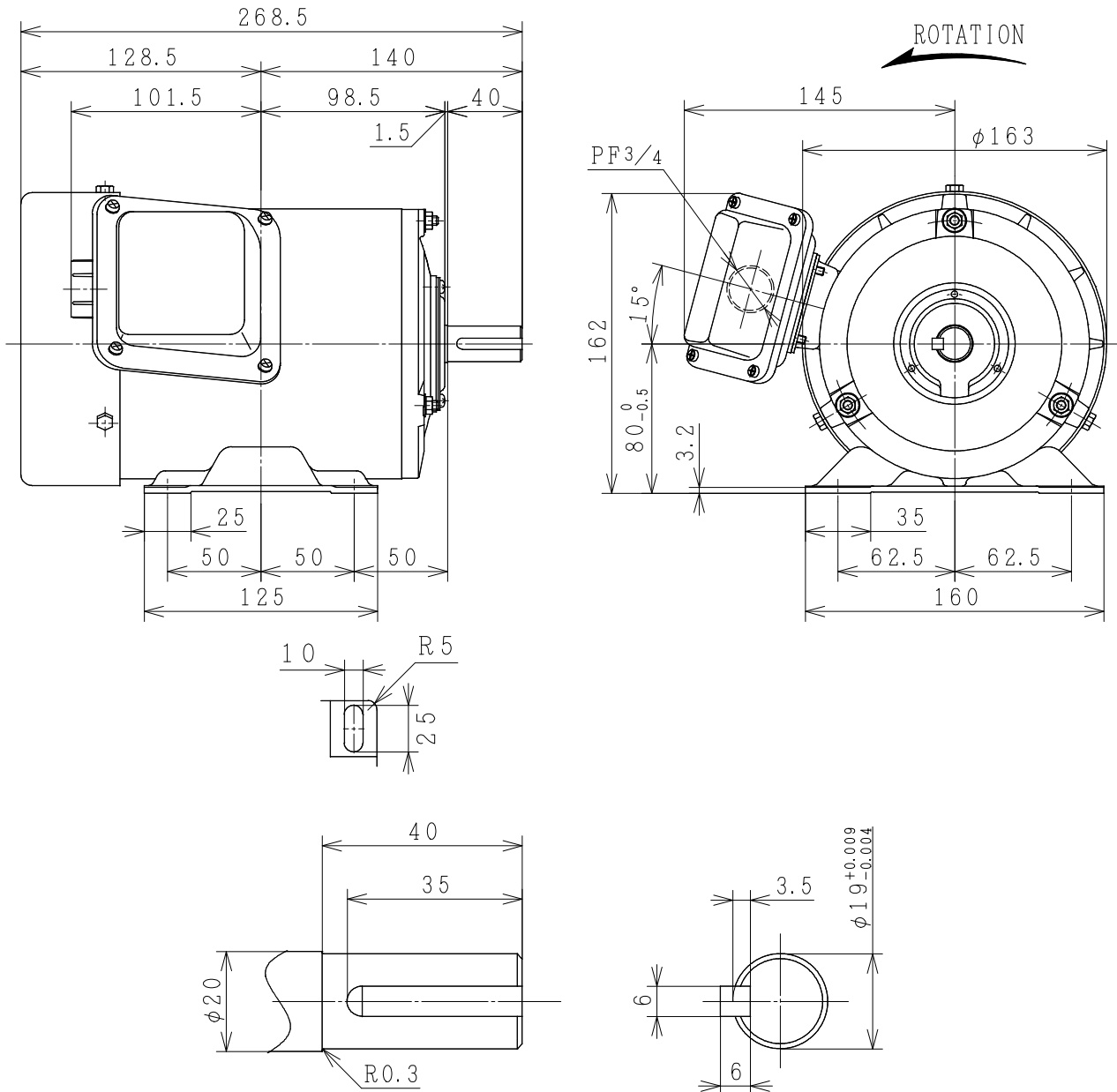

PROTECTION: IP55

PROJECTION

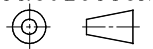

CUSTOMER			QTY.	ORDER No.	WORK No.	REV.
DWN.	W. KANCHIT	12-12-12	<div style="display: flex; align-items: center; justify-content: center;"> <div style="text-align: center;"> <h2 style="margin: 0;">DIMENSIONS</h2> <p style="font-size: 8px; margin: 0;">Hitachi Industrial Technology (Thailand), Ltd.</p> </div> </div>			SH.
CHKD.	W. THAWAT					HITT WORKS DWG. No.
APPD.	T. Shimozone					4HTD02466
FRAME SIZE TFOB-80M (TMLR)						

# THREE-PHASE INDUCTION MOTOR

OUTPUT	TYPE	FORM	RATING	VOLTAGE (V)	FREQ. (Hz)	SYNC. SPEED (min <sup>-1</sup> )	POLES	TH. CLASS	MASS (kg)
1HP	TFO	K	S1	220/380	50	3000	2	F	10
1HP	TFO	K	S1	220/380	50	1500	4	F	12
1/2HP	TFO	K	S1	220/380	50	1000	6	F	12

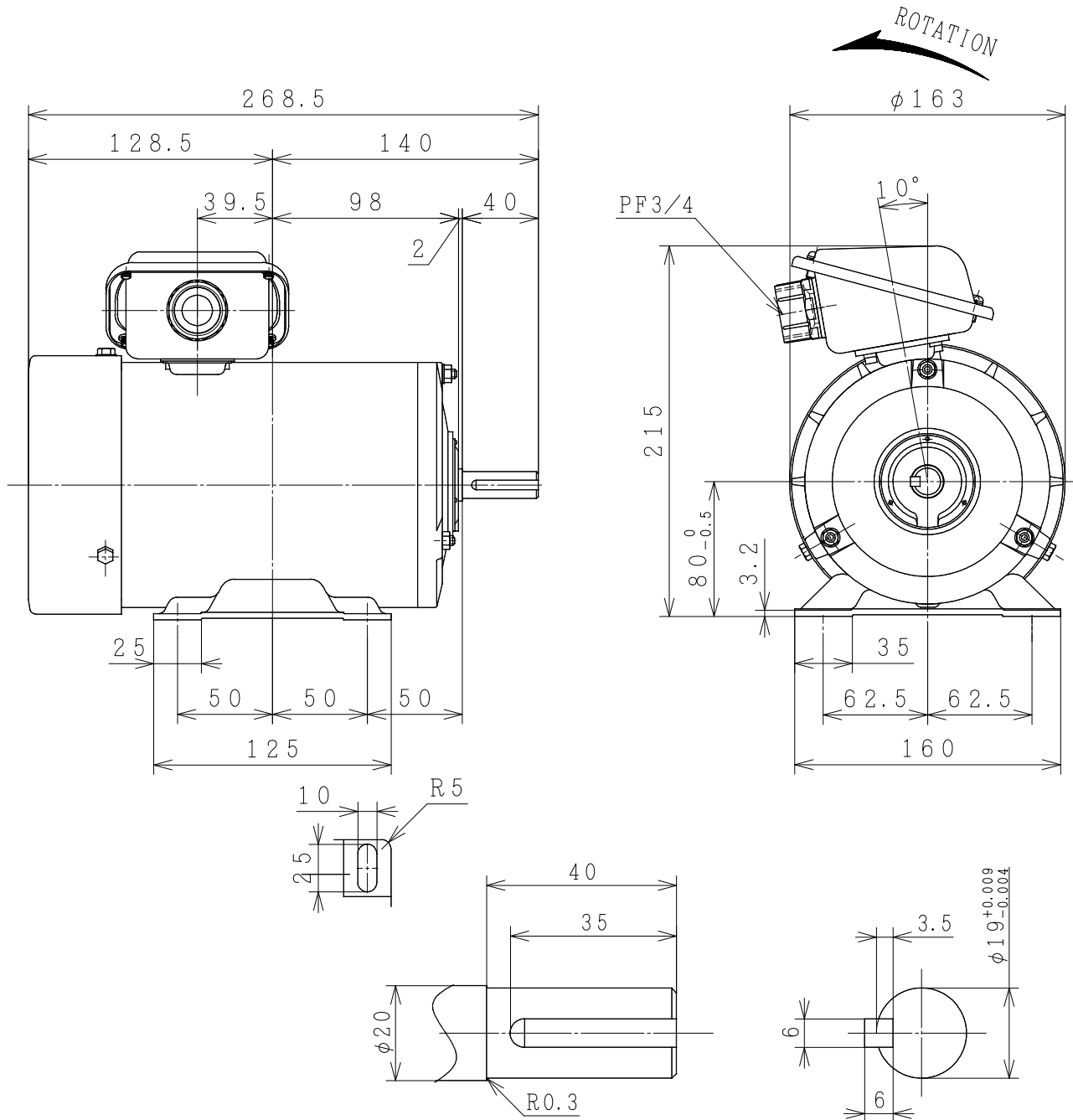

PROTECTION : IP55

PROJECTION

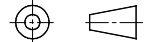

CUSTOMER	QTY.	ORDER No.	WORK No.	REV.
<h1 style="margin: 0;">DIMENSIONS</h1>	<b>HITACHI</b> Hitachi Industrial Technology (Thailand), Ltd.		HITT WORKS DWG. No. <b>4HTD03358</b>	SH.
	FRAME SIZE TFOB-80M (TMHD)			

# HITACHI

## MANUFACTURER'S TEST REPORT OF INDUCTION MOTOR

MESSRS		ORDER No	
--------	--	----------	--

### SPECIFICATION FOR MOTOR

OUT PUT(HP)	1/2	POLES	6	TYPE-FORM	TFO-K
FREQUENCY(HZ)	50	VOLTAGE(V)	220/380	CURRENT(A)	2.0/1.2
PHASES	3	RATING	S1	INSULATION	F
STANDARD	JEC-2137-2000	SECONDARY VOLTAGE(V)	—	SECONDARY CURRENT(A)	—
COOLING	IC411	PROTECTION	IP55	SPEED(min <sup>-1</sup> )	940/940

MFG No	FREQUENCY (HZ)	NO-LOAD TEST			LOCKED ROTOR TEST		
		VOLTAGE(V)	CURRENT(A)	INPUT(W)	VOLTAGE(V)	CURRENT(A)	INPUT(W)
	50	220	1.48	78	62.5	2.0	153.0
	50	380	0.86	78	108.4	1.2	153.0

(3) WINDINGS RESISTANCE (BETWEEN LINES) STATOR 115°C 18.63118/55.89353(Ω)

#### (4) LOAD CHARACTERISTICS

LOAD(%)	CURRENT(A)	EFFICIENCY(%)	POWERFACTOR(%)	SLIP(%)
25	1.50/0.87	52.8/52.8	32.7/32.7	1.5/1.5
50	1.61/0.93	66.5/66.5	49.2/49.2	3.2/3.2
75	1.78/1.03	70.6/70.6	62.5/62.5	5.1/5.1
100	2.06/1.19	70.5/70.5	72.3/72.3	7.5/7.5
125	2.45/1.42	67.6/67.6	79.0/79.0	10.6/10.6

(5) MAXIMUM OUT PUT(%) STARTING CURRENT(A) STARTING TORQUE(%)

160/160 8.8/5.1

#### (6) TEMPERATURE RISE TEST (R)-RESISTANCE METHOD

STATOR WINDINGS(K)	FRAME(K)	ROTOR WINDINGS(K)
67.5 (R)	46.0	—

(7) INSULATION RESISTANCE BY 500V MEGGER

100MΩ

(8) WITHSTAND STATOR WINDINGS TO CORE

1900V 1MIN WITHSTOOD

VOLTAGE TEST ROTOR WINDINGS TO CORE

— V 1MIN WITHSTOOD

(9) CONSTRUCTION, DIMENSION, PAINTING, OTHER PARTS

SATISFACTORY

HITACHI INDUSTRIAL TECHNOLOGY (THAILAND) LTD.	CHECKED BY	M.KAMIZONO
	DATE	10-JUNE-2015

REP.No.RP30027

### Three Phase Induction Motor Characteristic Curve

Hitachi Industrial Technology(Thailand),Ltd

Power (HP) 1/2  
 Pole 6  
 Type-Form TFO-K , VTFO-K  
 Voltage (V) 380  
 Frequency (Hz) 50  
 Protection IP44 , IP55

Load (%)	0	25	50	75	100	125
Current (A)	0.86	0.87	0.93	1.03	1.19	1.42
Efficiency (%)	0	52.8	66.5	70.6	70.5	67.6
Power factor (%)	13.8	32.7	49.2	62.5	72.3	79.0
Slip (%)	0	1.5	3.2	5.1	7.5	10.6

