

GEAR MOTOR

| OUTPUT (kW) | TYPE | FORM | RATING | VOLTAGE (V) | FREQ. (Hz) | SPEED (min ⁻¹) | POLES | TH. CLASS | MASS (kg) |
|-------------|------|------|--------|-------------|------------|----------------------------|-------|-----------|-----------|
| 2.2 | TFOG | K | S1 | 220/380 | 50 | 50 | 4 | F | 48 |

MODEL NO.

GH48-220-30

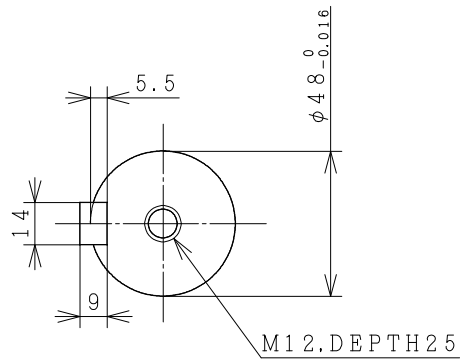
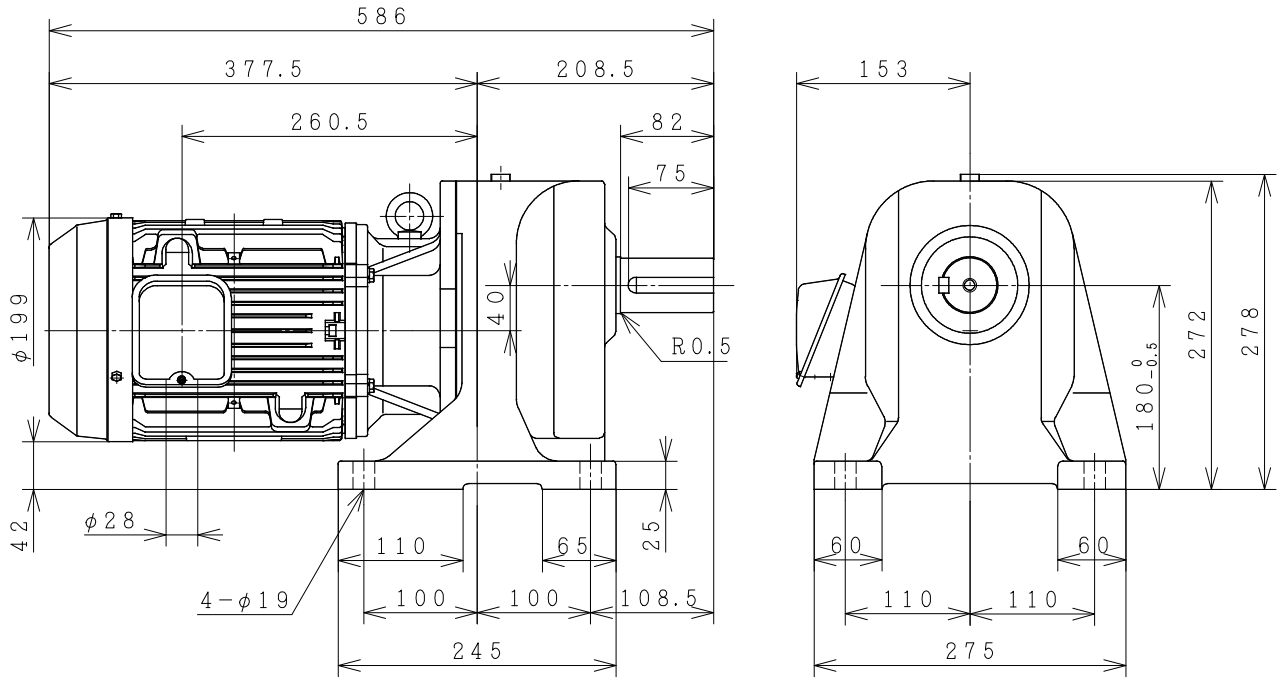

PROJECTION

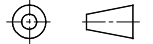

| | | | | | | | |
|----------------------------|-------------|-------------|---|-----------|----------|---------------------|-----|
| CUSTOMER | | | QTY. | ORDER No. | WORK No. | REV. | |
| DWN. | D. ITTIDECH | 09-Jul-2015 | <div style="display: flex; justify-content: space-around; align-items: center;"> <div style="font-size: 2em; font-weight: bold;">DIMENSIONS</div> <div style="text-align: center;"> HITACHI <small>Hitachi Industrial Technology (Thailand), Ltd.</small> </div> <div style="font-size: 1.5em; font-weight: bold;">4HTD03135</div> </div> | | | HITT WORKS DWG. No. | SH. |
| CHKD. | M. KAMIZONO | S | | | | | |
| APPD. | M. KAMIZONO | | | | | | |
| FRAME SIZE (GH) 2.2kW 1/30 | | | | | | | |