

GEAR MOTOR

OUTPUT (HP)	MODEL SYMBOL	VOLTAGE (V)	FREQ. (Hz)	SPEED (min ⁻¹)	POLES	TH. CLASS	MASS (kg)
3	GH38-220-5	220/380	50	300	4	F	34
3	GH38-220-10	220/380	50	150	4	F	35
3	GH38-220-15	220/380	50	100	4	F	35
3	GH38-220-20	220/380	50	75	4	F	35

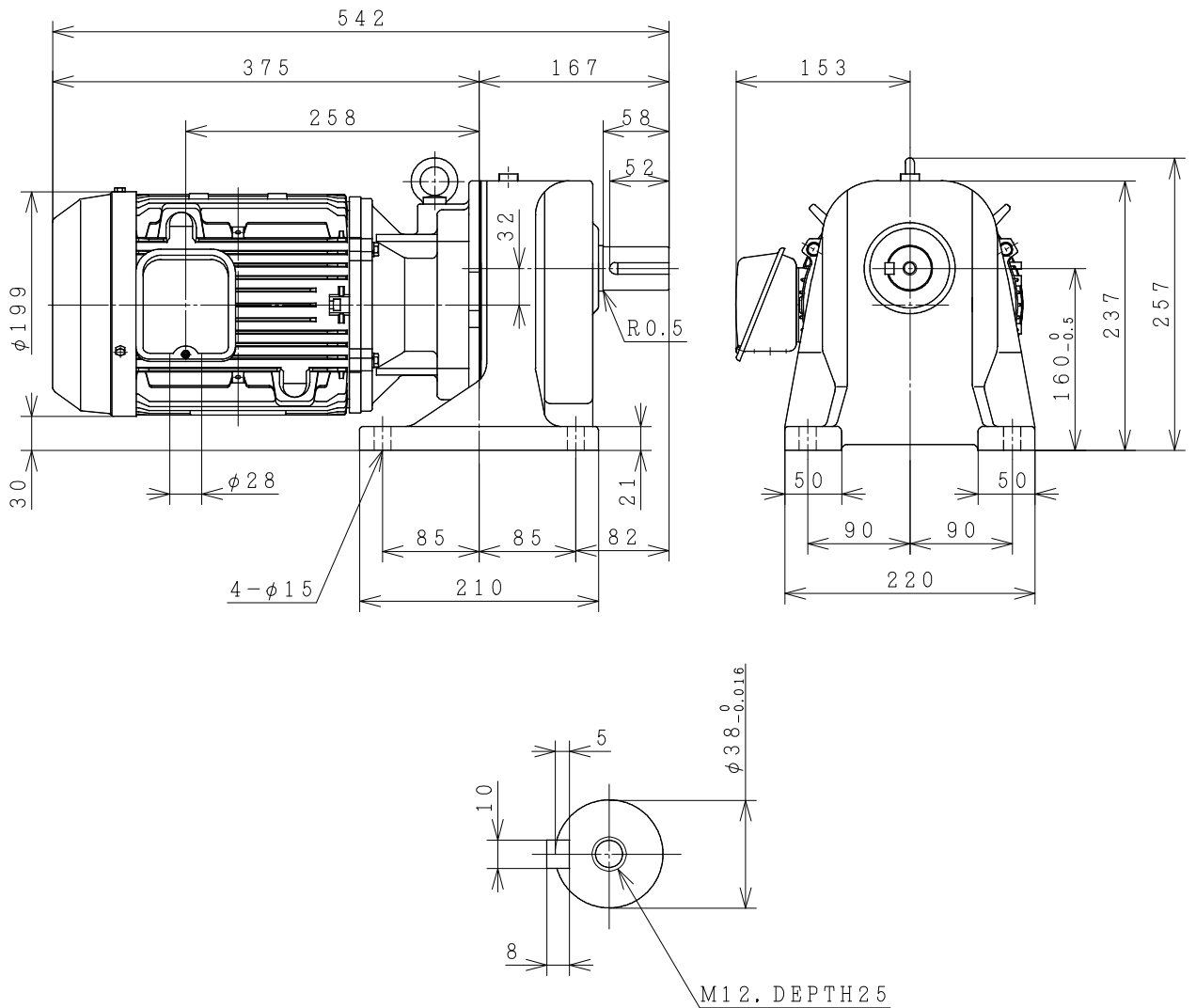

PROJECTION

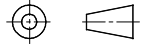

CUSTOMER			QTY.	ORDER No.	WORK No.	REV.
DWN. D. ITTIDECH	24-Jul-2015	S	DIMENSIONS		HITACHI <small>Hitachi Industrial Technology (Thailand), Ltd.</small> HITT WORKS DWG. No. 4HTD03136	
CHKD. M. KAMIZONO						
APPD. M. KAMIZONO						
FRAME SIZE (GH) 2.2kW 1/20, 1/15, 1/10, 1/5					SH.	