

LIFTER UNITS

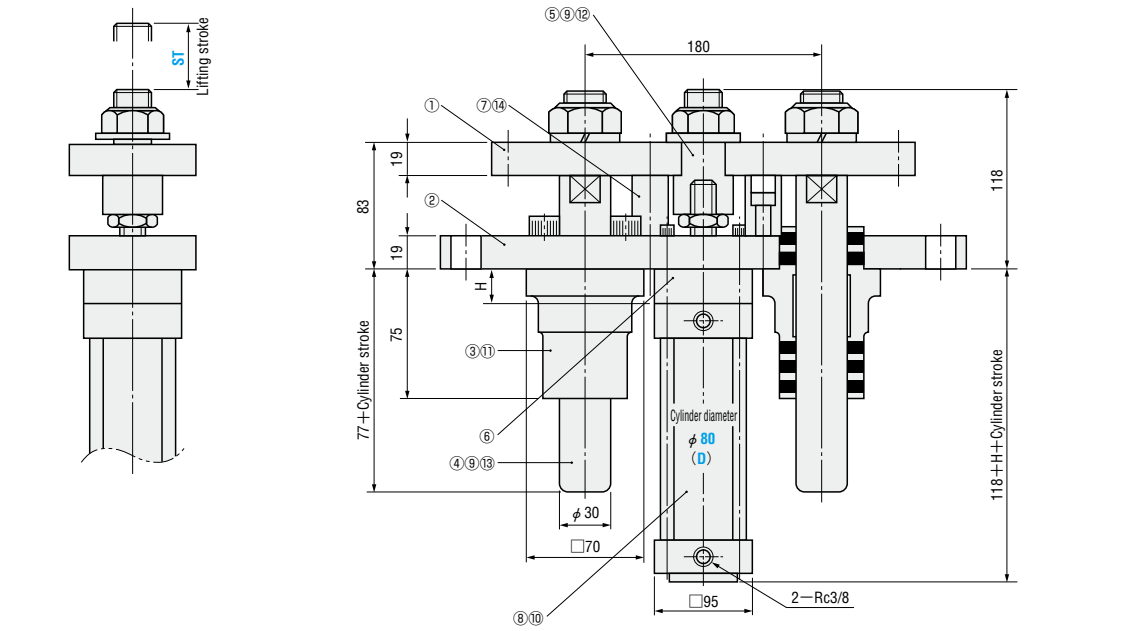
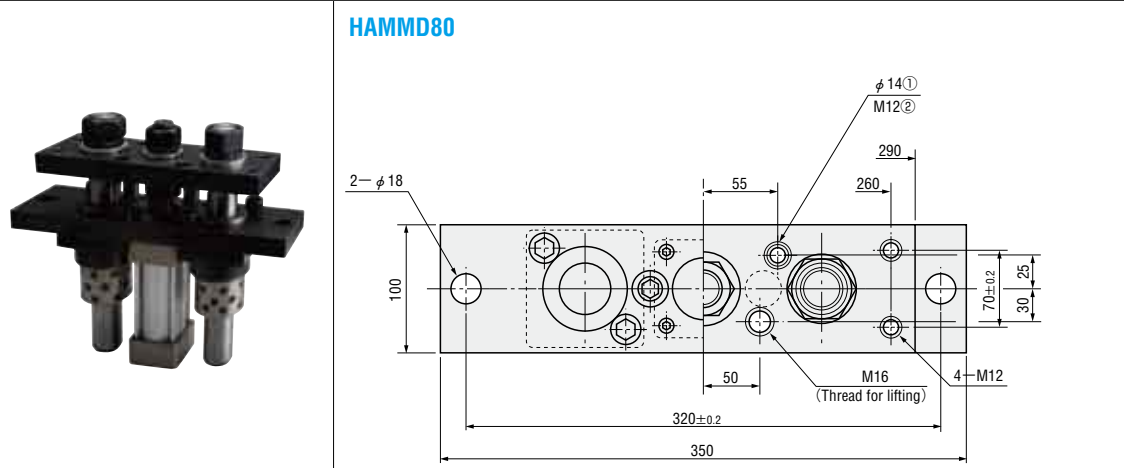

Components list

No.	Name	Qty.	Material & remarks	No.	Name	Qty.	Material & remarks
①	Lifting plate	1	Equivalent to SS400	⑨	Nut	3	M24
②	Mounting base plate	1	Equivalent to SS400	⑩	Hexagon socket head cap bolt	4	M10
③	Guide bushing	2	FC250 oil-free	⑪	Hexagon socket head cap bolt	4	M12 × 35
④	Guide bar	2	S45C HRC50 ~ 60	⑫	Flat washer	1	For M24
⑤	Link block	1	S45C	⑬	Spring washer	2	For M24
⑥	Padding block	1	Equivalent to SS400	⑭	Hexagon socket head cap bolt	2	M8 × 30
⑦	Cushion block	2	Urethane				
⑧	Cylinder	1	Made by AIRTAC				

Lifting stroke ST	10	20	30	40	50	60	70	80	90	100	110	120	130	140	150
Height of retainer H	40	30	20	10	—	40	30	20	10	—	40	30	20	10	—
Cylinder stroke	50					100					150				

Lifting stroke ST	160	170	180	190	200	210	220	230	240	250
Height of retainer H	40	30	20	10	—	40	30	20	10	—
Cylinder stroke	200					250				

Catalog No.	Cylinder dia. (D)	Lifting stroke ST 10mm increment
HAMMD	80	10~50
		60~100
		110~150
		160~200
		210~250

● Actual cylinder output
Air pressure: 500kPa
approx. 2450×0.7=1715N

Order Catalog No. **HAMMD** (D) **80** - ST **120**

Days to Ship **Quotation**

Price **Quotation**

Alterations Catalog No. **HAMMD** (D) **80** - ST **120** - (S) **S**

Alteration	Code	Spec.
Cylinder change	S	Change to SMC cylinder

■ Retainer (6) For LIFTER UNITS
HAMMG

Equivalent to SS400

Catalog No.	(D)	T
HAMMG	80	10
		20
		30
		40

Order Catalog No. **HAMMG** (D) **80** - T **20**

Days to Ship **Quotation**

Price **Quotation**

ex Example
See the illustration for the space for casting installation.

