

LIFTER UNITS

HAMMD40

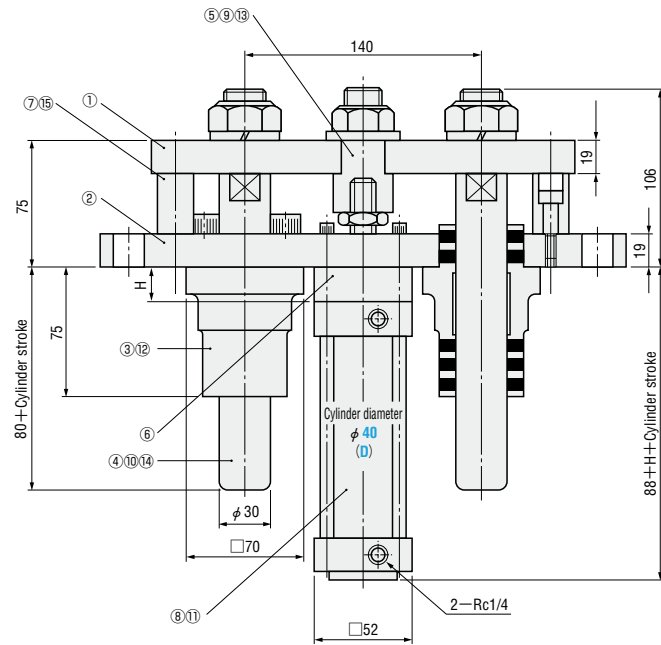
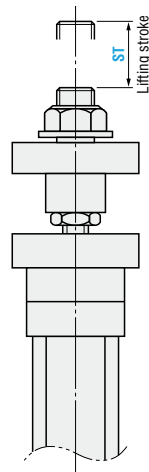
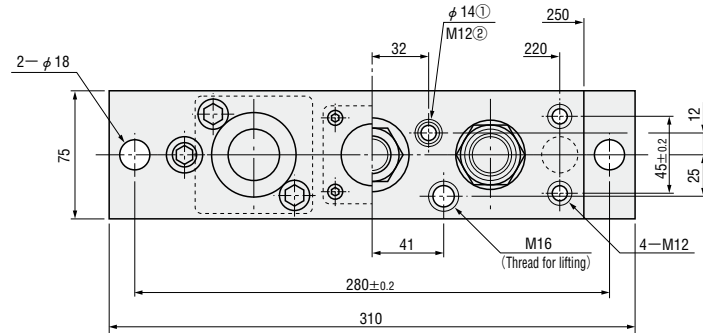

Components list

No.	Name	Qty.	Material & remarks	No.	Name	Qty.	Material & remarks
①	Lifting plate	1	Equivalent to SS400	⑨	Nut	1	M20
②	Mounting base plate	1	Equivalent to SS400	⑩	Nut	2	M24
③	Guide bushing	2	FC250 oil-free	⑪	Hexagon socket head cap bolt	4	M6
④	Guide bar	2	S45C HRC50 ~ 60	⑫	Hexagon socket head cap bolt	4	M12 × 35
⑤	Link block	1	Equivalent to SS400	⑬	Flat washer	1	For M20
⑥	Padding block	1	Equivalent to SS400	⑭	Spring washer	2	For M24
⑦	Cushion block	2	Urethane	⑮	Hexagon socket head cap bolt	2	M8 × 30
⑧	Cylinder	1	Made by AIRTAC				

Lifting stroke ST	10	20	30	40	50	60	70	80	90	100	110	120	130	140	150
Height of retainer H	40	30	20	10	—	40	30	20	10	—	40	30	20	10	—
Cylinder stroke	50					100					150				

Lifting stroke ST	160	170	180	190	200	210	220	230	240	250
Height of retainer H	40	30	20	10	—	40	30	20	10	—
Cylinder stroke	200					250				

Catalog No.	Cylinder dia. (D)	Lifting stroke ST 10mm increment
HAMMD	40	10~50
		60~100
		110~150
		160~200
		210~250

● Actual cylinder output
Air pressure: 500kPa
approx. 600×0.7=420N

Order **Catalog No.** **(D)** - **ST**
HAMMD 40 - 110

Days to Ship **Quotation**

Price **Quotation**

Alterations **Catalog No.** **(D)** - **ST** - **(S)**
HAMMD 40 - 110 - S

Alteration	Code	Spec.
Cylinder change	S	Change to SMC cylinder

Retainer (6) For LIFTER UNITS
HAMMG

Equivalent to SS400

Catalog No.	(D)	T
HAMMG	40	10
		20
		30
		40

Order **Catalog No.** **(D)** - **T**
HAMMG 40 - 30

Days to Ship **Quotation**

Price **Quotation**

ex Example

See the illustration for the space for casting installation.

