

LIFTER PIN SETS

— WITH PILOT PUNCH RELIEF HOLES —

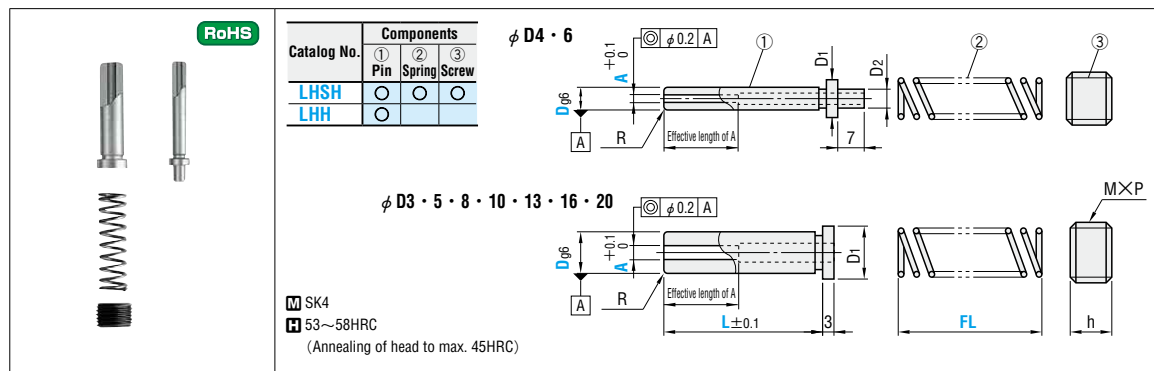

① LHH		③ MSW		Catalog No.			② Spring		Base unit price 1~19 pieces				
D ₆	D ₁	D ₂	R	M×P	h	Type	D	L	A	Type	FL	LHSH	LHH
3	4	—	2	5×0.8	5	LHSH (①②③) LHH (①)	3	20.0~30.0	0.8~1.4 (0.1mm increments)	WR WF WL WT WM WH	20 25 30 35 40 45 50 55 60 65 70 80 90 100	Quotation	
4	6	3	2	8×1.25	8		4	20.0~50.0	1.0~2.3 (0.1mm increments)				
5	6.4	—	3	10×1.5	10		5	20.0~50.0	1.4~3.0 (0.1mm increments)				
6	8	4.6	3	12×1.5	12		6	20.0~50.0	1.4~3.5 (0.1mm increments)				
8	10	—	4	16×1.5	16		8	20.0~50.0	1.4~5.3 (0.3mm increments)				
10	13	—	5	20×1.5	20		10	20.0~60.0	1.4~5.3 (0.3mm increments) 5.5 5.8 6.0 6.3 6.8 (Selection)				
13	16	—	6	22×1.5	22		13	20.0~60.0	1.8~9.3 (0.5mm increments)				
16	19	—	8	27×1.5	27		16	20.0~60.0*	2.0~11.5 (0.5mm increments)				
20	23	—	10				20	20.0~60.0*	2.0~15.5 (0.5mm increments)				

① Springs ② are unavailable in certain types and sizes. Check the "Combinations of guide lifter pin and spring" table on the page at right.
* If D=16·20 and L=20.0~30.0, the effective length of A may be equal to the L dimension.

Order **Catalog No.** — **L** — **A** — **② Type · FL**
LHSH 6 — 22.0 — 2.3 — WM40
LHH 8 — 35.0 — 3.5

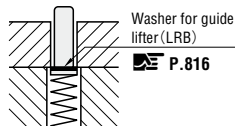
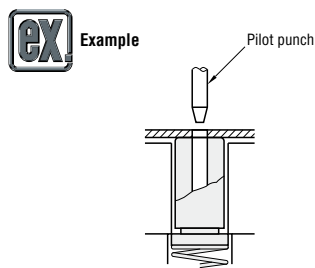

Days to Ship **Quotation**

Price **Quotation**

Alterations **Catalog No.** — **L** — **A (AC)** — **②** — (VSC · SN, etc.)
LHSH 13 — 50 — AC2.1 — WM60 — VSC

Alteration	Code	Spec.	1Code
	VSC	Lapping of pin end	Quotation
	AC	A dimension changed to 0.1mm increments A _{min} < AC < A _{max} . Can be used for D8~20.	
	SN	Elimination of spring guide (D ₂ =0) Can be used for D4~6.	
	WA	Change of provided screw plug to MSWA (through hole type) Can be used for LHSH only, D4~20 Detailed dimensions P.819	
	WZH	Change of provided screw plug to MSWZH (washer face type) Can be used for LHSH D6~20 only. MSW MSWZH D6~10 h=10 → h=12 D13~20 h=12 → h=15 Detailed dimensions P.819	

② Coil springs For detailed specifications, refer to P.1399~.

① Pin		② Spring						
Catalog No.	Type	WR	WF	WL	WT	WM	WH	
LHSH	3	N/mm 0.3 {kgf/mm} {0.03}	N/mm 0.5 {kgf/mm} {0.05}	N/mm 1.0 {kgf/mm} {0.1}	1.5{0.15}	2.0{0.2}	2.9{0.3}	
	4							
	5							
	6							
	8							
	10							
	13							
	16							
	20							

Combinations of guide lifter pins and springs (○ indicates an available set.)

FL	Type · D	LHSH3				LHSH4 · LHSH5				LHSH6				LHSH8											
		WR4	WF4	WL4	WT4	WM4	WH4	WR6	WF6	WL6	WT6	WM6	WH6	WR8	WF8	WL8	WT8	WM8	WH8	WR10	WF10	WL10	WT10	WM10	WH10
20-25-30		○	○	○	○	○	○	○	○	○	○	○	○	○	○	○	○	○	○	○	○	○	○	○	○
35		○	○	○	○	○	○	○	○	○	○	○	○	○	○	○	○	○	○	○	○	○	○	○	○
40		○	○	○	○	○	○	○	○	○	○	○	○	○	○	○	○	○	○	○	○	○	○	○	○
45		○	○	○	○	○	○	○	○	○	○	○	○	○	○	○	○	○	○	○	○	○	○	○	○
50		○	○	○	○	○	○	○	○	○	○	○	○	○	○	○	○	○	○	○	○	○	○	○	○
55		○	○	○	○	○	○	○	○	○	○	○	○	○	○	○	○	○	○	○	○	○	○	○	○
60		○	○	○	○	○	○	○	○	○	○	○	○	○	○	○	○	○	○	○	○	○	○	○	○
65		○	○	○	○	○	○	○	○	○	○	○	○	○	○	○	○	○	○	○	○	○	○	○	○
70		○	○	○	○	○	○	○	○	○	○	○	○	○	○	○	○	○	○	○	○	○	○	○	○
80		○	○	○	○	○	○	○	○	○	○	○	○	○	○	○	○	○	○	○	○	○	○	○	○

FL	Type · D	LHSH10				LHSH13				LHSH16				LHSH20											
		WR13	WF13	WL13	WT13	WM13	WH13	WR16	WF16	WL16	WT16	WM16	WH16	WR18	WF18	WL18	WT18	WM18	WH18	WR22	WF22	WL22	WT22	WM22	WH22
20~70/5mm increments		○	○	○	○	○	○	○	○	○	○	○	○	○	○	○	○	○	○	○	○	○	○	○	○
80		○	○	○	○	○	○	○	○	○	○	○	○	○	○	○	○	○	○	○	○	○	○	○	○
90		○	○	○	○	○	○	○	○	○	○	○	○	○	○	○	○	○	○	○	○	○	○	○	○
100		○	○	○	○	○	○	○	○	○	○	○	○	○	○	○	○	○	○	○	○	○	○	○	○

* : Maximum allowable deflection F_{max} is smaller than the above spring constant. For details P.1399~.

Lifter pins — Precision type with pilot punch relief hole —

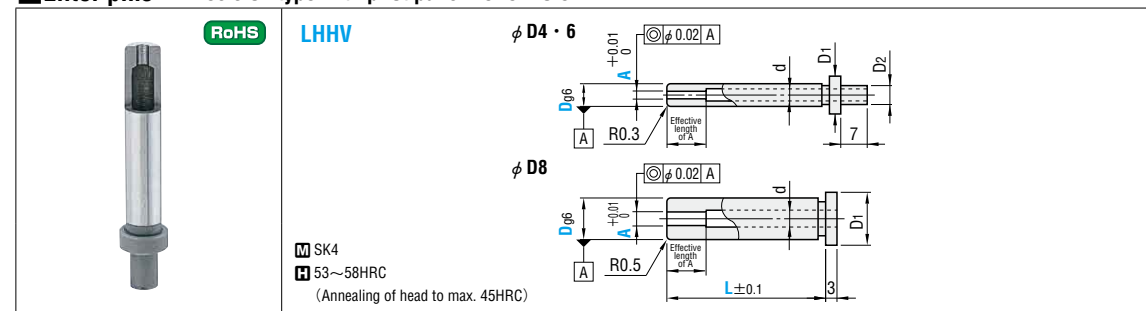

D ₆	D ₁	D ₂	Effective length of A	d	Catalog No.		L	A	Base unit price 1~19 pieces
					Type	D			
4	6	3	2	2.2	LHHV	4	20 22 25 30	1.00~1.60	Quotation
6	8	4.6	3	3.4		6	25 30 33 35	1.00~3.00	
8	10	—	4	4.4		8	30 33 35 40	1.00~4.00	

Order **Catalog No.** — **L** — **A**
LHHV 6 — 30 — 2.50

Alterations **Catalog No.** — **L** — **A** — (VSC · SN)
LHHV 6 — 30 — 2.50 — VSC

Days to Ship **Quotation**

Price **Quotation**

Alteration	Code	Spec.	1Code
	VSC	Lapping of pin end	Quotation
	SN	Elimination of spring guide (D ₂ =0) Can be used for D4~6.	