

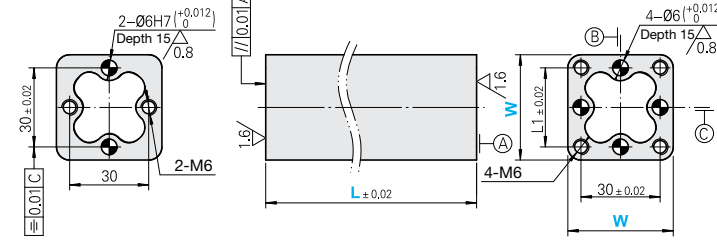

XCA40

M Material 6063A-T5
S Surface Treatment Blasting

* Tolerance is only for Dowel hole

XCA60
XCA80

M Material 6063A-T5
S Surface Treatment Blasting

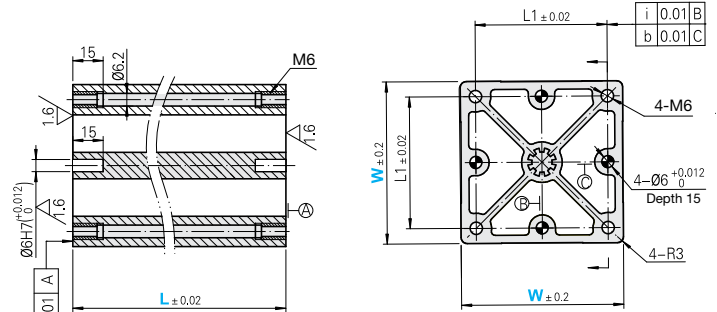
* Tolerance is only for Dowel hole

Catalog No.		Length (L)	L1
Type	Width (W)	25 mm Increment	
XCA	40	30 55 80 ~ 205	30
	60	30 55 80 ~ 305	48
	80	30 55 80 ~ 405	65

Order -
 XCA 40 - 80
 XCA 80 - 205

Delivery **Quotation**

XCDZA 40 (Attach with XCA40)

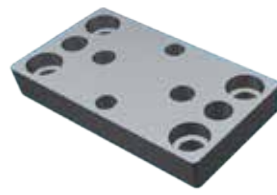
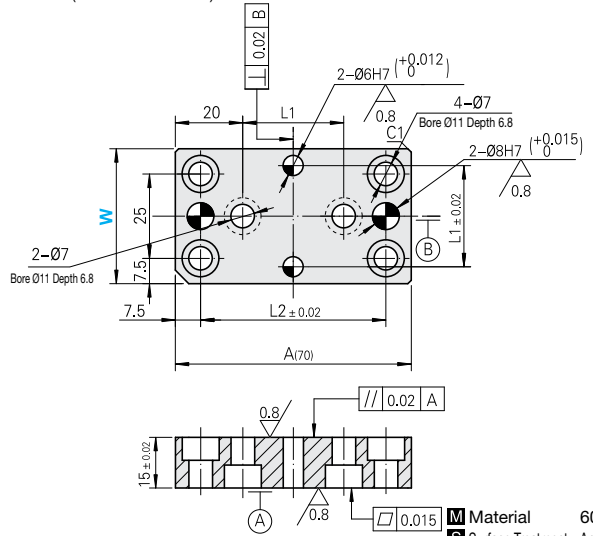
M Material 6061-T6
S Surface Treatment Anodizing coating

* Tolerance is only for Dowel hole

XCDZA 60 (Attach with XCA60)
XCDZA 80 (Attach with XCA80)

M Material 6061-T6
S Surface Treatment Anodizing coating

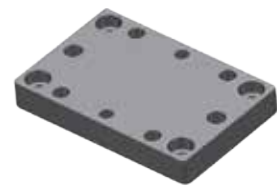
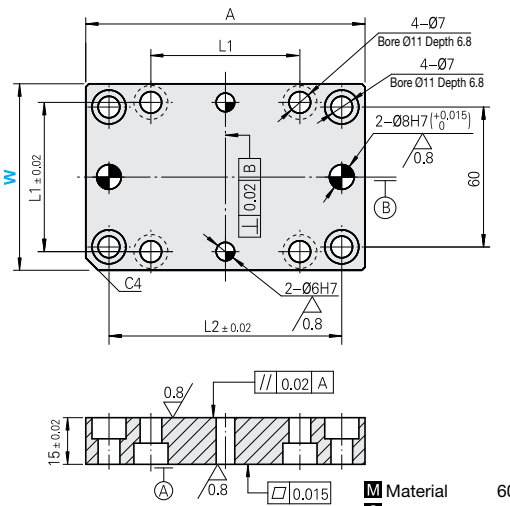
* Tolerance is only for Dowel hole

Catalog No.		L1	L2	A
Type	Width (W)			
XCDZA	40	30	55	70
	60	48	75	90
	80	65	100	120

Order
 XCDZA 40

Delivery **Quotation**