

W SHAPE STEEL / ALUMINUM HORIZONTAL FLIP COMPONENTS -SMALL TYPE-

W Shape Steel / Aluminum Horizontal Flip Components Push knob type

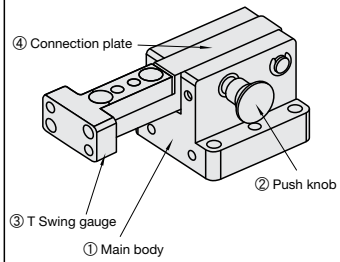

Code	Material	Left / Right	Surface Treatment
WSCWLC	S45C	L	Nickel coating
WSCWRC		R	
WAWLC	6063	L	Anodizing coating
WAWRC		R	

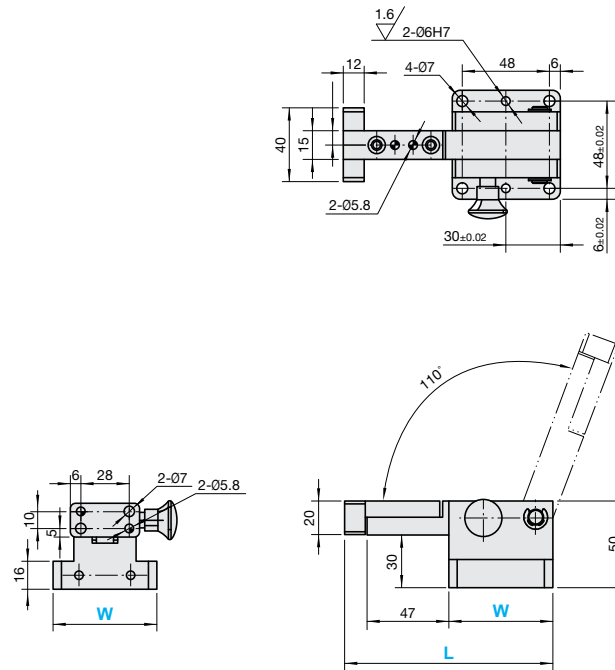

The above drawings are from Left side view and symmetric from Right side view

W Shape Steel / Aluminum Horizontal Flip Components Lever knob type

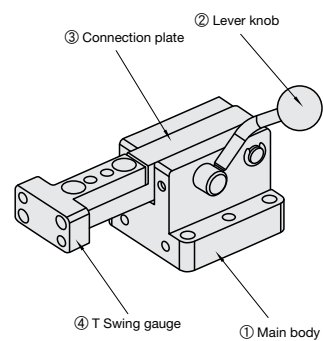

Code	Material	Left / Right	Surface Treatment
WSCWLY	S45C	L	Nickel coating
WSCWRY		R	
WAWLY	6063	L	Anodizing coating
WAWRY		R	

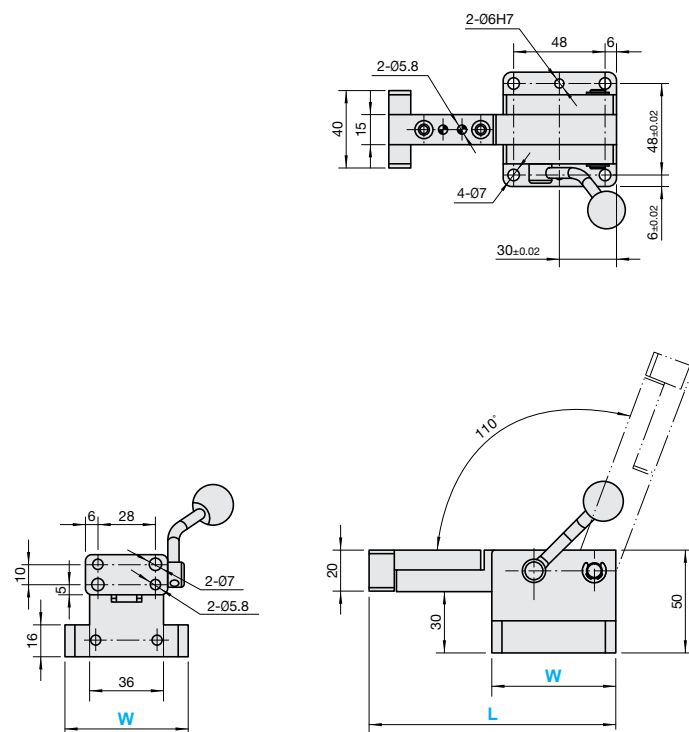

The above drawings are from Left side view and symmetric from Right side view

Material	Left / Right L/R	Catalog No.			Length (L)	Surface Treatment
		Type	Locking type	Width (W)		
Steel	L	WSCWL	C Y	60	120	Nickel coating
	R	WSCWR				
Aluminum	L	WAWL	C Y	60	120	Anodizing coating
	R	WAWR				

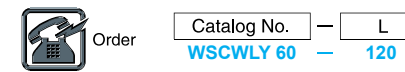

	Alterations	Code	Spec.
Change length		LC	Possible alteration length 120 < L < 270 (1mm Increment)
Swing gauge no hole		NBB	T swing gauge no hole (No heat treatment)

■ Base Support for Steel T Shape Flip Component



I Shape Support GZSC60 P.33

■ Base Support for Aluminum T Shape Flip Component



Base Support XCDZA60 P.36



Aluminum Frame Support XCA60 P.35