

# W SHAPE STEEL / ALUMINUM VERTICAL FLIP COMPONENTS -LARGE TYPE-

W Shape Steel / Aluminum  
Vertical Flip Component  
Push knob type

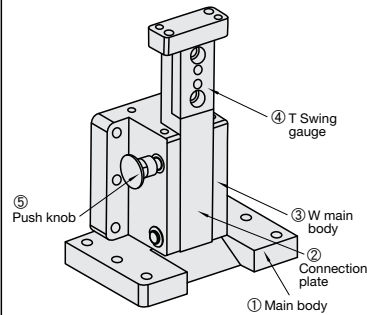

Code	Material	Left / Right	Surface Treatment
WSCLLC	S45C	L	Nickel coating
WSCLRC		R	
WALLC	6063	L	Anodizing coating
WALRC		R	

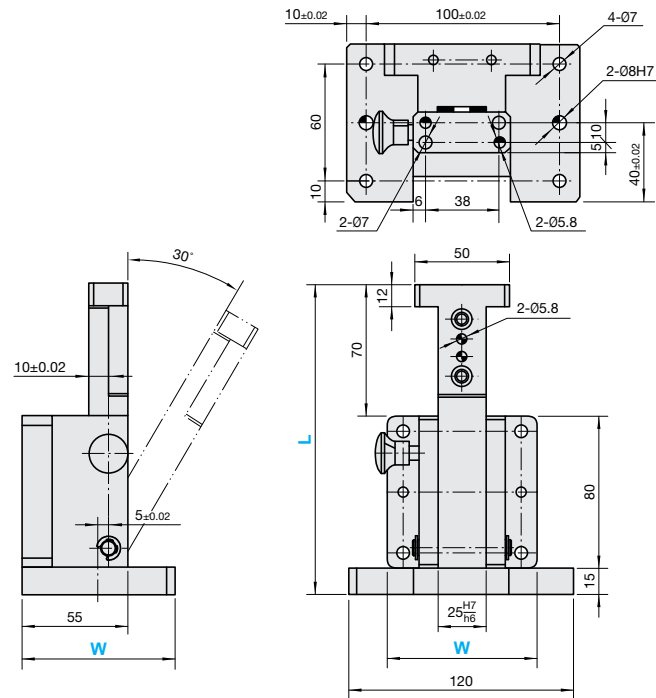

The above drawings are from Left side view and symmetric from Right side view

W Shape Steel / Aluminum  
Vertical Flip Component  
Lever knob type

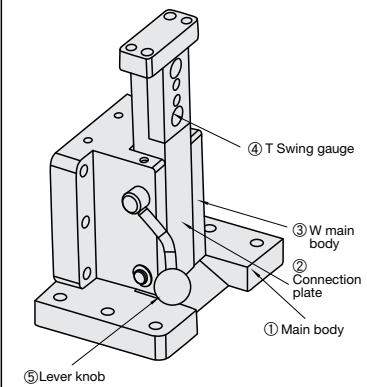

Code	Material	Left / Right	Surface Treatment
WSCLLY	S45C	L	Nickel coating
WSCLRY		R	
WALLY	6063	L	Anodizing coating
WALRY		R	

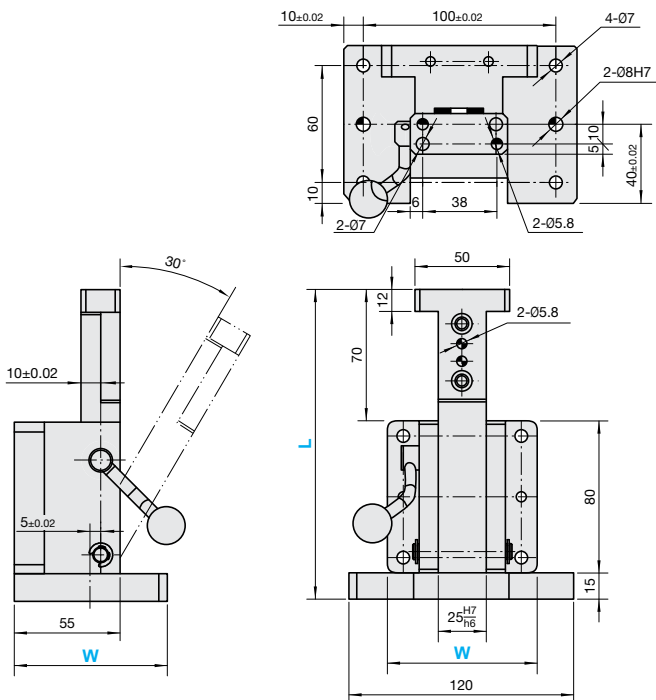

The above drawings are from Left side view and symmetric from Right side view

Material	Left / Right L/R	Catalog No.			Length (L)	Surface Treatment
		Type	Locking type	Width (W)		
Steel	L	WSCLL	C Y	80	165	Nickel coating
	R	WSCLR				
Aluminum	L	WALL	C Y	80	165	Anodizing coating
	R	WALR				

Order     
 WSCLLY 80 - 165

Delivery **Quotation**

Alterations

	Alterations	Code	Spec.
Change length		LC	Possible alteration length 165 < L < 295 (1mm Increment)
Swing gauge no hole		NBB	T swing gauge no hole (No heat treatment)