

# U SHAPE STEEL / ALUMINUM HORIZONTAL FLIP COMPONENTS -SMALL TYPE-

## Steel U Shape Horizontal Flip Component

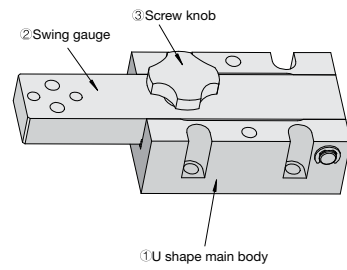

No.	Name	Material	Surface treatment
①	U shape main body	S45C	Nickel coating
②	Swing gauge	S45C	Nickel coating
③	Screw knob	PP	—

## USCWM

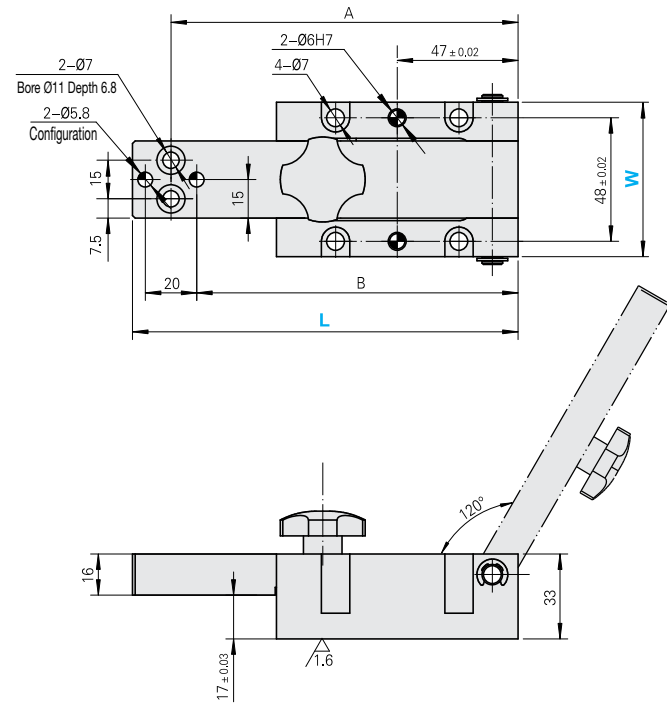

## Aluminum U Shape Horizontal Flip Component

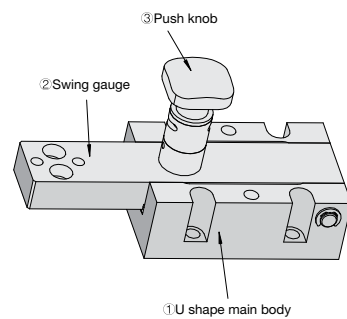

No.	Name	Material	Surface treatment
①	U shape main body	6063	Anodizing coating
②	Swing gauge	6061	Anodizing coating
③	Push knob	PP	—

## UAWK

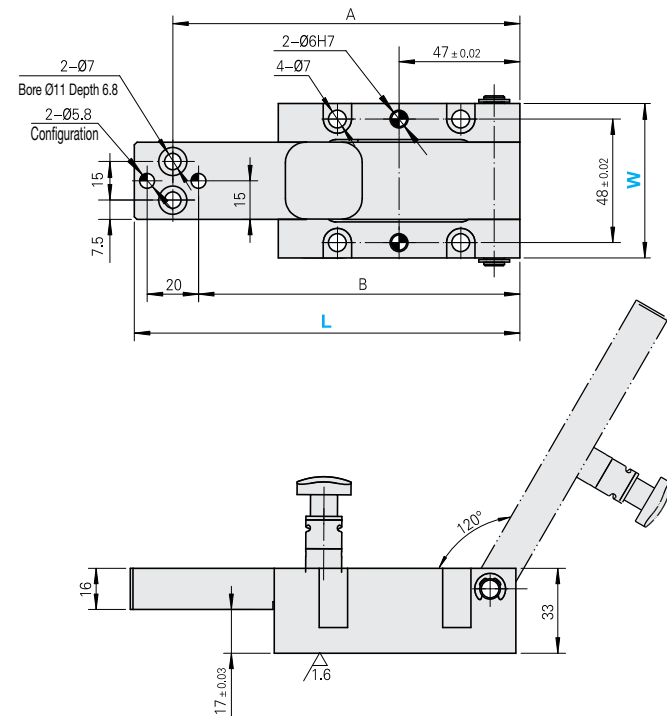

Vertical / Horizontal	Main material	Locking type	Catalog No.		Length (L)	A	B
			Type	Width (W)			
Vertical	Steel	Screw type	USCWM	60	150	135	125
					180	165	155
	Aluminum	Push type	UAWK		150	135	125
					180	165	155

Order  -

Delivery **Quotation**

Alterations

	Alterations	Code	Spec.
No hole for swing gauge		NBB	No hole for swing gauge (No heat treatment)
Change length for swing gauge		LC	Possible alteration length 150 < L < 180 (1mm Increment)

### ■ Base Support for Steel U Shape Flip Component



I Shape Support GZSC60 P.33

### ■ Base Support for Aluminum U Shape Flip Component



Base Support XCDZA60 P.36



Aluminum Frame Support XCA60 P.35