

U SHAPE STEEL / ALUMINUM VERTICAL FLIP COMPONENTS -LARGE TYPE-

Steel U Shape Vertical Flip Component

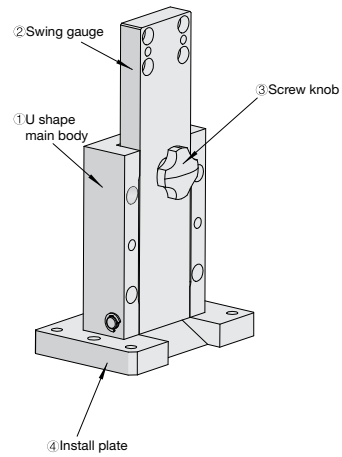

No.	Name	Material	Surface treatment
①	U shape main body	S45C	Nickel coating
②	Swing gauge	S45C	Nickel coating
③	Screw knob	PP	—
④	Install plate	S45C	Nickel coating

USCLM

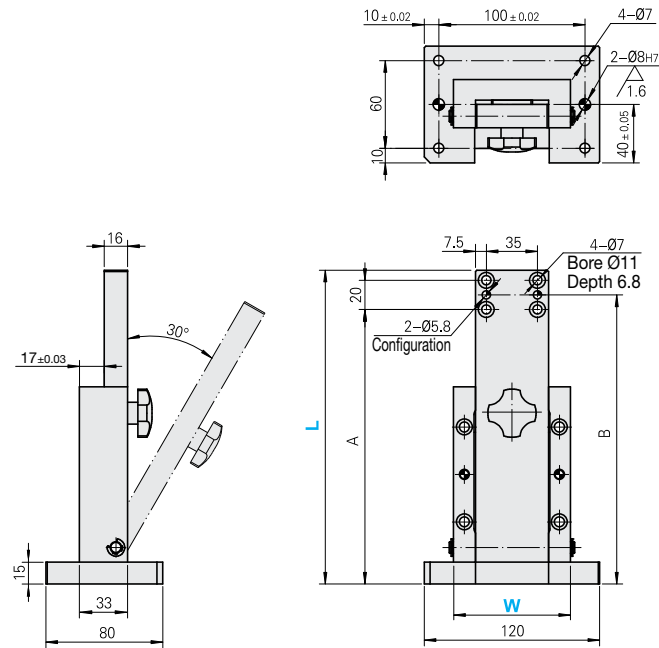

Aluminum U Shape Vertical Flip Component

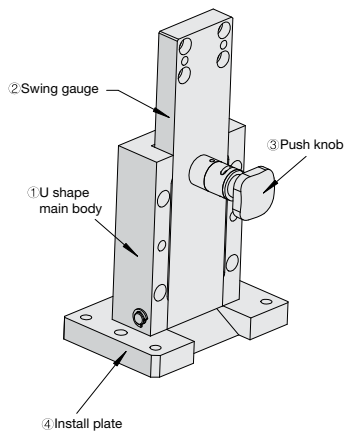

No.	Name	Material	Surface treatment
①	U shape main body	6063	Anodizing coating
②	Swing gauge	6061	Anodizing coating
③	Push knob	PP	—
④	Install plate	6061	Anodizing coating

UALK

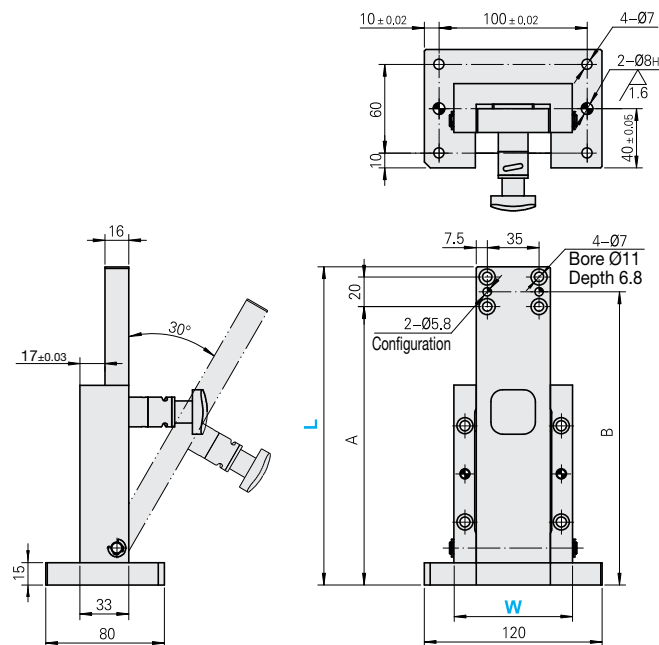

Vertical / Horizontal	Main material	Locking type	Catalog No.		Height (L)	A	B
			Type	Width (W)			
Vertical	Steel	Screw type	USCLM	80	215	188	198
					255	228	238
	Aluminum	Push type	UALK	80	215	188	198
					255	228	238

Order —
 USCLM 80 — 215

Delivery **Quotation**

Alterations

	Alterations	Code	Spec.
No hole for swing gauge		NBB	No hole for swing gauge (No heat treatment)
Change length for swing gauge		LC	Possible alteration length 215 < L < 255 (1mm Increment)