



# II型スタンド -アルミ鋳造-

## II SHAPE SUPPORT

-CAST ALUMINUM-

STAND COMPONENTS

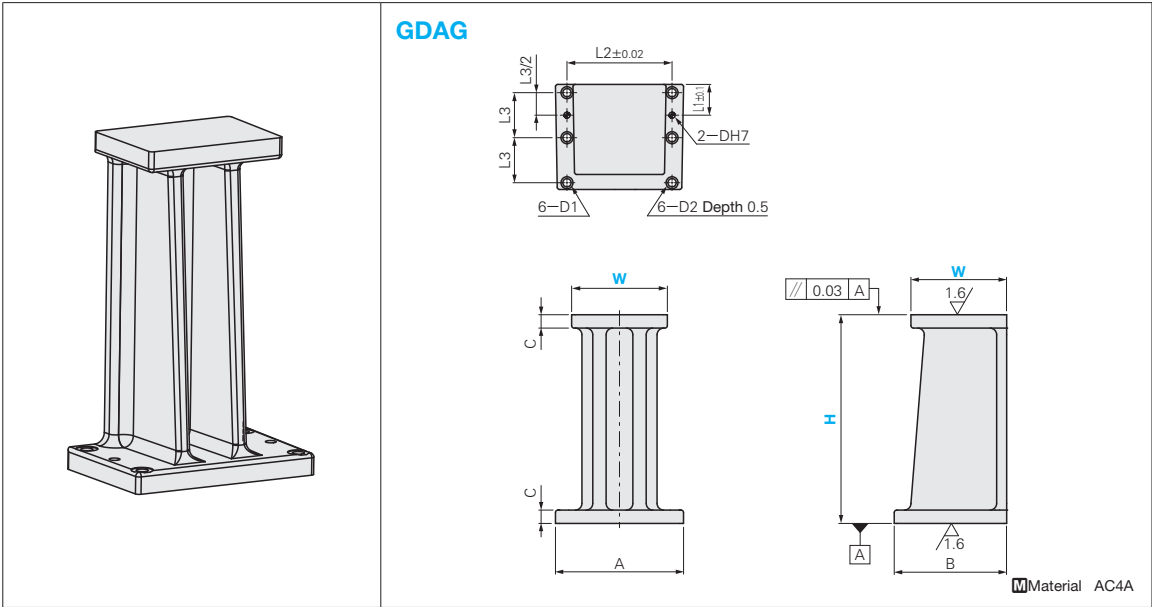

Catalog No. Type		W	H	L1	L2	L3	D	D1	D2	A	B	C
<b>GDAG</b>	120	75	120	40	146	60	8	11	19	166	140	18
		100										
		125										
		150										
		200										
		250										
		300										
		350										
		400										
		450										
500												



Order Catalog No. **GDAG 120** - H **250**



Alterations Catalog No. **GDAG 120** - H **250** - (B) **B**



Delivery **Quotation**

Alterations	Code	Spec.
Surface coated with blue paint	<b>B</b>	Non-operating surface of support coated with blue paint.



**Example** The top side can be used for mounting various components or serves as the supporting structure. Various usage needs are satisfied by selecting different sizes and heights of the mounting surface.

- \* Applicable to WSCWM, USWML, USCLM and UALK series components;
- \* Also applicable to other standard/non-standard components with the same mounting dimensions.

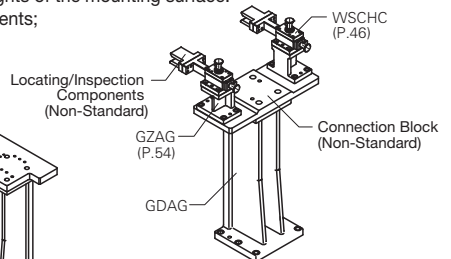
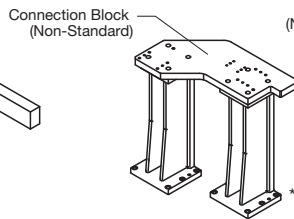
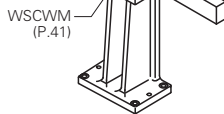
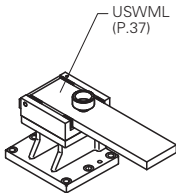

\* Used as bottom support members and joints between other standard/non-standard components, meeting the locating/inspection needs under various circumstances.