

SHOT COUNTERS FOR MOLD

 Stock Items in Thailand

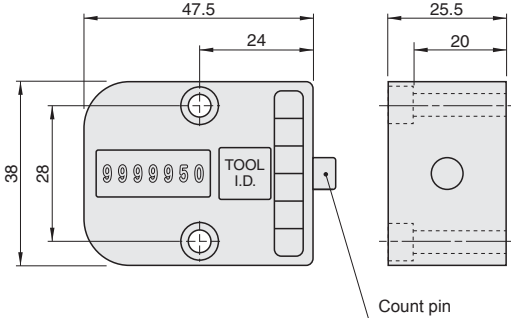

C-CVPL



Product design is subject to change without prior notice.
 Heat-resistance capacity: 120°C
 Hexagon socket bolts (M4-25, 2 pcs.) are recommended for installation. Material Nylon (containing glass fiber)



Order

Part Number

C-CVPL



Delivery



1

Day



Price

Contact Information for Inquiry

WOS: <http://th.misumi-ec.com/>

Features

- The counter adopts a mechanical structure which reduces possibilities of malfunctions, thus ensuring correct counting of mold opening times.
- Mold No. can be inscribed on the mold nameplate included in the accessories.

Precautions

- In order to guarantee counting reliability, the digits are made not resettable.
- Because of factors such as mold testing, etc., the factory setting value indicated by the 7 digits is not "0". (Approx. 9999950)

Installation Dimensions (Reference Values) and Method

C-CVPL

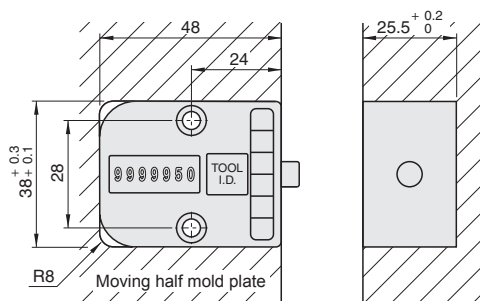

- The installation dimensions indicated left are reference values.
- The stroke amount of the count pin required should be larger than 3.2mm. If the stroke amount is less than 3.2mm, counting will be impossible. However, if it is greater than 4.0mm, the counter may be damaged, so please be careful in operation.