

ANGULAR CAMS

—ANGLE SELECTION TYPE / ANGLE DESIGNATION TYPE—

ⓘ Non JIS material definition is listed on P.1351 - 1352

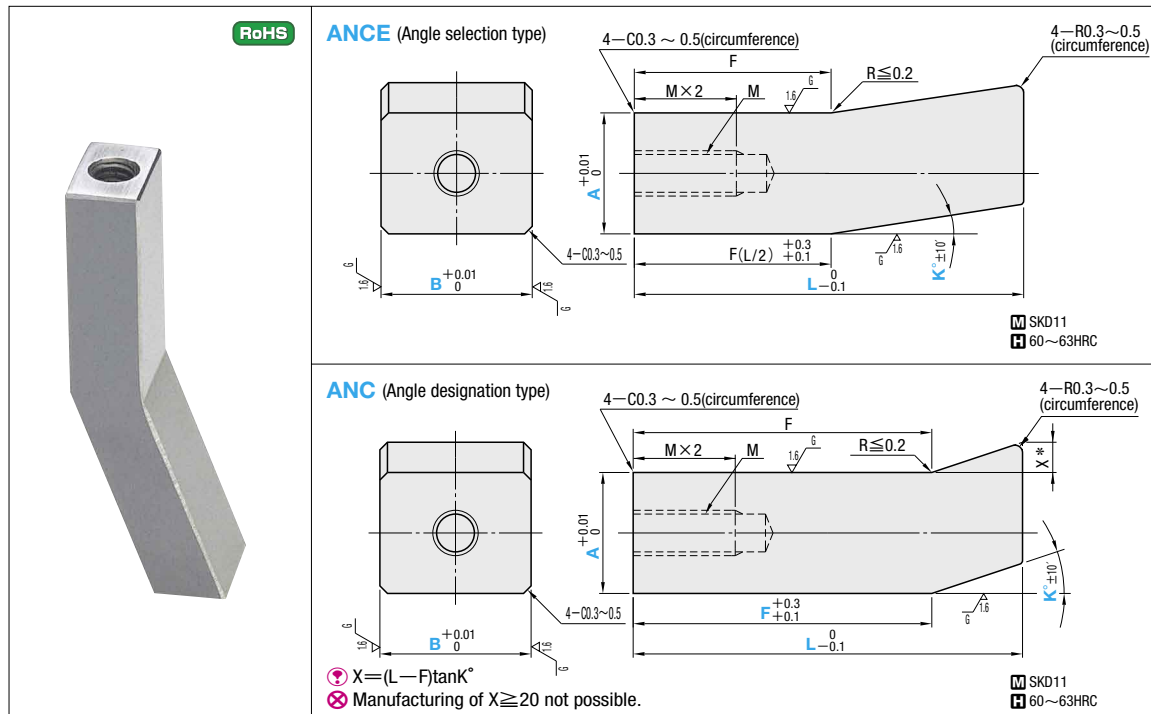

Angle Selection Type

M×Pitch	Part Number		B		L				K°		
	Type	A									
M6×1.0	ANCE	10	10	15	30	40	60	80	15	18	20
M8×1.25		15	10	15	30	40	60	80			

Angle Designation Type

M×Pitch	Part Number		B				0.1mm increments		K°	
	Type	A					L	F		
M6×1.0	ANC	10	10	15	20	25	30	20.0~80.0	15.0 ≤ F ≤ L - 10	10~25
M8×1.25		15	10					20.0~100.0		
			15	20	25	30	20.0~120.0			
			20	20	25	30	20.0~150.0			
			25	20	25	30	20.0~120.0			
		25	20	25	30	20.0~150.0				

Order

Part Number	B	L	F	K
ANCE10	B10	L30		K15
ANC10	B20	L50.0	F30.0	K20

Days to Ship **Quotation**

Precision Standard

Reference item	Outline	Allowable range
Squareness of A · B dimension		Squareness of B plane against the vertical direction of A plane. a ≤ 0.02
Parallelism of A · B dimension		Parallelism between top and bottom planes in F direction referring to A or B plane. b ≤ 0.02

Finishing of corners



Price **Quotation**

Alterations

Part Number	B	L	F	K	(GC · MC · LC · FC)
ANCE10	B10	L40		K20	LC38.6 - FC19.3
ANC15	B25	L80.0	F50.0	K20	GC25.0

Quotation

Alterations	Code	Spec.	1Code																								
	LC FC	<p>Available for ANCE only.</p> <p>Cuts L and F dimension.</p> <p>LC and FC=0.1mm increments</p> <p>With FC, the overall length becomes shorter by (F-FC). However, the tap length remains unchanged. When LC is combined, the overall length becomes the same as LC.</p> <p>When LC and FC are combined: LC ≤ L - (F - FC) LC - FC ≥ 10</p> <table border="1"> <caption>Designation range of LC and FC</caption> <thead> <tr> <th>L</th> <th>F</th> <th>LC</th> <th>FC</th> </tr> </thead> <tbody> <tr> <td>30</td> <td>15</td> <td>25.0~29.9</td> <td>—</td> </tr> <tr> <td>40</td> <td>20</td> <td>30.0~39.9</td> <td>15.0~19.9</td> </tr> <tr> <td>60</td> <td>30</td> <td>40.0~59.9</td> <td>20.0~29.9</td> </tr> <tr> <td>80</td> <td>40</td> <td>50.0~79.9</td> <td>30.0~39.9</td> </tr> <tr> <td>100</td> <td>50</td> <td>60.0~99.9</td> <td>40.0~49.9</td> </tr> </tbody> </table> <p>Designation method</p> <ol style="list-style-type: none"> When LC is used : ANCE10—B10—L40—K20—LC38.6 When FC is used : ANCE10—B10—L40—K20—FC19.3 When LC and FC are combined : ANCE10—B10—L40—LC38.6—FC19.3 	L	F	LC	FC	30	15	25.0~29.9	—	40	20	30.0~39.9	15.0~19.9	60	30	40.0~59.9	20.0~29.9	80	40	50.0~79.9	30.0~39.9	100	50	60.0~99.9	40.0~49.9	Quotation
L	F	LC	FC																								
30	15	25.0~29.9	—																								
40	20	30.0~39.9	15.0~19.9																								
60	30	40.0~59.9	20.0~29.9																								
80	40	50.0~79.9	30.0~39.9																								
100	50	60.0~99.9	40.0~49.9																								

Alteration	Code	Spec.	1Code	Alteration	Code	Spec.	1Code
	GC	<p>Available for ANCE · ANC</p> <p>Adds a cut on the back.</p> <p>GC=0.1mm increments</p> <p>A ≤ GC ≤ ((L - F)tanK) + A</p>	Quotation		MC	<p>Available for ANCE · ANC</p> <p>Changes the tap diameter from M8 to M6 for A dimensions of 15/20/25.</p>	Quotation

Features

- Makes machining mold bases easier.
- Can also be used as a locking block when injection pressure is low.

Example

• Example of ANCE/ANC use

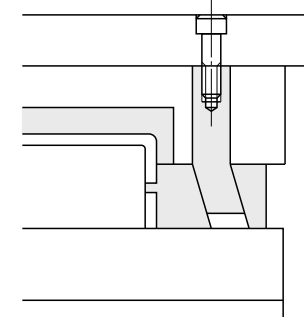

• Example of GC Alteration use

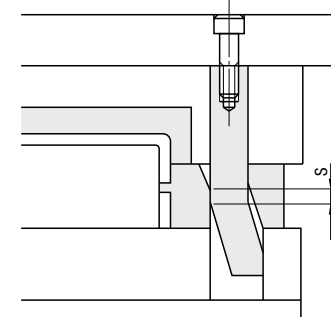

• Makes timing adjustment (S) for slide opening.