

Thin Brackets

For 6 Series (Slot Width 8mm) Aluminum Extrusions

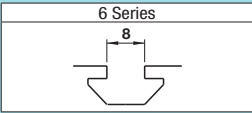

■ **Features:** Thin Extruded Brackets with space saving design.

■ **Thin Brackets**



Type	Material	Surface Treatment
HBLSS6	A6N01SS-T5	Anodize
HBLSSB6		Black Anodize
HBLSD6-50		Anodize

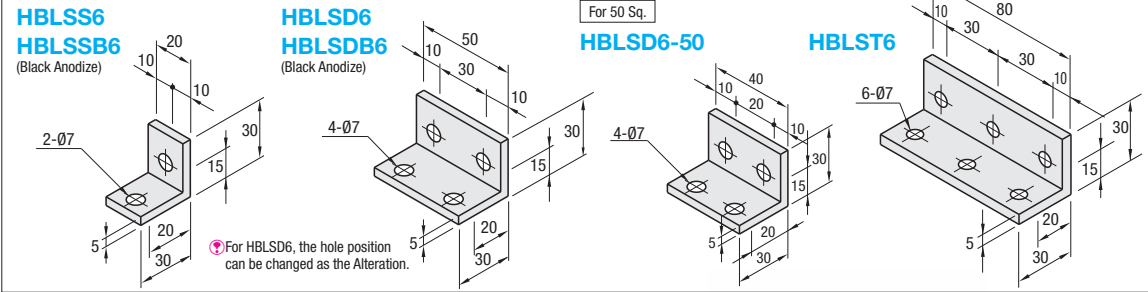

Part Number Type	Mass (g)	Applicable Screw, T Nut				Allowable Load (N)	Unit Price (1-99 pcs)	Volume Discount Rate 100-200
		Screw	Qty.	T Nut	Qty.			
HBLSS6	14	CBM6-12	2	HNTT6-6	2	980		
HBLSSB6* (Black Anodize)								
HBLSD6	35	CBM6-12	4	HNTT6-6	4	1568		
HBLSD6B* (Black Anodize)								
HBLSD6-50	28		4		4	1568		
HBLST6	56		6		6	2352		

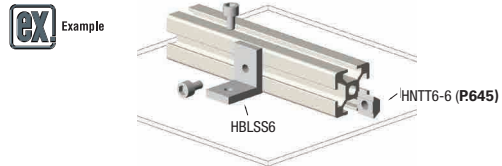

Ordering Example
Part Number: HBLSS6

Alterations
Part Number: (P, SET, SST, SEU, SSU, SEP, SSP)
HBLSD6 - P
HBLSP6 - SET
HBLSD6 - P-SET

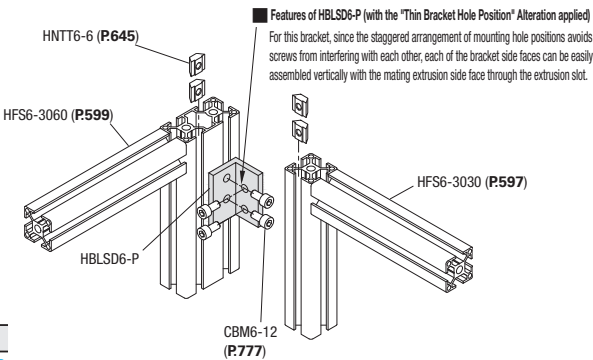

Alterations	Code	Spec.	Applicable Bracket	JPY/1Code
Applicable Screws and Nuts Set	SET	Applicable screws and nuts for fixing the brackets on extrusions come in a set. (Adds to the bracket price.) (Ex.) When HBLSS6 is specified: Code Part Number Qty. Part Number Qty. SET CBM6-12 HNTT6-6 SST SCB6-12 HNTR6-6 SEU CBM6-12 HNTR6-6 SSU SCB6-12 HNTR6-6 SEP CBM6-12 HNTR6-6 SSP SCB6-12 HNTR6-6 *When specifying other than HBLSS6, check for the applicable screws and nuts.	HBLSS6	SET SST SEU SSU SEP SSP
	SST		HBLSSB6	- - - -
	SEU		HBLSD6	- - - -
	SSU		HBLSD6B6	- - - -
	SEP		HBLST6	- - - -
	SSP		HBLSD6-50	- - - -
			HBLSP6	- - - -
			HBLBL6	- - - -

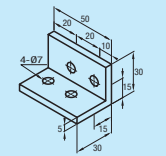
Alteration	Code	Spec.	Applicable Bracket
Thin Bracket Hole Position	P	Changes the screw-mounting hole positions for Thin Brackets, HBLSD6. 	HBLSD6

⚠ Screws for black anodized brackets are made of HCBMTB (Trivalent Chromate Black) on P.777.
⚠ Included Screw is not RoHS compliant when -SET, -SEU or -SEP is specified for any bracket other than black anodized ones.

■ **Features:** Thin Brackets with tabs to fit in slots of extrusions. Since the tabs serve as the rotation stoppers for brackets when tightening, work efficiency is improved.

■ **Thin Stainless Steel Tabbed Brackets**

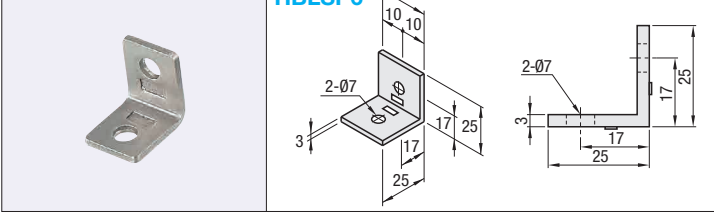

Ordering Example
Part Number: HBLSP6



Part Number Type	Mass (g)	Applicable Screw, T Nut				Allowable Load (N)	Unit Price (1-99 pcs)	Volume Discount Rate 100-200
		Screw	Qty.	T Nut	Qty.			
HBLSP6	33	CBM6-12	2	HNTT6-6	2	980		

Alterations
* Supplies a set of applicable screws and nuts for fixing the bracket to an extrusion. See the above Alterations Table.