

Bushings for Locating Pins - High Hardness Stainless Steel Straight

For products uncovered by e-Catalog Standard, see P.131.

Features: This product is much lower than, and can be delivered more quickly than the existing products.



RoHS 10

Type			Material	Hardness
Dp6	Dm6	Dh7		
JBK	JBKM	JBKS	High Hardness Stainless Steel	35HRC~

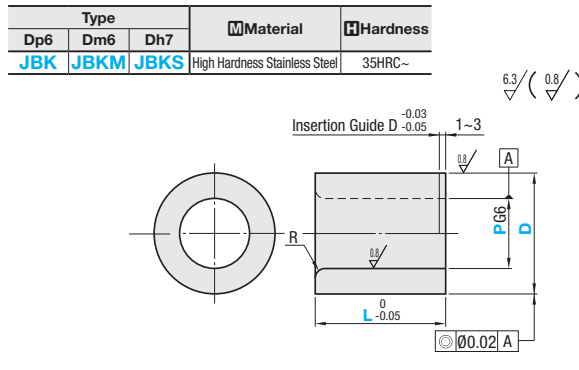

D	p6	m6	h7
5	+0.020 +0.012	+0.012 +0.004	0 -0.012
7	+0.024 +0.015	+0.015 +0.006	0 -0.015
12	+0.029 +0.018	+0.018 +0.007	0 -0.018

Straight

Part Number		P 0.1mm Increment	L 0.1mm Increment	R	Unit Price 1~19 pc(s).	Volume Discount Rate		
Type	D					20~49 pcs.	50~100 pcs.	101~300 pcs.
JBK (p6) JBKM (m6) JBKS (h7)	5	2.0~3.0	5.0~10.0	0.5				
	7	2.0~5.0						
	8	3.0~6.0	5.0~15.0					
	10	4.0~8.0						
	12	6.0~10.0	5.0~30.0					
	14	6.0~10.0						
15	8.0~12.5	5.0~40.0						

Ordering Example

Part Number	- P - L		
Type	D	P	L
JBKM	8	5.9	12.0
JBKS	10	8.0	20.0

Alterations

Part Number	- P - L - (FC, RS, RN, CRN)		
Type	D	P	L
JBKM	7	3.2	10.0 - FC
JBKS	12	8.0	25.0 - CRN

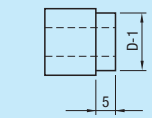
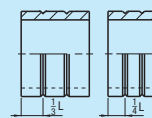
Alterations	Code	Spec.
Groove (for Adhesive Reservoir) 	FC	Adds an adhesive reservoir groove. D ≥ P+3: Applicable only when a wall of 1.5mm or thicker is remaining. Applicable only when L ≥ 10.
Adhesive Groove Machining When L ≤ 13.0 When L > 13.0 	RS	Adds an adhesive groove. Number of O.D. Grooves When L ≤ 13.0 → 2 lines When L ≤ 13.0 → 3 lines [Ordering Code] RS When D ≤ 13, D - P ≥ 3. When D ≥ 14, D - P ≥ 4. Not applicable when L < 9.0.

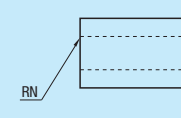
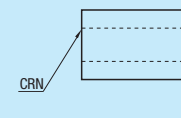
Alterations	Code	Spec.
Radius R C Chamfered 	RN	Adds C Chamfering (0.5 or less) to R.
Radius R Square Corner 	CRN	Replaces R with square corner. Edge may be burred.