

Extruded Brackets - For 3 or More Slots

For 8 Series (Slot Width 10mm) Aluminum Extrusions

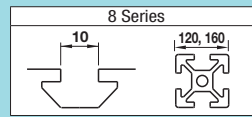

■ **Features:** Brackets to connect Extrusions with 3 slots (HFS8-40120 etc.) with one bracket.

Ultra Thick Brackets

NBLUT8
HBLUT8

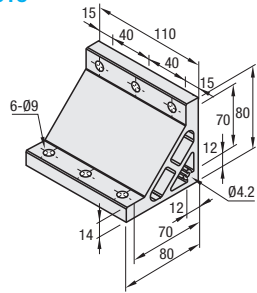

Type	Material	Surface Treatment
NBLUT8	A6063S-T5	Anodize
HBLUT8	AGN01SS-T5	Anodize

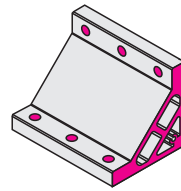

Both sides and screw holes of NBLUT8 is not anodized.

Part Number	Mass (g)	Applicable Screw, T Nut		Allowable Load (N)	Unit Price (1-99 pc(s))	Volume Discount Rate (100-200)
		Screw	T Nut			
NBLUT8	564	CBM8-25	6 HNTT8-8	6	5292	
HBLUT8						



Example

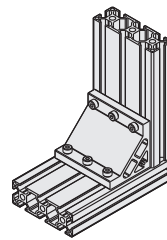

■ **Features:** Brackets to connect Extrusions with 4 slots (HFS8-40160 etc.) with one bracket.

Brackets for Heavy Load

NBLUQ8
HBLUQ8

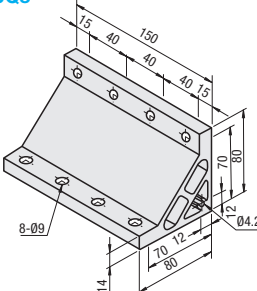

Type	Material	Surface Treatment
NBLUQ8	A6063S-T5	Anodize
HBLUQ8	A6N01SS-T5	Anodize

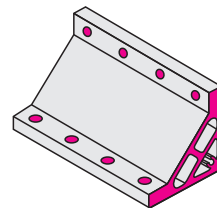

Both sides and screw holes of NBLUQ8 is not anodized.

Part Number	Mass (g)	Applicable Screw, T Nut		Allowable Load (N)	Unit Price (1-99 pc(s))	Volume Discount Rate (100-200)
		Screw	T Nut			
NBLUQ8	770	CBM8-25	8 HNTT8-8	8	7056	
HBLUQ8						



Example

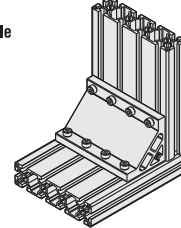

Ordering Example Part Number **HBLUT8**

Alterations Part Number - (C, SET, SST, SEU, SSU, SEP, SSP, SEC) **HBLUT8** - **SET**

Alterations	Code	Spec.	Applicable Bracket
Mounting Hole Alteration for Cover	C	Adds taps on a bracket for cover mounting. (M5 on Both Sides) (Mounting Screw HCBM on P.754)	NBLUT8
			HBLUT8
			NBLUQ8
			HBLUQ8

Alterations	Code	Spec.	Applicable Bracket			
Applicable Screws and Nuts Set	SET	Applicable screws and nuts for fixing the brackets on extrusions come in a set. (Adds to the bracket price.) (Ex.) When HBLUT8 is specified:	NBLUT8			
	SST					
	SEU		Code	Screw	Nut	
	SSU		SET	CBM8-25	HNTT8-8	HBLUT8
	SST		SCB8-25	HNTT8-8		
	SEP		SEU	CBM8-25	HNTU8-8	NBLUQ8
	SSU		SCB8-25	HNTU8-8		
	SSP		SEP	CBM8-25	HNTP8-8	HBLUQ8
	SSP		SCB8-25	HNTP8-8		
	SEC		SEC	HCBST8-29	HNTT8-8	HBLUQ8

Included Screw is not RoHS compliant when -SET, -SEU or -SEP are specified.

Post-Assembly Insertion Easy Brackets

For 8 Series (Slot Width 10mm) Aluminum Extrusions

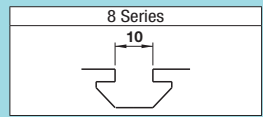

■ **Features:** 2 aluminum extrusions can be easily connected with only 1 tightening screw. Brackets can be mounted on the extrusion slots after assembly.

Post-Assembly Insertion Easy Brackets

Components	Material	Surface Treatment
① Joint Plate	SPCC	
② Joint Brackets	S45C Equivalent	Trivalent Chromate
③ Hex Socket Head Cap Screw	SCM435	



HABL8 ① Joint Plate

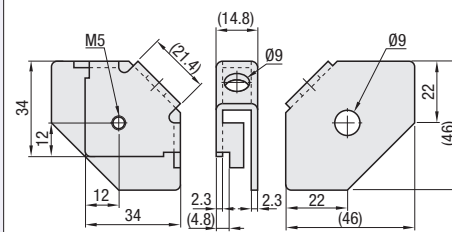

② Joint Brackets

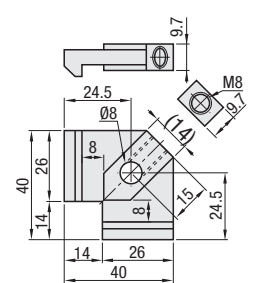

③ Hex Socket Head Cap Screw

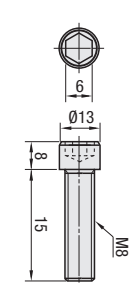

Overtightening may cause deformation of joint plates. (Reference Tightening Torque 15N·m)

Part Number	Mass (g)	Included Screw		Allowable Load (N)	Unit Price (1-99 pc(s))	Volume Discount Rate (100-200)
		Screw	Quantity			
HABL8	120	Hex Socket Head Cap Screw M8x15	1	800		



Example

Ordering Example Part Number **HABL8**



Example

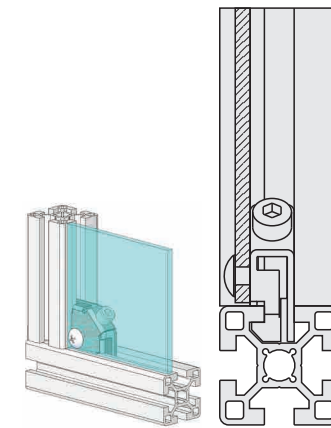

Holes are tapped on a bracket for cover mounting.

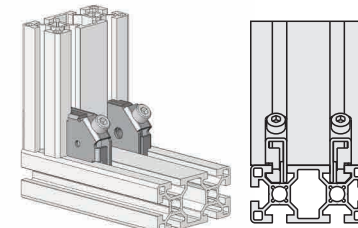

For aluminum extrusions with 2 slots, brackets can be mounted on both sides.

Connection Method

Step Front View Side View Sketch Drawing

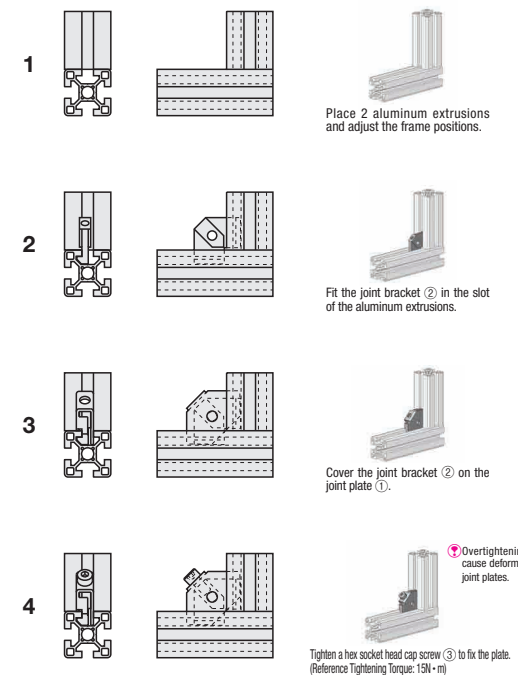

Overtightening may cause deformation of joint plates.

Tighten a hex socket head cap screw ③ to fix the plate. (Reference Tightening Torque: 15N·m)