

MechaLock

Overview

Selection Guidance

Series	Nut	Thin	Standard	Straight Straight for High Torque	Compact
Allowable Load	○	△	○	◎	△
Installation Tool	Wrench	Hex Wrench	Hex Wrench	Hex Wrench	Hex Wrench
Centering Function	Not Provided	Not Provided	Provided	Not Provided	Provided
Features	Installation can be completed by tightening one nut.	The screw is installed directly on the hub. Small difference between the I.D. and O.D.	Available in wide range of sizes, materials and surface treatment types. Centering Function provided	High load capacity Multiple piece can be used easily.	Small difference between the I.D. and O.D. Centering Function provided
Part Number	MLN, MLNB, MLNP	MLSL	MLM, MLMB, MLMP, MLHS	MLA, MLAP, MLAT	MLR, MLRP, MLRS
Page	P.1490	P.1490	P.1491, 1492	P.1493, 1494	P.1495, 1496

Step ① Check Shaft O.D. / Hub I.D.

Select the proper MechaLock based on the shaft O.D. and hub I.D.

See the diagram on the right.

Shaft Outer Dia. ds = MechaLock Inner Dia. d

Hub Inner Dia. Dh = MechaLock Outer Dia. D

Furthermore, make sure that, on the mounting surface of shaft/hub, the value for the tolerance / roughness of surface conforms to the following standards. Otherwise, MechaLock might be unable to be installed.

Mounting Surface	Tolerance	Roughness of Surface
Shaft Outer Dia. ds	h7(g6)	Ra1.6 or less
Hub Inner Dia. Dh	H7	Ra3.2 or less

Step ② Check Installation Space

When installing MechaLock, use a torque wrench.

When installing MechaLock, consider the corresponding installation space.



The photo above shows MLM40.

Ex: Standard

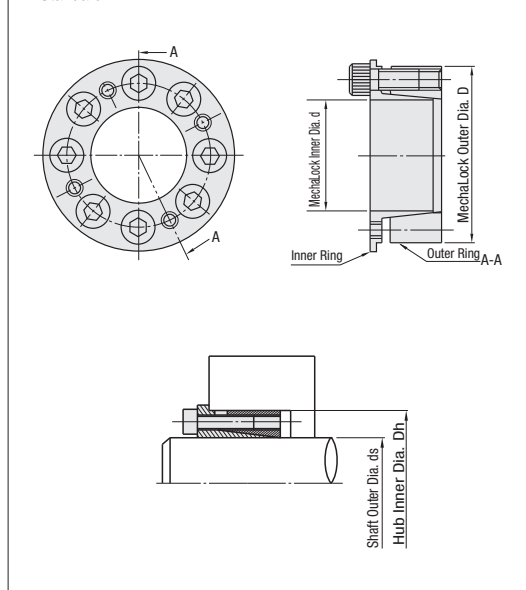

Step ③ Check the Material / Surface Treatment

For MISUMI MechaLock product lineup, a various options are offered in material and surface treatment. For location full of humidity, condensation or moisture, adoption of Electroless Nickel Plating Type or Stainless Steel Type is recommended. It should be noted that the option list for material / surface treatment differs depending on the current series.

Step ④ Check MechaLock for allowable load applied

Calculate the torque/load applied to MechaLock and make sure that the calculation result does not exceed the upper limit provided for the selected series type.

Torque applied to MechaLock < Upper Limit for Torque applied to MechaLock

Thrust Load applied to MechaLock < Upper Limit for Thrust Load applied to MechaLock

Cautions Can be used on shafts/hubs with keyways with width within JIS standards but allowable torque and thrust ratings will be reduced by 15~20%.

Basically, MechaLock must not be subjected to bending moment. The adequate MechaLock becomes available by changing the load receiving location or by selecting the properly shaped hub.

Step ⑤ Check Shaft / Hub for Rigidity

Shaft For shaft materials, verify the Yield Point Stress and select the material that is equal to or exceeds the following value: Side Surface Pressure of Hub provided for the selected series type x 1.2.

Hub For hub materials, verify the Yield Point Stress and select the material that is equal to or exceeds the following value: Side Surface Pressure of Hub provided for the selected series type x 1.2.

For the typical materials used for hub, the corresponding min. outer diameters of hub are calculated and listed. Please refer to the Min. Outer Diameter table for the selected series type.

Cautions

① Tapered portions of inner ring and outer ring will bite into each other even with a little shock from conveyance. Loosen the screw and nut and disassemble parts to release tapered parts before installation.

② Please do not tighten the screw before inserting the shaft. MechaLock may deform.

③ Do not use lock screws other than those included.

MechaLock

Easy Mounting (Nut) / Thin

Feature: Installation can be completed easily just by tightening one nut.

Easy Mounting (Nut)

MLN (Black Oxide)
MLNB (Electroless Nickel Plating)

Type	Material	Surface Treatment
MLN	S45C	-
MLNB		Black Oxide
MLNP		Electroless Nickel Plating

RoHS

Nut of MLNP is colored with RED coating material.

Part Number	Type	d	D	B	D1	L1	L2	L3	L4	Max. Allowable Torque (N·m)	Allowable Thrust Load (kN)	Tightening Torque (N·m)	Mass (g)	Side Surface Pressure of Hub (MPa)	H Hub Minimum O.D. Yield Point Stress of Hub Material (MPa)					Hub Machining Depth L	Unit Price					
															206	294	392	FC350, S3400, S10C	FCD450, S35C		FCD600, S55C	MLN	MLNB	MLNP		
8	14	22	23.5	19	11	8	19	29.4	21	6.9	5.2	24.5	34	178	128	31	24	24	21	22	19	13				
10	17		21	12	9	21	34.3	24			4.8	29.4	43	128	89	33	28	26	23	24	21	14				
11	18	24	26					22	39.2	28	5.1	34.3	46	132	92	38	30	29	25	25	23					
12	20		23	13				23	49.0	34	7.3	5.7	44.1	50	122	82	40	32	31	27	28	25	15			
14	23		26	15				26	88.3	62	12.3	8.9	58.8	80			41	34	34	30	31	28	17			
15	24	30	32.5	27	16			27	108	76	13.7	10.1	68.6	85	106	73	43	36	35	31	32	29	18			
17	26		31	19				31	186	130	19.6	15.3	98.1	96	107	74	50	41	40	35	36	33	21			
20	29		33	20				33	245	172	24.5	17.2	137	135	114	80	52	44		39	40	37	22			
22	32	36	35	22				35	275	193		17.6	147	147	90	62	54	46	45	41	41	38	24			
24	34		37	24				37	314	220	25.5	18.3	167	185	83	58			48	47	42	43	20			
25	35	41	38	25				38	353	247	27.5	19.8	186	187	85.1	60	55		49	48	44	44	21			
28	40	50	54	43	28	15	43	378	265	26.5	18.9	226	320	68.9	48	57	52	51	48	48	45	30				
30	42	55	60	46	30	16	46	392	274		18.3	255	398	66.3	46	61	55	54	50	50	48	32				
35	48	60	66	52	35	17	52	461	323		18.5	294	521	50	35	64	59	58	55	55	53	37				

Ordering Example Part Number MLN25

Recommended Tolerance of Shaft and Hub / Roughness of Surface

Shaft O.D.	h7(g6)	Ra1.6 or less
Hub I.D.	H7	Ra3.2 or less

How to Determine Hub O.D.

After selecting the MechaLock size, hub size and material, confirm that the selected values meet the conditions Hshub in the Minimum O.D. Table.

kgf= Nx0.101972 kgf/mm²= MPax0.101972

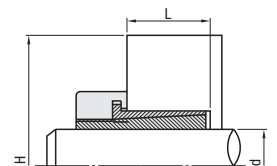

Features: Because the screw is installed directly on the hub, the inner and outer diameter difference is small and thin. Applicable to installation on a small hub.

Thin

MLSL

Type	Material	Surface Treatment
MLSL	S45C	-

RoHS

Part Number	Type	d	D	D1	P.C.D.	T	B	Locking Screw		Max. Allowable Torque (N·m)	Allowable Thrust Load (kN)	Mass (g)	Side Surface Pressure of Hub (MPa)	H Hub Minimum O.D. Yield Point Stress of Hub Material (MPa)					Hub Machining Depth L1	Unit Price									
								MxL	Qty.					206	294	392	FC350, S3400, S10C	FCD450, S35C			FCD600, S55C								
5	8	22	15					M3x10	3	4	2	13	134	21.5	21.5	21.5													
6	9	23	16			4	10	M3x10	3	6	2	15	132	23	22.5	22.5						8							
8	11	25	18					M3x10	3	9	2	17	123	25	24.5	24.5													
10	13	29	21			5	12	M3x10	3	18	4	28	153	38	29	29						9.5							
12	15	31	23					M3x10	3	23	4	31	139	39	31	31													
14	18	36	26					M3x10	3	37	5	52	161	56	38	36													
15	19	37	27					M4x18	4	39	5	55	149	52	38	37													
16	20	38	28			6	14	M4x18	4	42	5	57	143	52	39	38						11							
17	21	39	29					M4x18	4	45	5	59	138	52	39	39													
19	24	42	32					M4x18	4	49	5	71	118	51	42	42													
20	25	46	36					M5x20	4	97	10	103	198		62	49													
22	26	47	37					M5x20	4	110	10	101	196		64	51													
24	28	49	39					M5x20	4	121	10	106	184		64	52													
25	30	51	41			7	15	M5x20	4	124	10	119	169		101	63	53												
28	32	53	43					M5x20	4	141	10	118	160		96	64	55												
30	35	56	46					M5x20	4	149	10	135	145		89	66	57												

* Unavailable due to excessive Side Surface Pressure

Ordering Example Part Number MLSL10

How to Determine Hub O.D.

After selecting the MechaLock size, hub size and material, confirm that the selected values meet the conditions Hshub in the right-hand Hub Minimum O.D. Table.

Recommended Tolerance of Shaft and Hub / Roughness of Surface

Shaft O.D.	h7(g6)	Ra1.6 or less
Hub I.D.	H7	Ra3.2 or less

