



Timing Belt Conveyor GV Series

Dual Track, Head Drive, 2-Groove Frame (Pulley Dia. 30 mm)

Conveyor Resource Site:
<http://www.misumiusa.com/conveyor/>
 The above site can be used to search for conveyor components and their maintenance parts.

Features: Has a construction that allows for easy belt replacement in comparison to CVG7A. Available with the motor and pulley holders positioned either inboard or outboard. Head drive timing belt conveyor ideal for conveying objects on pallets, or for incorporating inside of equipment.

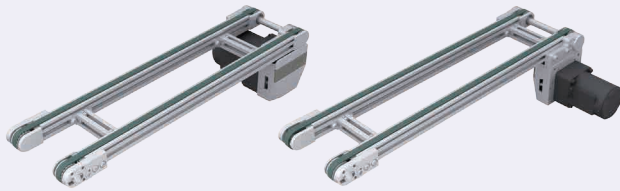

*Taiwanese Motors are not RoHS compliant.

6 W Motor Type

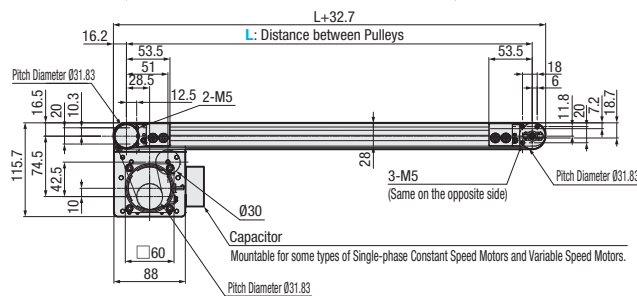
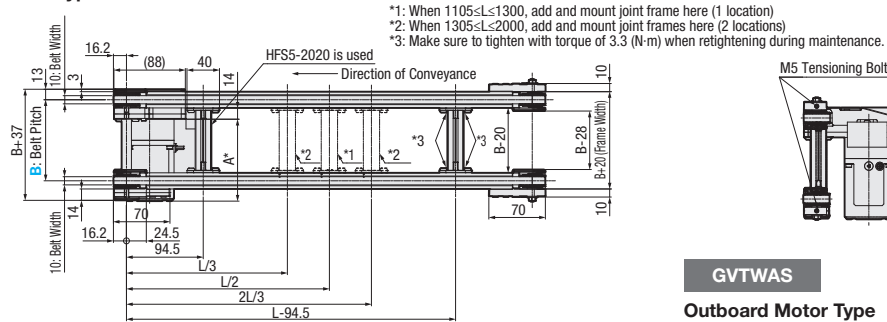

25 W Motor Type

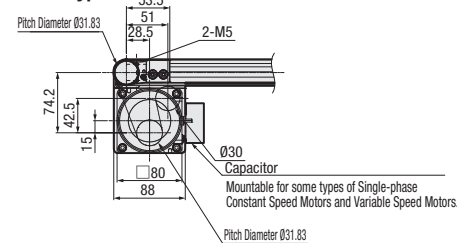

GVTWU (Inboard Motor Type)/ GVTWAS (Outboard Motor Type)

- Each slot has 4 nuts inserted.
- The lengths of the conveyor belts on either sides of this product are different.
- Please take care when removing the plastic cover, as it is relatively fragile.
- When $L > 1,400$, it is recommended to mount on at least 2 stands.

	Frame	Motor Cover	Pulley Holder
M Material	Aluminum	Aluminum	Aluminum
S Surface Treatment	Clear Anodize	Painted	Painted

GVTWAS Outboard Motor Type

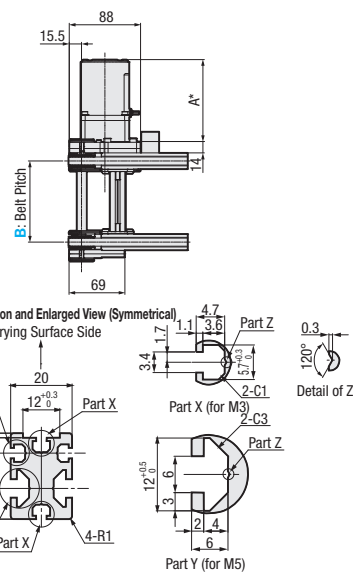

*A Dimension Details

Output (W)	Motor Specifications	Manufacturer	Reduction Ratio	A
6 W	Constant speed motor	Oriental	25-180	115.0
		Taiwanese	25-75	114.7
		Oriental	90-180	120.7
	Variable speed motor	Oriental	25-180	125.0
		Taiwanese	25-75	126.9
		Taiwanese	90-180	132.9
25 W	Constant speed motor	Panasonic	5-180	115.0
		Oriental	5-18	117.0
		Taiwanese	25-180	127.5
	Variable speed motor	Oriental	5-75	129.0
		Taiwanese	90-180	136.0
		Taiwanese	5-18	127.0
	Variable speed motor	Oriental	25-180	137.5
		Taiwanese	5-75	139.5
		Taiwanese	90-180	146.5

Conveying Capacity

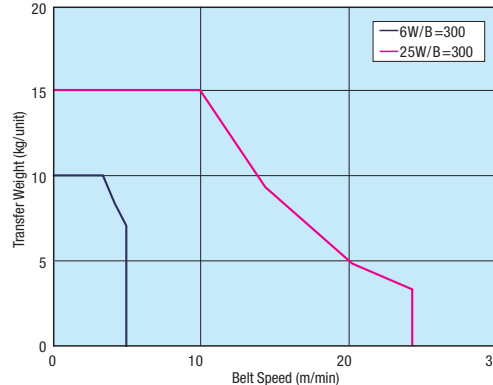

- For accumulation conveyance (only compatible with sliding belts), consider conveying capacity to be no more than 1/2 of that shown in the graph.
- Conveying capacity may vary depending on operating conditions.
- This graph shows conveying capacity when level.

Gearhead Reduction Ratio

*Reference Value
 *Conveyance speed reference values are based on IM (motor rotational speed 1,500 rpm [50 Hz]/1,800 rpm [60 Hz]).
 *May decrease depending on load condition.

Gearhead Reduction Ratio	Belt Speed (m/min)	
	50Hz	60Hz
5	30.0	36.0
7.5	20.0	24.0
9	16.7	20.0
12.5	12.0	14.4
15	10.0	12.0
18	8.3	10.0
25	6.0	7.2
30	5.0	6.0
36	4.2	5.0
50	3.0	3.6
60	2.5	3.0
75	2.0	2.4
90	1.7	2.0
100	1.5	1.8
120	1.2	1.5
150	1.0	1.2
180	0.8	1.0

- For motor specification IM, the above conveyance speeds are constant speeds.
- For motor specification SCM, refer to the above values for the maximum speed.
- Motor specification SCM is adjustable up to $(1/15) \times (\text{max. speed})$. The weight that can be conveyed decreases as speed decreases.

Part Number	B 10 mm Increments	L 5 mm Increments	Motor				Belt Specifications	Motor Manufacturer Selection
			Output (W)	Voltage (V)	Specifications	Gearhead Reduction Ratio		
GVTWU (Inboard Motor Type)	50~300	250~2000	6	TA110 TA115 TA220 TA230 (Single-phase)	IM (Constant Speed Motor) SCM (Variable Speed Motor)	25 30 36 50 60 75 90 100 120 150 180	H (General Purpose, Translucent) S (For Sliding, Green) J (No Belt)	B (Oriental Motor) C (Taiwanese Motor) *For C, the conveyance speed may decrease by approx. 20%. A (Panasonic Motor) B (Oriental Motor) C (Taiwanese Motor) *SCM (Variable Speed Motor) is not selectable for A. *For C, the conveyance speed may decrease by approx. 20%. R (No Motor, Gearhead)
			25	TA110 TA115 TA220 TA230 (Single-phase)	IM (Constant Speed Motor) SCM (Variable Speed Motor)	5 7.5 9 12.5 15 18 25 30 36 50 60 75 90 100 120 150 180		
			6 25	SA220 SA230 (3-Phase)	IM (Constant Speed Motor)			
GVTWAS (Outboard Motor Type)				NV (No Motor)	NM (No Motor)	NH (No Gearhead)		

- Connect the motor so that the belt rotates in the direction of conveyance.
- When "No motor, gearhead" is selected, the motor mounting hole pitch will vary depending on the motor output. For the dimension details, see Technical Information in our Conveyor Selection web site.
- When "No motor, gearhead" is selected, this unit will be delivered unassembled. The customer is to assemble the unit by following instructions on the included assembly procedure manual. See our Conveyor Selection site for packaging details.
- Mounting brackets for speed controllers are not included with the variable speed motor. When mounting brackets for speed controllers are required, select [SCB] as an alteration.
- Regardless of belt specifications, it is not recommended to use the belt while the conveyor is tilted.

Part Number	B	Available Sizes																		
		L250-300	L305-400	L405-500	L505-600	L605-700	L705-800	L805-900	L905-1000	L1005-1100	L1105-1200	L1205-1300	L1305-1400	L1405-1500	L1505-1600	L1605-1700	L1705-1800	L1805-1900	L1905-2000	
GVTWU GVTWAS	50-100	○	○	○	○	○	○	○	○	○	○	○	○	○	○	○	○	○	○	○
	110-150	○	○	○	○	○	○	○	○	○	○	○	○	○	○	○	○	○	○	○
	160-200	○	○	○	○	○	○	○	○	○	○	○	○	○	○	○	○	○	○	○
	210-250	○	○	○	○	○	○	○	○	○	○	○	○	○	○	○	○	○	○	○
	260-300	○	○	○	○	○	○	○	○	○	○	○	○	○	○	○	○	○	○	○

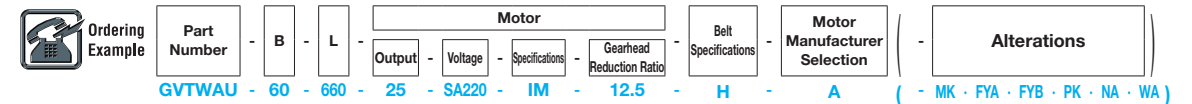

Days to Ship [Configure Online](#)

- Alterations
- Motor Position Reversed
 - Additional Counterbores
 - Brackets for Speed Controller Included
 - Stands (Legs)
 - Pulley Holder Reversed

Conveyor weight
 *Reference values (vary depending on motor manufacturer) (kg)

Belt width B (mm)	Conveyor length L (mm)			
	500	1000	1500	2000
100	3.4	4.4	5.4	6.3
200	3.6	4.6	5.6	6.6
300	3.9	4.9	5.9	6.8

*When the motor output is 25 W, add 1.5 kg.