

# Casters & Adjustment Pads Assembly

-Custom Mounting Hole Type-

# Allowable Load: 588~4902N

CAD Data Folder Name: Casters

\* All prices are in \$ and subjected to change without prior notice

**RoHS**

Part Number	Wheel	No.	Main Body	Jack Bolt	Pad
Type	(M) (Color)	(M)	(S)	(M)	(S)
60	Nylon (Gray)	60	ADC12 Black Painting	SS400	Trivalent Chromate
130	Urethane (Green)	130	SPHC Trivalent Chromate (Black)	SS400	Trivalent Chromate
250	MC Nylon (Blue)	250	SPHC Trivalent Chromate (Black)	SS400	Trivalent Chromate
350	Conductive MC Nylon (Black)	350	SPHC Trivalent Chromate (Black)	SS400	Trivalent Chromate
500	MC Nylon (Black)	500	FCD45 Black Painting	SS400	Trivalent Chromate

†HCFTF500 is phenol (black).  
†HCFTFD250 and 350 is gray.  
‡For No.500 type, pad is not attached.

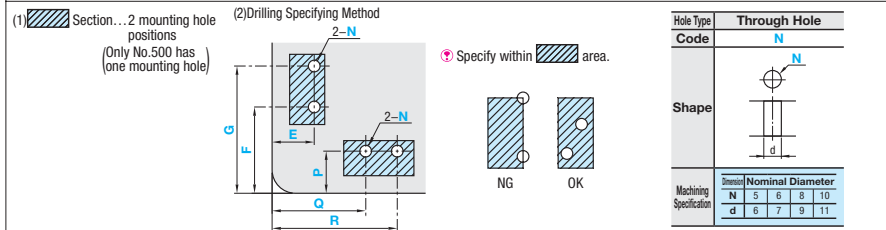
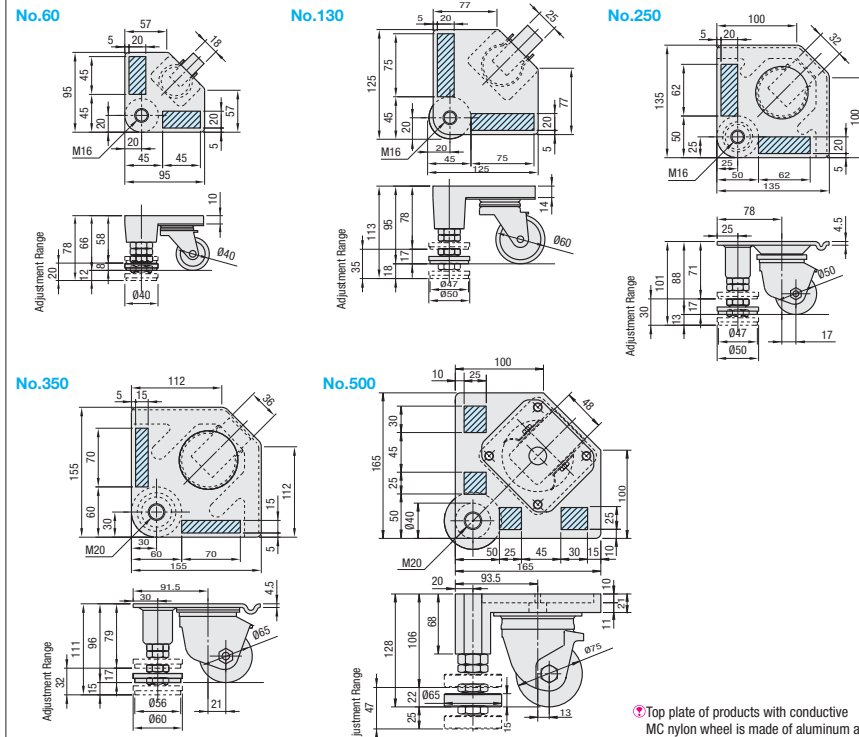

Part Number	N (Nominal Diameter) Selection	Drilling Position		1mm Increment		Allowable Load		Mass g
		E - P	F · G · Q · R	kgf	N			
HCFTF	60	5	6	(45+N/2)-(90-N/2)	60	588	600	
HCFTF HCFTFU HCFTFD	130	6	8 10	(5+N/2)-(25-N/2)	130	1275	1100	
HCFTF HCFTFU HCFTFM HCFTFD	250	6	8 10	(50+N/2)-(112-N/2)	250	2451	1445	
HCFTF HCFTFU HCFTFM HCFTFD	350	6	8 10	(5+N/2)-(20-N/2)	350	3432	2170	
HCFTF HCFTFU HCFTFM HCFTFD	500	8	10	(10+N/2)-(35-N/2)	500	4902	5600	

Order Example: Part Number - N - E - F - G - P - Q - R  
 HCFTF130 - 6 - E18 - F55 - G80 - P20 - Q55 - R70

Days to Ship: 7 Days

No.	Unit Price							
	HCFTF		HCFTFU		HCFTFM		HCFTFD	
	Qty. 1-9	Qty. 10-20	Qty. 1-9	Qty. 10-20	Qty. 1-9	Qty. 10-20	Qty. 1-9	Qty. 10-20
60	69.95	66.42	-	-	-	-	-	-
130	88.24	83.75	-	-	123.86	117.60	140.06	133.00
250	138.62	131.72	180.17	171.03	181.62	172.47	186.75	177.29
350	160.60	152.58	201.51	191.40	205.84	195.42	210.98	200.39
500	356.82	339.01	-	-	446.83	424.36	479.07	455.01

Alterations: Part Number - N - E - F - G - P - Q - R - (BL)  
 HCFTF130 - 6 - E18 - F55 - G80 - P20 - Q80 - R70 - BL150

\*For orders larger than indicated values, please request for quotation.

Alteration	Adjustment Pad Length								
	BL100				BL150				
Code	Type	No.	Height from Floor Standard	Price Adder	Type	No.	Height from Floor Standard	Price Adder	
Spec.	HCFTF HCFTFU HCFTFM HCFTFD	60	78	132	5.45	60	78	178	6.42
		130	113	152		130	113	200	
		250	101	145		250	101	191	
		350	111	150		350	111	200	
		500	-	-		500	150	210	
		500	-	-		-	500	150	

\*The height from the floor can be increased by using a longer adjusting pad. However, the adjustment pad sticks out from the plate surface.

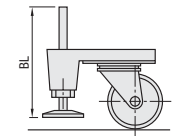

ex Example

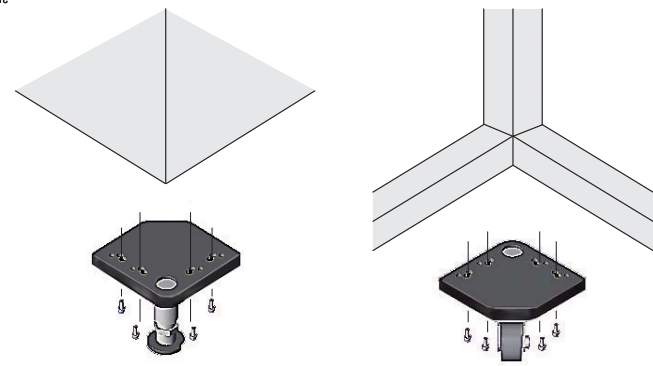

Specify mounting hole position in accordance with frame size. For the types of aluminum frames, refer to P.2291.