

QUICK-FITTING JOINTS FOR MOLD COOLING

Green character items
now kept in stock.

 Stock Items in Thailand



C-M-PC (Straight hexagon shoulder joint)

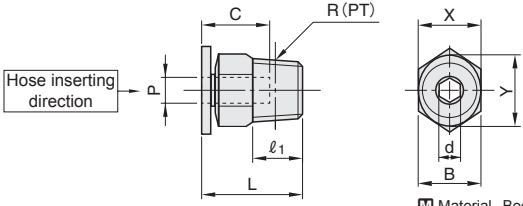

Material Body: brass
Open ring: resin
※ Leakproof material is applied to the thread part.

Applicable Hose Outer Diameter*Inner Diameter	Hose Inserting Hole		Hexagon Socket Hole ○ d	L	B	l ₁	X	Y	R (PT)	Model		U/price	
	Hole Diameter	Depth								Type	No.		
4M 2.5	4	15	○ 3	20.5	10	8	10	12	1/8	C-M-PC	4-01	Quotation via WOS	
				19	19	10			1/4		4-02		
6M 4	6	15	○ 4	21	12	8	12	14	1/8		6-01		
				23	14	10			1/4		6-02		
				21	17	11			3/8		6-03		
8M 6	8	18	○ 5	26	14	8	14	16	1/8		8-01		
				25		10			1/4		8-02		
				22		11			3/8		8-03		
10M 8	10	22	○ 5	17	8	17	19	1/8	10-01				
			○ 6					31.5	10		1/4		10-02
			○ 8					29	11		3/8		10-03
12M10	12	22	○ 6	21	10	21	23	1/4	12-02				
			○ 8					31.1	11	3/8	12-03		

⚠ Please keep the shock pressure (transient pressure caused by shock waves) under the maximum operating pressure (300kPa) when it is in use.



C-M-POC (Straight hexagon socket joint)

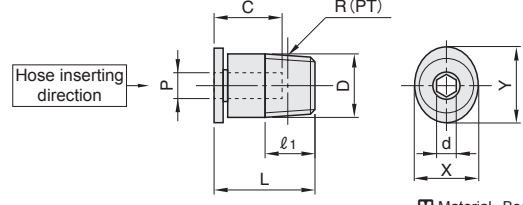

Material Body: brass
Open ring: resin
※ Leakproof material is applied to the thread part.

Applicable Hose Outer Diameter*Inner Diameter	Hose Inserting Hole		D	Hexagon Socket Hole ○ d	L	l ₁	X	Y	R (PT)	Model		U/price	
	Hole Diameter	Depth								Type	No.		
4M 2.5	4	15	10	○ 3	20.5	8	10	12	1/8	C-M-POC	4-01	Quotation via WOS	
			12		21						10		1/4
6M 4	6	15	14	○ 4	23	10	12	14	1/4		6-02		
					26				8		1/8		8-01
					25				10		1/4		8-02
8M 6	8	18	17	○ 5	22	11	14	16	3/8		8-03		
					29				10		1/4		10-02
					29				11		3/8		10-03
12M10	12	22	21	○ 8	31	11	21	23	3/8		12-03		

⚠ Please keep the shock pressure (transient pressure caused by shock waves) under the maximum operating pressure (300kPa) when it is in use.

 **Order** **Part Number**
C-M-POC 6-02

 **Delivery**  **1** Day

 **Price** **Contact Information for Inquiry**
WOS: <http://th.misumi-ec.com/>
TEL: 038-959-200 FAX: 038-959-202

Quantity discount rate

Quantity	1~19	20~99	100~199	≥200
Rate	-	5%	10%	15%

⚠ To be quoted on price & lead time above Max. Q'ty

QUICK-FITTING JOINTS FOR MOLD COOLING

Green character items now kept in stock.

 Stock Items in Thailand



C-M-PL (L-shaped hexagon shoulder joint)

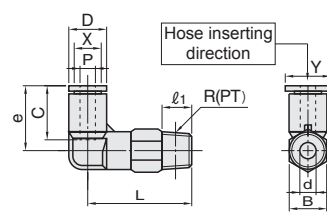

Material Body: resin
Open ring: resin
Thread part: brass
※ Leakproof material is applied to the thread part.

Applicable Hose Outer Diameter*Inner Diameter	Hose Inserting Hole		D	d	L	e	B	l ₁	X	Y	R (PT)	Model		U/price
	Hole Diameter	Depth										Type	No.	
4M 2.5	4	15	11	2.6	30	23.5	10	8	10	12	1/8	C-M-PL	4-01	Quotation via WOS
					33		14	10			1/4		4-02	
6M 4	6	15	13	4.6	31.5	24	12	8	12	14	1/8		6-01	
					34	24.5	14	10			1/4		6-02	
					35	24	17	11			3/8		6-03	
8M 6	8	18	14.4	5	35	29	14	8	14	16	1/8		8-01	
					37		10	14			1/4		8-02	
					38.5		11	16			3/8		8-03	
10M 8	10	22	18.4	5	42	36.5	17	8	17	19	1/8		10-01	
					44			10			17		1/4	
					45			11			19	3/8	10-03	
12M10	12	22	21	8	46.5	39	17	10	21	23	1/4	12-02		
				9	47.5		11	19			3/8	12-03		

⚠ Please keep the shock pressure (transient pressure caused by shock waves) under the maximum operating pressure (300kPa) when it is in use.



C-M-POL (L-shaped hexagon socket joint)

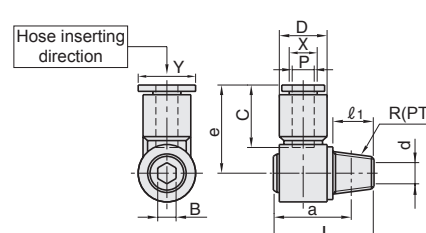

Material Body: resin
Open ring: resin
Thread part: brass
※ Leakproof material is applied to the thread part.

Applicable Hose Outer Diameter*Inner Diameter	Hose Inserting Hole		Hexagon socket spanner dimension \varnothing B	D	d	L	e	l ₁	X	Y	R (PT)	Model		U/price	
	Hole Diameter	Depth										Type	No.		
6M4	6	15	\varnothing 6	13	5	22.6	30	8	12	14	1/8	C-M-POL	6-01	Quotation via WOS	
			\varnothing 8				25.1	34			10		1/4		6-02
8M6	8	18	\varnothing 6	14.4	7	22.6	32	8	14	16	1/8		8-01		
			\varnothing 8				25.1	37			10		1/4		8-02
			\varnothing 10				30.4	40			11		3/8		8-03
10M8	10	22	\varnothing 8	18.4	8	25.1	41	10	17	19	1/4		10-02		
			\varnothing 10				30.4	42			11		3/8		10-03
12M9	12	22	\varnothing 12	21	10	30.4	46	11	21	23	3/8		12-03		

⚠ Please keep the shock pressure (transient pressure caused by shock waves) under the maximum operating pressure (300kPa) when it is in use.



Order

Part Number
C-M-POL 6-02



Delivery

 **1** Day



Price

Contact Information for Inquiry
WOS: <http://th.misumi-ec.com/>
TEL: 038-959-200 FAX: 038-959-202

Quantity discount rate

Quantity	1~19	20~99	100~199	≥200
Rate	-	5%	10%	15%

⚠ To be quoted on price & lead time above Max. Q'ty



QUICK-FITTING JOINTS FOR MOLD COOLING

Green character items
now kept in stock.

Stock Items in Thailand

10 PACK-C-M-PC (For 10 pcs) (Straight hexagon shoulder joint)

Material Body: brass
Open ring: resin
※ Leakproof material is applied to the thread part.

Applicable Hose Outer Diameter*Inner Diameter	Hose Inserting Hole		Hexagon Socket Hole ○ d	L	B	l ₁	X	Y	R (PT)	Model		U/price		
	Hole Diameter	Depth								Type	No.			
4M 2.5	4	15	○ 3	20.5	10	8	10	12	1/8	10 PACK-C-M-PC	4-01	Quotation via WOS		
				19	19	10					4-02			
6M 4	6	15	○ 4	21	12	8	12	14	1/8		6-01			
				23	14	10					6-02			
				21	17	11					6-03			
8M 6	8	18	○ 5	26	14	8	14	16	1/8		8-01			
				25		10					14		8-02	
				22		11					3/8		8-03	
10M 8	10	22	○ 5	17	8	17	19	1/8	10-01					
			○ 6						31.5		10		1/4	10-02
			○ 8						29		11		3/8	10-03
12M10	12	22	○ 6	21	10	21	23	1/4	12-02					
			○ 8						31.1	11	3/8	12-03		

※ Please keep the shock pressure (transient pressure caused by shock waves) under the maximum operating pressure (300kPa) when it is in use.

10 PACK-C-M-POC (For 10 pcs) (Straight hexagon socket joint)

Material Body: brass
Open ring: resin
※ Leakproof material is applied to the thread part.

Applicable Hose Outer Diameter*Inner Diameter	Hose Inserting Hole		D	Hexagon Socket Hole ○ d	L	l ₁	X	Y	R (PT)	Model		U/price					
	Hole Diameter	Depth								Type	No.						
4M 2.5	4	15	10	○ 3	20.5	8	10	12	1/8	10 PACK-C-M-POC	4-01	Quotation via WOS					
			12		21						10		12	14	1/4	6-02	
6M 4	6	15	14	○ 4	23	10	14	16	1/8		8-01						
					26						8		1/4	8-02			
					25						10		14	16	3/8	8-03	
8M 6	8	18	17	○ 5	22	11	17	19	1/4		10-02						
					○ 6						31.5		10	17	19	1/4	10-03
					○ 8						29		11	21	23	3/8	12-03
12M10	12	22	21	○ 8	31	11	21	23	3/8		12-03						

※ Please keep the shock pressure (transient pressure caused by shock waves) under the maximum operating pressure (300kPa) when it is in use.



Part Number
10 PACK-C-M-PC6-02
10 PACK-C-M-POC8-02



Delivery **1** Day



Price
Contact Information for Inquiry
WOS: <http://th.misumi-ec.com/>
TEL: 038-959-200 FAX: 038-959-202



QUICK-FITTING JOINTS FOR MOLD COOLING

Green character items
now kept in stock.

Stock Items in Thailand



10 PACK-C-M-PL (For 10 pcs) (L-shaped hexagon shoulder joint)

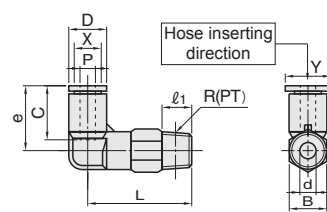

M Material Body: resin
Open ring: resin
Thread part: brass
※ Leakproof material is applied to the thread part.

Applicable Hose Outer Diameter/Inner Diameter	Hose Inserting Hole		D	d	L	e	B	l ₁	X	Y	R (PT)	Model		U/price		
	Hole Diameter	Depth										Type	No.			
4M 2.5	4	15	11	2.6	30	23.5	10	8	10	12	1/8	10 PACK-C-M-PL	4-01	Quotation via WOS		
							14	10					4-02			
6M 4	6	15	13	4.6	31.5	24	12	8	12	14	1/8		6-01			
					34	24.5	14	10					6-02			
					35	24	17	11					6-03			
8M 6	8	18	14.4	5	35	29	14	8	10	14	16		1/8		8-01	
					37		10	11							3/8	8-02
					38.5		11	8							1/8	8-03
10M 8	10	22	18.4	5	42	36.5	17	8	17	19	1/4		10-01			
					44		10	11							3/8	10-02
					45		11	8				1/8		10-03		
12M10	12	22	21	8	46.5	39	17	10	21	23	1/4	12-02				
					9		47.5	11					3/8	12-03		

Please keep the shock pressure (transient pressure caused by shock waves) under the maximum operating pressure (300kPa) when it is in use.



10 PACK-C-M-POL (For 10 pcs) (L-shaped hexagon socket joint)

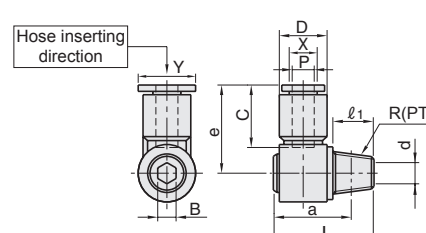

M Material Body: resin
Open ring: resin
Thread part: brass
※ Leakproof material is applied to the thread part.

Applicable Hose Outer Diameter/Inner Diameter	Hose Inserting Hole		Hexagon socket spanner dimension \bigcirc B	D	d	L	e	l ₁	X	Y	R (PT)	Model		U/price
	Hole Diameter	Depth										Type	No.	
6M4	6	15	\bigcirc 6	13	5	22.6	30	8	12	14	1/8	10 PACK-C-M-POL	6-01	Quotation via WOS
			\bigcirc 8				25.1	34					10	
8M6	8	18	\bigcirc 6	14.4	7	22.6	32	8	14	16	1/8		8-01	
			\bigcirc 8			25.1	37	10					8-02	
			\bigcirc 10			30.4	40	11					8-03	
10M8	10	22	\bigcirc 8	18.4	8	25.1	41	10	17	19	1/4		10-02	
			\bigcirc 10			30.4	42	11					10-03	
12M9	12	22	\bigcirc 12	21	10	30.4	46	11	21	23	3/8		12-03	

Please keep the shock pressure (transient pressure caused by shock waves) under the maximum operating pressure (300kPa) when it is in use.



Order

Part Number
10 PACK-C-M-PL6-01
10 PACK-C-M-POL8-02



Delivery

1 Day



Price

Contact Information for Inquiry
WOS: <http://th.misumi-ec.com/>
TEL: 038-959-200 FAX: 038-959-202