

SLIDE LOCK SETS

Green character items
now kept in stock.

 Stock Items in Thailand

C-MPSL

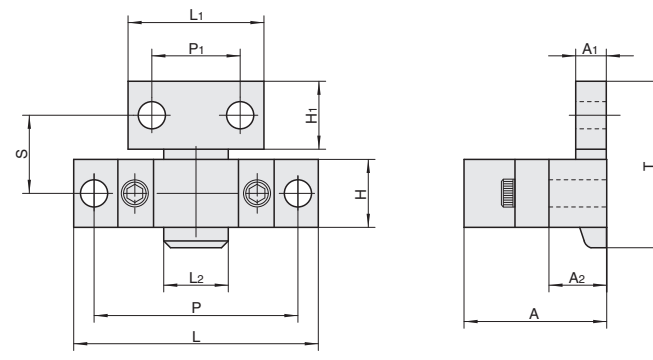



Material: SCM21
CB: 2 pcs.

Model		Max usable load (2 sets under normal temp Reference values)	L1	P1	H1	A1	A2	L2	A	T	L	P	H	S	Bolt Hold	U/price
Type	No.															
C-MPSL	250	2451N {250kg}	40	26	20	9	16.5	19.5	41.5	49	72	60	20	23	M 8	Quotation via WOS
	300	2942N {300kg}	50	30	22	9	16.5	28.4	41.5	73	113	90	30	38	M10	
	400	3922N {400kg}	50	30	22	12	20	29	48	73	113	90	30	38	M12	

 Order **Part Number**
C-MPSL 250

 Delivery  **1** Day

 Price **Contact Information for Inquiry**
WOS: <http://th.misumi-ec.com/>
TEL: 038-959-200 FAX: 038-959-202

Structure and Usage

- Adjust opening/closing load of slide lock sets by Allen wrench. The load is maximum when the adjustment bolt is fully tightened.
- Make sure to assemble this product in pairs to symmetrical positions in mold for well balanced operation.
- Mount it in parallel to the parting line.
-  Tighten fixing screw to prevent component failure caused by screw loosening.

